

FRESHWATER FROM THE SEAS

NUCLEAR DESALINATION PROJECTS ARE MOVING AHEAD

BY T. KONISHI AND B.M.MISRA

Freshwater demand is ever increasing. In its latest projections, the World Water Forum in 2000 particularly focused attention on the increasing needs for freshwater to supply the world's growing cities to the year 2025.

Renewable resources of freshwater amount to about 40,000 cubic kilometers. Of this amount, only 10% is withdrawn and 5% is consumed. The problem is the resources are not evenly distributed geographically and seasonally.

It is becoming increasingly clear that all available and appropriate technologies, including nuclear and related technologies, should be used for the sustainable development and management of freshwater resources. One particular approach is the desalination of seawater, and countries are increasing their capacity to tap the oceans. (*See graph, page 6.*) The energy for these plants is generally supplied in the form of either

steam or electricity. Conventional fossil fuels have normally been used as the primary energy sources. But their intensive use is raising environmental concerns.

The prospects of using nuclear energy for seawater desalination on a large scale are attractive since desalination is an energy intensive process. As such, the heat from a nuclear reactor and/or the electricity produced by such plants can be used at desalination facilities. The successful operation of a sodium-cooled nuclear power plant (BN-350) at Aktau, Kazakhstan has proved the technical feasibility, compliance with safety requirements and reliability of such cogeneration nuclear reactors. Also on a smaller scale, some ten desalination facilities connected to pressurized water reactors (PWRs) have been operated successfully in Japan. Large-scale commercial deployment of nuclear desalination will mainly depend on its economic competitiveness with alternate

energy supply options, and market demand in countries where water and energy needs are most acute.

Through its programmes, the IAEA has brought together experts from different countries to study technical, economic, and other aspects of nuclear desalination.* Activities have included preparation and publication of a technical document, *Options Identification Programme for Demonstration of Nuclear Desalination* (TECDOC-898), and the proceedings of the International Symposium on Nuclear Desalination of Seawater in 1997 (Proceedings Series STI/PUB/1025). The findings added momentum to efforts in many IAEA Member States interested in evaluating, planning or initiating nuclear desalination projects.

All nuclear reactors can provide energy, as required by desalination processes, and could be used for desalination depending on the timeframe of application. Some relevant experience has come from nuclear plants that are used for district heating systems, a topic which the IAEA has reviewed in a technical document

Mr. Konishi is a staff member in the IAEA Division of Nuclear Power, Nuclear Technology Development Section. Mr. Misra is Head of the Desalination Division, Bhabha Atomic Research Centre, India.

**Nuclear desalination is defined to be the production of potable water from seawater in a facility in which a nuclear reactor is used as the source of energy (electrical and/or thermal) for the desalination process. The facility may be dedicated solely to the production of potable water, or may be used for the generation of electricity and the production of potable water; in which case only a portion of the total energy output of the reactor is used for water production. In either case, the notion of nuclear desalination is taken to mean an integrated facility in which both the reactor and the desalination system are located on a common site and energy is produced on-site for use in the desalination system. It also involves at least some degree of common or shared facilities, staff, and structures.*

PROJECTED GROWTH OF DESALINATION PLANT CAPACITY

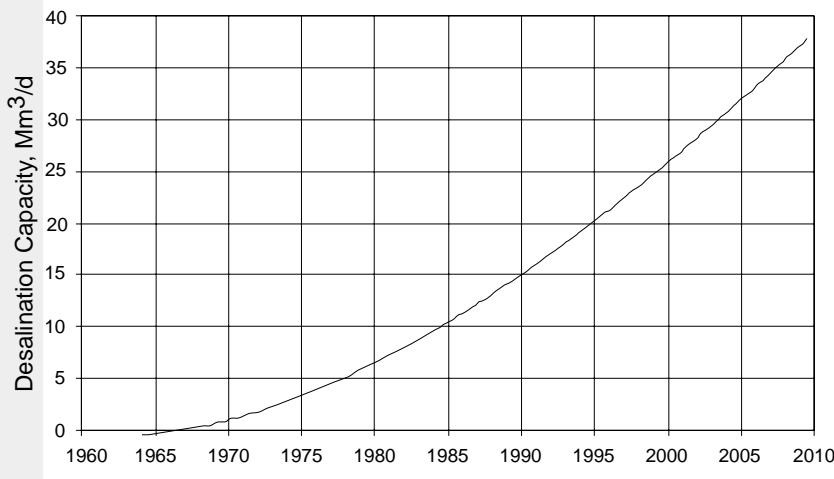

Source: Wangnick, 2000: estimates at on IAEA Consultancy Meeting.
Note: Data include operating and contracted capacity.

(TECDOC-1056). The safety, regulatory and environmental concerns in nuclear desalination are those related directly to nuclear power plants, with due consideration given to the process of coupling the plant to the desalination facility. Existing international safety standards and guides seem to be appropriate in covering such desalination plants.

An IAEA coordinated research project on "Optimization of the Coupling of Nuclear Reactors and Desalination Systems" started in 1998 with participation of research institutes from nine countries. The work covers a review of reactor designs suitable for coupling with desalination systems, the optimization of this coupling, performance improvements, and advanced technologies of desalination systems for nuclear desalination.

Helpful to many countries has been an IAEA software package called "Desalination Economic Evaluation Program",

or DEEP. Its output includes the levelized cost of water and power, a breakdown of cost components, energy consumption and net saleable power for each selected option. Specific power plants can be modelled by adjustment of input data including design power, power cycle parameters and costs.

DEEP serves three objectives. It enables calculation of the levelized cost of electricity and desalted water as a function of quantity, site-specific parameters, energy source and desalination technology. Secondly, it enables side-by-side comparison of a large number of design alternatives on a consistent basis with common assumptions. Thirdly, it enables quick identification of the lowest cost options for providing specified quantities of desalted water and/or power at a given location.

The software has been applied to perform a comprehensive economic

assessment of nuclear seawater desalination in comparison with fossil options. The results -- published in IAEA TECDOC-1186 -- generally show that nuclear desalination can offer potable water at a cost in the same range as fossil options; hence, both options can be seen as viable in many regions.

A new IAEA publication, *Introduction of Nuclear Desalination: A Guidebook* (Technical Report Series STI/DOC/010/400), gives an overview of nuclear desalination. It also identifies special considerations for decision-making, and provides guidance for steps to be taken once a decision has been made on the option of nuclear desalination.

International Collaboration. To facilitate development activities, the IAEA has collected and disseminated relevant information at various technical meetings attended by experts from Member States which are operating, designing, planning, or interested in nuclear desalination.

To add to the operating experience in Japan and Kazakhstan, new nuclear desalination plants are foreseen for demonstration in several countries. The Republic of Korea, for example, has progressed in the design of a cogenerating nuclear desalination plant using a 330-MWth reactor called SMART. The Russian Federation has embarked on a nuclear desalination project using a series of barge-mounted units known as KLT-40C. India has become a front runner in demonstrating nuclear desalination by coupling new

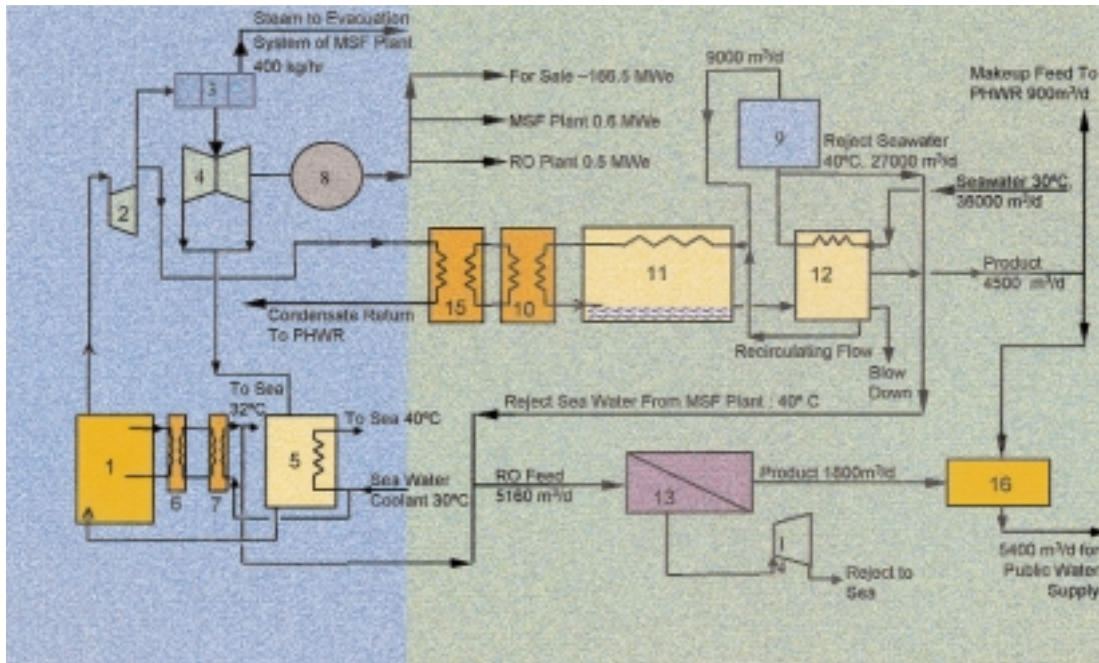

desalination facilities to its existing 170-MWe pressurized heavy water reactors (PHWRs). The construction work has started at Kalpakkam, south of Chennai.

In 1999, the IAEA launched an interregional technical cooperation project, “Integrated Nuclear Power and Desalination System Design”, to facilitate collaboration between technology holders and potential end-users. The project aims to provide a forum for technology suppliers and prospective recipients for the joint development of integrated nuclear desalination concepts, aiming at the demonstration of the viability of nuclear desalination at specific sites.

Indonesia, Tunisia, Pakistan and Iran have made specific requests for technical assistance under this framework to initiate or plan feasibility studies under specific local conditions. Some other developing countries, which foresee greater energy and water problems, have also



INDIA'S NUCLEAR DESALINATION DEMONSTRATION PROJECT

Construction has started in Kalpakkam, India, on a nuclear desalination demonstration project, shown above. As shown in the diagram of the process flow, the desalination systems are coupled to a nuclear plant, a 170-MWe PHWR. The numbers in the diagram show the PHWR (1); the high-pressure turbine (2); the moisture separator/reheater (3); the low-pressure turbine (4); the power plant condenser (5); the moderator-water cooling loop (6); the water-seawater cooling loop (7); the generator (8); the multi-stage flash (MSF) plant chemical pretreatment section (9); the MSF plant brine heater (10); the MSF plant heat recovery section (11); the MSF plant heat reject section (12); the reverse osmosis (RO) plant (13); the RO plant energy recovery turbine (14); the intermediate heat exchanger (15); and the product storage tank (16).

indicated strong interests in participating in the project.

Prospective technology suppliers involved in international collaborative efforts include the Republic of Korea, Russian Federation, Argentina, Canada, France, and China.

In line with these IAEA activities, demonstration projects are being planned and evaluated in several countries. They aim to demonstrate the feasibility of using nuclear energy for desalination applications under specific conditions.

Morocco completed its pre-project study in 1998 jointly with China, using a 10-MWth heating reactor that produces 8000 cubic meters per day of potable water by a multi-effect distillation process at Tan-Tan. Egypt initiated a feasibility study in 1999 of a cogenerating plant for electricity and potable water production at El-Dabaa along the Mediterranean coast.

Demonstration Project in India. The Bhabha Atomic Research Centre (BARC) has been engaged in research and development of desalination since the 1970s with a view to augment water sources in areas of scarcity. As a result, multi-stage flash (MSF) and reverse osmosis (RO) technologies were developed indigenously.

In order to gainfully utilize the experience and expertise in various aspects of desalination activity, BARC is seeking to set up a hybrid MSF-RO desalination demonstration plant coupled to the 170-MWe PHWR units operating at the Madras Atomic Power Station (MAPS) at Kalpakkam, in southeast India. (*See box, page 7.*)

The Nuclear Desalination Demonstration Project (NDDP) includes an MSF plant with a capacity of 4500 cubic meters per day along with an RO plant having a capacity of 1800 cubic meters per day. Together they would provide enough desalted water to meet the dual needs of process water for the nuclear power plant and of drinking water for the neighbouring people.

Objectives of the demonstration plant are:

- to establish the indigenous capability for the design, manufacture, installation and operation of nuclear desalination plants;
- to generate necessary design inputs and optimum process parameters for a large-scale nuclear desalination plant;
- to serve as a demonstration project for interested IAEA Member States, whose participation is welcome.

The project at Kalpakkam started in 1998. The preliminary safety analysis report (PSAR) and preliminary design basis report were prepared. The major equipment is now in various stages of procurement or fabrication. The civil work is in progress and the buildings housing the MSF and RO plants, as well as administration, are nearing completion. The PSAR has been approved and the final safety analysis report (FSAR) is being prepared for submission.

Most of the equipment will reach the site in 2002 when installation can begin. Trial runs and commissioning are envisaged later in 2002. On completion of the commissioning test, the NDDP

will be open to international participation by interested Member States under the IAEA umbrella in order to share the relevant information of operation and maintenance of a nuclear desalination plant.

Based on project experience, the completion of standardized plants with a capacity of 10 million gallons a day would be completed by the year 2005. The plants would use both the MSF and RO processes and become available for commercial use in the country.

Sharing Experience. For large-scale deployment of nuclear desalination, one of the most decisive factors, even if not the only one, is economic competitiveness. Operating experience in Kazakhstan and in Japan may not be a strong indicator of economic viability in many developing countries now considering nuclear desalination.

Strongly needed is the demonstration of economic viability under local conditions in more countries. Successful commissioning and operation of the Kalpakkam plant in India will deepen technical and economic confidence in nuclear desalination. Importantly, the plant's operation and maintenance experience will be shared with other interested countries.

In 2002, the IAEA is planning an international symposium to review and update the global status of nuclear desalination. As more experience is gained and shared, countries will be able to more fully assess the role that this multi-faceted nuclear technology can play to meet rising electricity and water needs. □