



PROCEEDINGS OF A SYMPOSIUM
VIENNA

16-20 NOVEMBER 1987

JOINTLY ORGANIZED BY IAEA AND FAO



Modern Insect Control: Nuclear Techniques and Biotechnology



INTERNATIONAL ATOMIC ENERGY AGENCY, VIENNA, 1988

**MODERN INSECT CONTROL:
NUCLEAR TECHNIQUES AND BIOTECHNOLOGY**

PROCEEDINGS SERIES

**MODERN INSECT CONTROL:
NUCLEAR TECHNIQUES
AND BIOTECHNOLOGY**

PROCEEDINGS OF AN INTERNATIONAL SYMPOSIUM
ON MODERN INSECT CONTROL:
NUCLEAR TECHNIQUES AND BIOTECHNOLOGY
JOINTLY ORGANIZED BY THE
INTERNATIONAL ATOMIC ENERGY AGENCY
AND THE
FOOD AND AGRICULTURE ORGANIZATION
OF THE UNITED NATIONS
AND HELD IN VIENNA, 16-20 NOVEMBER 1987

INTERNATIONAL ATOMIC ENERGY AGENCY
VIENNA, 1988

**MODERN INSECT CONTROL:
NUCLEAR TECHNIQUES AND BIOTECHNOLOGY**
IAEA, VIENNA, 1988
STI/PUB/763
ISBN 92-0-010388-X
ISSN 0074-1884

© IAEA, 1988

Permission to reproduce or translate the information contained in this publication may be obtained by writing to the International Atomic Energy Agency, Wagramerstrasse 5, P.O. Box 100, A-1400 Vienna, Austria.

Printed by the IAEA in Austria
July 1988

FOREWORD

Insect control is essential in the production of crop and animal produce. The ravages of insects in tropical and subtropical zones of the world, where most developing countries are located, are particularly serious. There are two overriding problems or issues facing insect control specialists throughout the world. These are the rapid development of resistance to insecticides by a large number of insect species, coupled with the reduced rate at which new insecticides are being developed, and the increasing environmental concerns about the continued use of many agrochemicals, including insecticides, and the all too frequent misuse of these chemicals.

Most insects are controlled by the use of insecticides which are applied by individual farmers on a field by field basis. The area wide approach to insect control, where a particularly damaging species of insect is controlled over a large geographical or crop production area, is currently under more favourable consideration than in the past. The area wide approach must be used against certain types of insect pests, such as mosquitoes, locusts, tsetse flies, etc. One of the primary reasons why area wide control is being more favourably considered is the development of a number of new insect control technologies which are only applicable on an area wide basis. These include the sterile insect technique (SIT); pheromones which are applied over large areas, resulting in confusion of the sexes so that mating does not take place; and inundative release of parasites and predators.

The International Symposium on Modern Insect Control: Nuclear Techniques and Biotechnology, held in Vienna from 16 to 20 November 1987 and sponsored by the Food and Agriculture Organization of the United Nations and the International Atomic Energy Agency, dealt primarily with genetic methods of insect control, including SIT, F_1 sterility, compound chromosomes, translocations and conditional lethals. Research and development activities on various aspects of these control technologies were reported by participants during the Symposium. Of particular interest was the development of F_1 sterility as a practical method of controlling pest Lepidoptera.

Genetic methods of insect control are applicable only on an area wide basis. They are species specific and thus do not reduce populations of beneficial insects or cause other environmental problems. Further, the problem of the target species becoming resistant to the control technology is avoided with genetic methods of insect control.

Other papers presented reported on the potential use of radiation as a quarantine treatment for commodities in international trade and the use of radioisotopes as 'tags' in studying insects.

The Symposium was attended by 70 participants from 34 countries and four international organizations. Forty-eight papers were presented and are included in these Proceedings.

EDITORIAL NOTE

The Proceedings have been edited by the editorial staff of the IAEA to the extent considered necessary for the reader's assistance. The views expressed remain, however, the responsibility of the named authors or participants. In addition, the views are not necessarily those of the governments of the nominating Member States or of the nominating organizations.

The use of particular designations of countries or territories does not imply any judgement by the publisher, the IAEA, as to the legal status of such countries or territories, of their authorities and institutions or of the delimitation of their boundaries.

The mention of names of specific companies or products (whether or not indicated as registered) does not imply any intention to infringe proprietary rights, nor should it be construed as an endorsement or recommendation on the part of the IAEA.

The authors are responsible for having obtained the necessary permission for the IAEA to reproduce, translate or use material from sources already protected by copyrights.

Material prepared by authors who are in contractual relation with governments is copyrighted by the IAEA, as publisher, only to the extent permitted by the appropriate national regulations.

CONTENTS

NUCLEAR TECHNIQUES IN INSECT CONTROL: PAST, PRESENT AND FUTURE (Session 1)

Radiation, insects and eradication in North America: An overview from screwworm to bollworm (IAEA-SM-301/29)	3
<i>J.W. Snow</i>	
Status and potential of F ₁ sterility for control of noxious Lepidoptera (IAEA-SM-301/41)	15
<i>V.C. Mastro, C.P. Schwalbe</i>	
A genetic perspective on pest control and the future of autocidal control (IAEA-SM-301/42)	41
<i>M.J. Whitten</i>	

BIOTECHNOLOGY IN INSECT CONTROL (Session 2)

Biotechnologies et lutte contre l'onchocercose (IAEA-SM-301/30)	59
<i>R. Le Berre</i>	
Investigations on sex linked recessive lethal mutations as a possible mechanism for the genetic control of lepidopterous pests (IAEA-SM-301/45)	65
<i>A.I. Anisimov</i>	
Diversity among <i>Bacillus thuringiensis</i> active against the Mediterranean fruit fly, <i>Ceratitis capitata</i> (IAEA-SM-301/31)	77
<i>R.E. Gingrich, T.S. El-Abbassi</i>	
Induction and use of sex linked lethal mutations in the pink bollworm (IAEA-SM-301/26)	85
<i>A.C. Bartlett</i>	

Poster Presentations

The nuclear polyhedrosis virus of the fall webworm, <i>Hyphantria cunea</i> , for the development of viral pesticides in the Republic of Korea (IAEA-SM-301/5P)	97
<i>H.Y. Park, J.I. Kim, K.S. Ryoo, S.K. Kang</i>	
Cytoplasmic incompatibility for suppression of <i>Ephesthia cautella</i> infestation rate in simulated date stores (IAEA-SM-301/12P)	102
<i>M.S.H. Ahmed</i>	

GENETIC APPROACHES TO INSECT CONTROL (Session 3)

Organization of medfly eradication campaigns (IAEA-SM-301/9)	107
<i>J. Reyes, A. Villaseñor, A. Schwarz, J. Hendrichs</i>	
Programa de erradicacion de la mosca del Mediterráneo en Guatemala (IAEA-SM-301/32)	117
<i>F. Hentze</i>	
The sterile insect technique and its role in integrated trypanosomiasis control programmes (IAEA-SM-301/33)	129
<i>A.M.V. Van Der Vloedt, J.P. Kabayo, E.D. Offori, D. Luger</i>	
Epidemiological survey in the pastoral zone of Sidéradougou, Burkina Faso (IAEA-SM-301/44)	139
<i>B. Bauer, J. Petrich-Bauer, I. Kaboré, B. Kourouma, M. Mattausch, J. Somé, I. Tamboura</i>	
Seasonal sex ratio distortion in <i>Glossina tachinoides</i> Westwood populations inhabiting peridomestic agro-ecosystems of the Nsukka area, Anambra State, Nigeria, in relation to the sterile insect technique (IAEA-SM-301/11)	151
<i>L.C. Madubunyi</i>	
Genetics as a component of vector mosquito control in East Africa (IAEA-SM-301/34)	163
<i>T.K. Mukiana</i>	
Genetic methods for control of mosquitoes and biting flies (IAEA-SM-301/37)	179
<i>J.A. Seawright</i>	

GENETIC APPROACHES TO INSECT CONTROL (cont.) (Session 4)

Temperature dependent sex ratio distortion after X-irradiation of medfly males (IAEA-SM-301/25)	195
<i>R.J. Wood, R.M. Shahjahan</i>	
Genetic method for separation of males and females of the medfly on the basis of pupal colour (IAEA-SM-301/8)	205
<i>J.M.M. Walder</i>	
Isolation and mass rearing of a pupal genetic sexing strain of the Mediterranean fruit fly, <i>Ceratitidis capitata</i> (Wied.) (IAEA-SM-301/35)	211
<i>E. Busch-Petersen, J. Ripfel, A. Pyrek, A. Kafu</i>	
Updating of the genetics of <i>Ceratitidis capitata</i> (Wied.) (IAEA-SM-301/43) ...	221
<i>A.R. Malacrida, G. Gasperi, L. Baruffi, G.F. Biscaldi, R. Milani</i>	
Selection for resistance in the Mediterranean fruit fly for genetic sexing in sterile insect technique programmes (IAEA-SM-301/36)	229
<i>Y. Rössler</i>	

Status of molecular genetic studies in the medfly, <i>Ceratitis capitata</i> , in relation to genetic sexing (IAEA-SM-301/38)	241
<i>A.S. Robinson, C. Savakis, C. Louis</i>	
The Mediterranean fruit fly: Progress in developing a genetic sexing strain using genetic engineering methodology (IAEA-SM-301/28)	251
<i>D.O. McInnis, S.Y.T. Tam, C.R. Grace, L.J. Heilmann, J.B. Courtright, A.K. Kumaran</i>	
Génie génétique chez les insectes: Clonage et transgénose de gènes de résistance aux insecticides (IAEA-SM-301/23)	257
<i>C. Mouches</i>	
Competitiveness of irradiated adults of the almond moth (IAEA-SM-301/17)	263
<i>M.Y.Y. Ahmed, S.A. El-Refai, E.A. El-Kady, Z.A. Hasaballa</i>	

INSECT REARING AND QUALITY CONTROL (Session 5)

In vitro rearing of <i>Glossina austeni</i> Newstead for the sterile insect technique in Tanzania (IAEA-SM-301/12)	271
<i>C.S. Tarimo, F.W. Makishe, M.K. Gao</i>	
Development of synthetic diets and their use in studies on tsetse fly nutrition (IAEA-SM-301/40)	277
<i>J.P. Kabayo, M. Taher, H. Barnor</i>	
Quality evaluation of the mass reared Asian corn borer, <i>Ostrinia furnacalis</i> Guenée (IAEA-SM-301/5)	281
<i>Darong Zhou, Zhenying Wang</i>	
Recent developments in medfly mass rearing (IAEA-SM-301/39)	285
<i>A.P. Economopoulos, N.D. Bruzzone, S. Judt, V. Wornoayporn, M.N. El-Agal, A.A. Al-Taweel, Hua-Song Wang</i>	
Gamma irradiation of the Mediterranean fruit fly (<i>Ceratitis capitata</i> Wied.): Emergence, longevity, sterility and sexual competitiveness after treatment in air and partial nitrogen (IAEA-SM-301/10)	293
<i>A. Zümreoğlu, K. Akman</i>	
Irradiation/sterilization techniques for <i>Anastrepha suspensa</i> Loew and their impact on behavioural quality (IAEA-SM-301/27)	299
<i>C.O. Calkins, K.A.A. Draz, B.J. Smittle</i>	
Efectos geneticos y ambientales sobre el peso de <i>Lixophaga diatraeae</i> (Diptera:Tachinidae) a diferentes edades (IAEA-SM-301/46)	307
<i>J.L. Goicoechea, J. Aleman, Y. Fraga, A. Perez</i>	

LETHAL EFFECTS OF RADIATION (FOOD DISINFESTATION)

(Session 6)

Irradiation as a quarantine treatment for the Oriental fruit fly, <i>Dacus dorsalis</i> Hendel, in mangoes (IAEA-SM-301/16)	319
<i>Puangpaka Komson, Manon Sutantawong, Eueychai Smitasiri, Chamlong Lapasatukul, Udorn Unahawutti</i>	
Intérêt de l'irradiation pour la destruction des nymphes diapausantes de mineuse cerclée (Lepidoptère:Lyonetiidae) (IAEA-SM-301/22)	325
<i>P. Ducom, L.A. Buscarlet, R. Mekdoud, J.-P. Cugier</i>	
Effect of gamma radiation treatment on the mortality of the flour beetle (IAEA-SM-301/6)	337
<i>Z. Zare, F. Toofanian</i>	
Stored rice wholesomeness and the control of mite and psocid pests with gamma radiation (IAEA-SM-301/2)	343
<i>J. Zuska, Z. Kučerová, J. Sedláčková</i>	
Combination of gamma radiation and elevated temperature as a quarantine treatment against two principal stored date insect species (IAEA-SM-301/7)	357
<i>M.S.H. Ahmed, A.A. Al-Taweel, A.A. Hameed, H. Auda</i>	
Effects of gamma radiation on testes and on the reproductive ability of the Mediterranean flour moth, <i>Anagasta kuhniella</i> Zell. (Lepidoptera:Phycitidae) (IAEA-SM-301/4)	369
<i>J. Rosada</i>	

Poster Presentation

Potential of radiation as a quarantine treatment for the mould mite, <i>Tyrophagus putrescentiae</i> (Schrank), in agricultural products (IAEA-SM-301/10P)	381
<i>S. Ignatowicz</i>	

SUBLETHAL EFFECTS OF RADIATION (Session 7)

Mating competitiveness of radiation sterilized greenhouse whiteflies (IAEA-SM-301/1)	387
<i>N. Genchev</i>	
Effects of irradiation and exposure to nitrogen on the free amino acid content of <i>Tribolium confusum</i> J. du Val. (Coleoptera:Tenebrionidae) (IAEA-SM-301/21)	395
<i>L.A. Buscarlet, J.L. Ravenel, S.R. Kassis</i>	

The inherited sterility of the corn borer (<i>Ostrinia furnacalis</i> Guen.) (IAEA-SM-301/13)	403
<i>Y.Y. Li, H.Q. Zhang, H.Z. Lou, C.D. Zhao</i>	
Parental and inherited sterility induced by gamma radiation in male moths of the maize borer, <i>Chilo partellus</i> (Swinhoe) (IAEA-SM-301/15)	413
<i>A.R. Bughio</i>	

Poster Presentation

Radiation induced genetic damages influencing the suppressive effect of inherited sterility in the codling moth (IAEA-SM-301/2P)	423
<i>A.I. Anisimov, N.V. Lazurkina, A.N. Shvedov</i>	

ISOTOPES AS LABELS (Session 8)

Studies on the predator-prey relationship between <i>Oecophylla smaragdina</i> and <i>Helopeltis theobromae</i> using the radiotracer technique (IAEA-SM-301/14)	427
<i>P.K. Chin, A.B. Sipat, K.C. Khoo</i>	
Use of radioisotopes to elucidate the role of regurgitation for direct transfer of parasites or disease agents between host organisms through arthropod vectors (IAEA-SM-301/24)	437
<i>W.J. Kloft, G.H. Hesse</i>	
Utilisation de l'iridium 191 et de l'azote 15 pour le marquage d'insectes du colza d'hiver (IAEA-SM-301/20)	451
<i>Y. Ballanger, L.A. Buscarlet</i>	
Nutritional and ecological research using nuclear techniques for the control of the olive fruit fly (IAEA-SM-301/3)	461
<i>A.G. Manoukas</i>	
Chairmen of Sessions and Secretariat of the Symposium	467
List of Participants	469
Author Index	477
Index of Papers and Posters by Number	479

**NUCLEAR TECHNIQUES IN INSECT CONTROL:
PAST, PRESENT AND FUTURE**

(Session 1)

Chairman

**L.E. LaCHANCE
FAO/IAEA**

Invited Paper

RADIATION, INSECTS AND ERADICATION IN NORTH AMERICA

An overview from screwworm to bollworm

J.W. SNOW

Southeastern Fruit and Tree Nut Research Laboratory,
Agricultural Research Service,
United States Department of Agriculture,
Byron, Georgia,
United States of America

Abstract

RADIATION, INSECTS AND ERADICATION IN NORTH AMERICA: AN OVERVIEW FROM SCREWWORM TO BOLLWORM.

Research on the use of radiation as a method to eradicate or suppress insect populations in a total ecosystem was first initiated in 1949. In the thirty-eight years since then, its use has proved to be an entomological marvel in that many successful programmes have been implemented or are under active research. The first and most impressive was that against the screwworm, *Cochliomyia hominivorax* (Coquerel), which was totally eradicated from North America, and with a new programme just initiated to eradicate the pest from Central America. Sterile insects have also been successfully used to eradicate outbreaks of fruit flies in Florida and California. The Mediterranean fruit fly, *Ceratitis capitata* (Wiedemann), has also been eradicated from all of Mexico using this technique. Radiation and sterile insects are actively being researched as possible components of the boll weevil (*Anthonomus grandis grandis* Boheman) eradication programme as complementary additions to the use of insecticides and trapping. These programmes will be reviewed in detail, along with recent progress on the two *Heliothis* species, probably the most economically important insect species in North America.

1. INTRODUCTION

Since the beginning of time man has had to cope with insect problems. Usually the insects were held in check by natural forces, but in those cases where outbreaks did occur, most or all of his crop would or could be destroyed. Based on this constant pursuit of ways to eliminate or reduce losses, it is valid to say that the relationship between man and harmful insects has been unsatisfactory. Therefore, insects must be controlled because the alternative is an erratic food supply and a poorer general standard of living. Thus, in modern entomology, to control insects is not the issue but rather how to control them. The most effective method is the use of insecticides, and probably 95% of the insect pests are controlled in this way. This is because insecticides are cost effective, easy to apply and usually obtain good results. These factors

TABLE I. INSECTS FROM NORTH AMERICA ON WHICH RADIATION HAS BEEN USED OR WHICH HAVE BEEN STUDIED EXTENSIVELY TO SUPPRESS OR ERADICATE POPULATIONS

Common name	Scientific name
Corn earworm	<i>Heliothis zea</i>
Tobacco budworm	<i>Heliothis virescens</i>
Tobacco hornworm	<i>Manduca sexta</i>
Boll weevil	<i>Anthonomus grandis</i>
Pink bollworm	<i>Pectinophora gossypiella</i>
Gypsy moth	<i>Lymantria dispar</i>
Mediterranean fruit fly	<i>Ceratitis capitata</i>
Oriental fruit fly	<i>Dacus dorsalis</i>
Melon fly	<i>Dacus cucurbitae</i>
Screwworm	<i>Cochitomyia hominivorax</i>
Mexican fruit fly	<i>Anastrepha ludens</i>
Codling moth	<i>Cydia pomonella</i>
Common malaria mosquito	<i>Anopheles quadrimaculatus</i>

have led to their overuse and eventually created many of the problems we have today with resistance and environmental pollution. Nevertheless, insecticides will remain the most important way to control insects regardless of any alternative methods we develop.

However, many of the pests, particularly those that are the most economically important, or have human health hazards associated with them, are viable targets for large scale suppression or eradication programmes. In some cases, sterility and radiation may be the only components of control, but equally likely is that parasites, predators, pathogens, pheromones, etc., will be minor or major parts of the control effort. Knipling [1] considers total insect population suppression as the most rational way of dealing with many major arthropod pest problems. Most entomologists agree with this assessment and the subject of this paper is the role of radiation in that process in North America. The insects against which radiation has been used for their control, or which have been extensively studied as a potential control are listed in Table I. The most important programmes will be considered under a separate heading.

1.1. Screwworm

The most successful and best known programme is the screwworm eradication programme, which has been operational since 1958 [2]. So far, the species has been



FIG. 1. A human case of screwworms where eggs were laid in the nasal passage.

eradicated from Curaçao, south-eastern USA, Puerto Rico, south-western USA and Mexico. The savings thus far are estimated at around US \$4 thousand million to the countries involved [3]. The screwworm is an obligate dipterous parasite of all warm blooded animals and the principal hosts are cattle, hogs, sheep and goats, but rabbits, deer, squirrels, and even chickens also serve as hosts. Man is often attacked and a severe human case is shown in Fig. 1. Death occurs in about 10% of the human cases. The insect is of tropical origin and can survive in all of Mexico, but only in the warm areas of the USA, principally, the extreme southern parts of Texas, Arizona, New Mexico and Florida. However, during the spring and summer it used to migrate from this limited area and cover most of the USA. Its movement was both by migration and through the shipment of infested animals to market. The screwworm is of great

TABLE II. THEORETICAL COMPARISON OF THE EFFECTIVENESS OF AN INSECTICIDE (90% KILL) AND STERILE INSECTS (9000/GENERATION) AS A CONTROL

Generation	Uncontrolled ^a population	Sterile insects	Insecticides
1	1 000	1000	1000
2	5 000	500	500
3	25 000	132	250
4	125 000	95	125
5	625 000	5	63
6	625 000	0	31
7	625 000	—	16
8	625 000	—	8
9	625 000	—	4
10	625 000	—	2

^a Assumes a fivefold increase each generation with a maximum possible population of 625 000.

economic importance, as established in this excerpt from a letter written in 1888 by W.G. Curtis (at that time the Texas Agricultural Experiment Station Director):

“I am free to confess that the man who can find a cheap, expeditious, and effective prevention or remedy of the screwworm will confer a blessing fitly measured by the enormous financial benefits that will occur.”

The man who finally developed the concept that would eventually control the screwworm in the total ecosystem was E.F. Knipling [1]. He realized in the late 1930s that a chance existed that the species could be eradicated if some method to sterilize it could be found.

The first attempts were with chemosterilants, which were unsuccessful. It was not until A.W. Lindquist, a long time associate of Knipling, read an article by Muller [4], that was written in 1950 on the genetic effects of radiation, that the method to sterilize insects finally become apparent. Research began immediately on radiation in Kerrville, Texas, and the first paper demonstrating sterility was published in 1951 [5].

The concept itself is relatively simple and a theoretical example for ten generations that compares the effects of sterile insects to insecticides is shown in Table II. A beginning population of 1000 insects is used in the example and a fivefold increase per generation and a maximum population of 625 000 individuals is also assumed.

The insecticide is considered to kill 90% of the insects each generation and the 9000 sterile insects (that are released each generation) are considered to be fully competitive. In this example, the sterile insects completely eradicate the population within five generations. This is because the ratio of sterile to fertile insects increases with each generation and escalates the downward trend in the population. The insecticide only reduces the population by one-half in each generation in this theoretical example.

It is this concept, and the importance of the screwworm, that led to the eventual development of the screwworm eradication programme. In hindsight, the choice of the screwworm as the first target insect was fortunate because rearing methods could be developed, the insect occurred in low numbers in nature and the female mated singly. Thus, sperm level competitiveness was not a factor. Also, the species was sterilized at a relatively low dosage, about 7 krad¹, and little somatic damage occurred. Had another species been selected as the first target species the concept might have never been developed.

In the USA, cattlemen have always participated in the financial support of the programme. This was very important because it ensured rancher support, which was vital for the programme's success. The same philosophy is now being used in the boll weevil eradication programme, in that farmers are required to pay about 70% of the total cost of the programme. A critical element in all programmes is a need to reduce the natural screwworm population and this was accomplished by the treatment of wounds and reduction in oviposition sites by the control of calving and limiting branding, dehorning, etc., to the times of the year when screwworms were not present.

Following the successful eradication of the screwworm from Mexico in 1985, the Governments of Mexico and the USA indicated a willingness to continue the programme into Central America down to the Darien Gap in Panama. Figure 2 shows the general plan for this new programme [6]. Eradication will be difficult because of the favourable conditions for screwworm reproduction and survival. However, no technical obstacles exist that will prevent eradication if scientific practices and procedures already established are followed. The many national borders and political sensitivities will impede the programme unless each country co-operates. However, eventually the programme will be implemented because the screwworm is too important to the economies of the countries for them not to reach a political solution eventually. So far, agreements have been signed with Guatemala and Belize. The eradication will have to progress in zones because sufficient sterile flies cannot be produced to eradicate these insect populations in all of the countries at once. About two years will be required in each zone and the entire programme is estimated to cost about US \$200 million [6].

¹ 1 rad = 1.00 × 10⁻² Gy.

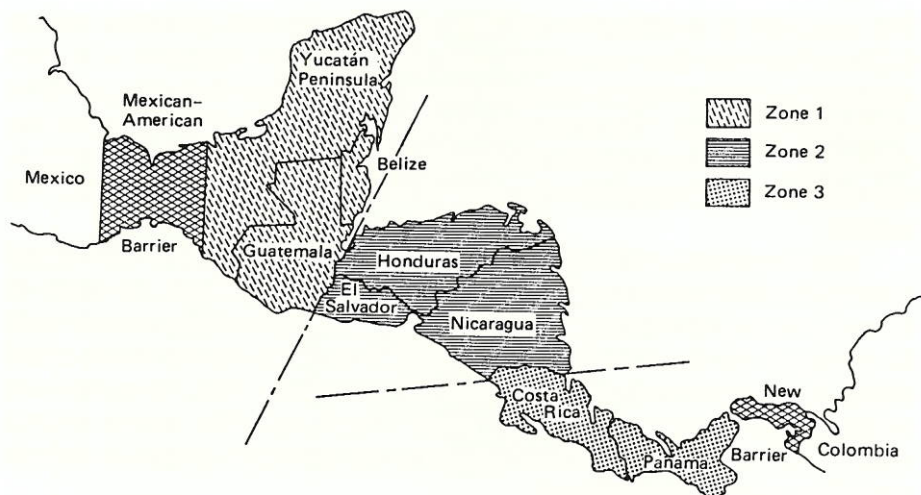

FIG. 2. Zones of eradication and the sterile fly barrier for a proposed screwworm eradication programme in Central America.

1.2. Lepidoptera

This is perhaps the most targeted group of insects, but so far it also seems to be the most difficult in which to realize successes. This is principally because of traditional rearing difficulties, both with the quantity and quality of insects, which have usually resulted in too few insects that lacked copulation and sperm level competitiveness. This is certainly true from the author's personal experience with the tobacco budworm and corn earworm, although the tobacco hornworm research was less complex. These experiments were all conducted on the small Caribbean island of St. Croix, the United States Virgin Islands, which is located about 129 km east of Puerto Rico. The island is about 217 km, 42 km long and 10 km in diameter, at the widest part.

In experiments to eradicate the tobacco hornworm from this island, the attempt was relatively easy and straightforward [7]. The population was low because of an earlier control programme using light traps and enough insects could be reared in the laboratory to produce high ratios of sterile to fertile males. Also, the females mate only once and the males were almost 100% competitive. Only males were released and they lead to a quick reduction in the natural population to about 99% of the level originally encountered. The species could have been totally eradicated had we not abandoned the project to move on to the more important *Heliothis* species. Thus, the technology was sound and is probably the best straightforward example of the control of a lepidopterous pest using sterile insects. Unfortunately, we broke the rule and developed a programme for a species that was not sufficiently important to justify the

time, energy and money to go on to the next step. In addition, the hornworm is not typical of Lepidoptera.

In this paper only *H. zea* will be considered because this research represents that species as well as *H. virescens*. First, the population of corn earworms on St. Croix was estimated by radioactively labelling a 0.25 hectare corn field with ^{32}P . It was located in the centre of the island and all the corn earworms that developed on this corn were radioactive. We were able to estimate the population and obtain distribution data based on recoveries in light and virgin female traps. We determined that the population was within our rearing ability, so a programme using total sterility was begun. Also, we had learned that 90% of the resident population of corn earworms lived within the few hectares of corn that were always available on the island. Had eradication been our only goal, it would have been easy to reduce the population to almost nothing by destruction of the corn or by its treatment with insecticides. This would have ensured rapid success, but our intent was to study the concept; therefore, a strong population was desired. In this case, when males only were released, the population was totally unaffected by our release, an indication that either a total incompatibility of the reared insects existed or that they totally lacked competitiveness. Experiments were conducted that proved the latter to be the case. This has proved to be the most important data to come from St. Croix, because it so clearly showed how poorly our laboratory insects performed and provided an insight into the research needed to improve the chances for eventual success. It also gave a valuable insight into how fragile competitiveness was and how it could be manipulated in very subtle ways [8].

We found that by the inclusion of females in the release, competitiveness could be altered to near 100%. Figure 3 gives a hypothetical example of how this competitiveness can be altered. In this example, wild male mating potential is considered to be three times greater than the female potential. This assumption is based on the fact that males are available to mate each night, while females average only two to three matings in their lifetimes. We also assumed that wild males would mate with the available females first and only 'excess' females would mate with the laboratory males. As seen in the example, laboratory males were unable to copulate regardless of the ratio as long as enough wild males were available to mate. This was shown to be experimentally true in St. Croix, where distance was not a factor because the releases were made in corn fields where the natural population was also located. The laboratory males' inability to mate continued regardless of the ratio until the number of females released exceeded the number of wild males available for mates. As the number of females released increased, so did the apparent male competitiveness, reaching full competitiveness when the total number of males available equalled the total number of females available (males only mate once a night). Thus the laboratory males were unable to mate until a situation of 'no competitiveness' was reached. However, from a technical standpoint, the laboratory males can be 0 to 100% competitive depending on the number of females in the area. Experimentally, this competitiveness was also enhanced because released females 'called' earlier than

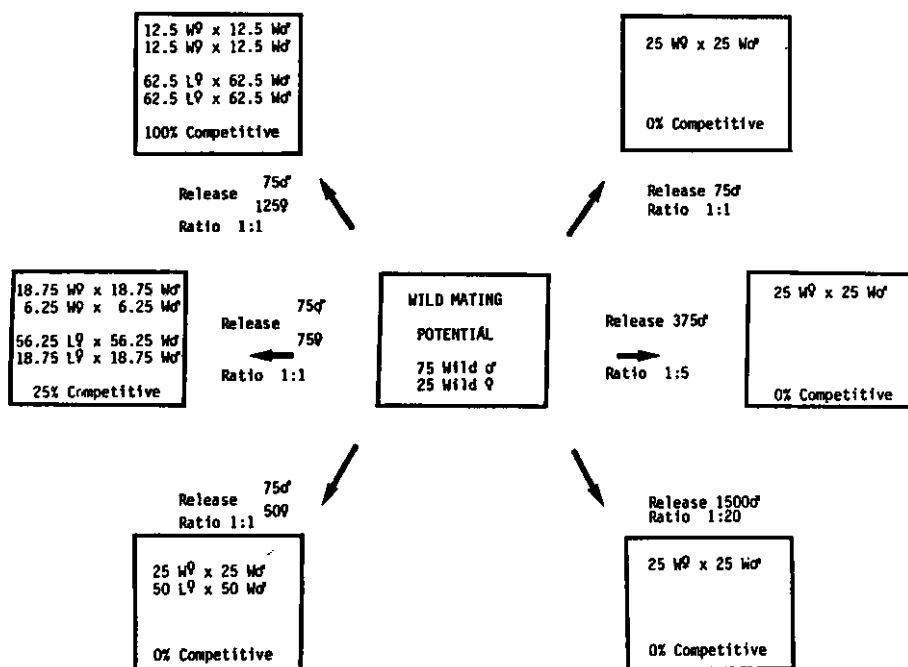

FIG. 3. Hypothetical mating situation showing laboratory males non-competitive until laboratory females are added to the release.

wild females and the wild males were tied up rapidly with these females. Consequently, when wild females called a few hours later only sterile males were available as mates.

However, after copulation competitiveness was achieved, the sperm from radiated males was then found to be non-competitive [9]. Sperm from the laboratory reared and sterilized insects was almost always displayed when a mating occurred with a wild male. This same phenomenon did not occur when wild insects were irradiated and sequentially mated with females. I am sure this will be discussed more in later papers as it is typical of the problems encountered in Lepidoptera. Despite this, the population was eventually reduced by about 90%, but this did not represent a workable programme [10]. Chemical control of *Heliothis* accounts for about 50% of all insecticides used in the USA and for that reason research will certainly continue to develop area wide control methods.

1.3. Boll weevil

A new eradication programme has been developed and initiated in the USA and, like the screwworm programme, success or failure will have a great impact on

entomology. While it does not now have radiation as a component, this is currently under test and will likely be incorporated into the programme by next year. The boll weevil is another tropical insect that invaded the USA from Mexico in 1892 and by 1928 it had spread to all of the cotton producing areas of the USA east of the high plains of Texas. It drastically changed agriculture in the southern USA because the boll weevil eliminated cotton as a viable crop for several years, thus forcing a diversification in agriculture which eventually improved agriculture in the region. The boll weevil is a relatively easy pest to control, but once chemicals are used, *Heliothis* problems develop because of the destruction of beneficial insects. In 1950, Brazzel et al. [11] published a scheme to control boll weevils in cotton fields by insecticides in the late season after diapause has begun, but before weevils had gone into hibernation. While control on a field to field basis was unsuccessful, it was realized that the possibility existed for area wide control if all growers within an area treated the diapausing population. The idea is short term heavy pesticide use to prevent long term pesticide abuse. With the discovery of the pheromone, an additional way to detect and even control the insect during times of low populations became available. Thus, the eradication programme was developed using these two components, diapause weevil control with insecticides followed by trapping.

Sterile insects were not included because a suitable method could not be developed to sterilize weevils owing to the sensitivity of their mid-gut to radiation damage at the dosage rates necessary to sterilize female weevils that had mated prior to radiation. However, only 10 krad, a non-debilitating dosage, is required to sterilize males and non-mated females. Now a high quality sterile weevil is being produced by using a combination of 10 krad of radiation for the sterile males and non-mated females and then they are dipped in a solution of Dimilan® to sterilize the gravid females. It is planned to use sterile weevils around cities, homes, etc., where pesticides cannot be used. Also, they will be used in combination with traps to eliminate outbreaks of the pest within the eradicated zone. This will prevent *Heliothis* problems in these isolated situations. Currently, rearing technology or the funds associated with the programme do not permit the use of sterile insects as a major programme component. The programme is now four years old and the pest has been eliminated from Virginia, North Carolina and South Carolina. The new programme is phase 2 and has begun in Georgia, Alabama and Florida.

1.4. Fruit flies

Much the same problem exists with fruit flies. In the last 20 years many outbreaks have occurred in the USA and more and more insecticides, applied alone or in bait sprays, are coming under criticism from environmentalists. Therefore the use of insecticides to lower a population in conjunction with the later release of sterile insects is becoming unacceptable. The USDA-ARS Hawaiian Laboratory is involved in using parasites to lower the population much as we have used insecticides in earlier programmes. The idea is to release both larval and egg parasites which reduce the

population to a low level where sterile insects can then do their job. The research is currently being tested on the islands of Maui and Roda in the Pacific. It is likely that this parasite-sterility concept will replace bait sprays-sterility as the method of choice in eradicating the periodic outbreaks of fruit flies in the USA.

2. SUMMARY

This paper cannot be ended without a brief discussion of eradication as a concept and the criticisms that always develop in association with any large programme. If the principles discussed are followed, such as the selection of an economic pest, and the biology and ecology have been well studied, then the concept is valid. Of course, the chance exists that the eradicated species may be replaced by an even greater pest, but we cannot make a decision not to eradicate on the fear of an unknown or potential problem. The concept of eradication of diseases has existed in medicine for a long time and its validity can be equally applied to insects. Who would want to live with the black plague, malaria, or yellow fever? Who would believe that the new world would be better if screwworms still existed in the eradicated areas? Eradication as a concept was discussed well by the National Academy of Sciences [12], in 1969, when it was said:

“There is nothing ecologically abhorrent about the eradication of a species. The geological record shows that many species have become extinct”. [And] “Well-organized and properly executed eradication programmes, armed with the necessary tools and proceeding from a base of thorough knowledge of the pest and its ecosystem, provide the ultimate solution to the problem of a number of noxious species”.

Turning to direct programme criticism, it usually comes from the misinformed or outsider who has no real understanding of the technology or operations of the programme. A good example of such unfounded criticism is a paper by Readshaw [13], in which he claims that weather can account for all of the successes of the screwworm programme. Of course, this is absolutely impossible, but it does demonstrate that criticism will always be present no matter how valid is a programme or how conclusive is the data. Any programme, to be successful, must be scientifically sound and have sufficient support to weather these criticisms. Examples in the USA, where this base of knowledge and ability to weather criticism were lacking, are the unsuccessful and now terminated programmes to eradicate the whitefringed beetle and imported fire ant.

As a final statement, area wide suppression and eradication programmes, for the most part, have served US agriculture well. They have provided a method to eliminate losses on a total basis and also, over the long haul, to reduce the levels of pesticide use, which translates into less environmental pollution. When all is weighed, radiation for insect control is a good technology for mankind to use in its

effort to provide food and fibre to people. Its use in insect control will certainly continue to grow as we gain more information about our major pests and how to handle them in an entire ecosystem.

REFERENCES

- [1] KNIPLING, E.F., *The Basic Principles of Insect Population Suppression and Management*, United States Department of Agriculture Handbook No. 512, USDA, Washington, DC (1979).
- [2] BAUMHOVER, A.H., Eradication of the screwworm fly, an agent of myiasis, *J. Am. Med. Assoc.* **196** (1958) 240-48.
- [3] KRAFSUR, E.S., WHITTEN, C.J., NOVY, J.E., Screwworm eradication in North and Central America, *Parasitol. Today* **3** (1987) 131-37.
- [4] MULLER, J.J., Radiation damage to genetic material, *Am. Sci.* **38** (1950) 33-59.
- [5] BUSHLAND, R.C., HOPKINS, D.E., Experiments with screwworm flies sterilized by X-rays, *J. Econ. Entomol.* **44** (1951) 725-31.
- [6] SNOW, J.W., WHITTEN, C.J., SALINAS, A., FERRER, J., SUDLOW, W.H., The screwworm, *Cochliomyia hominivorax* (Diptera: Calliphoridae), in Central America and proposed plans for its eradication south to the Darien Gap in Panama, *J. Med. Entomol.* **22** (1985) 353-60.
- [7] SNOW, J.W., et al., Control of the Tobacco Hornworm on St. Croix, U.S. Virgin Islands, By the Sterile Male Technique, Rep. ARS-5-98, USDA, Washington, DC (1976).
- [8] SNOW, J.W., CANTELO, W.W., BOWMAN, M.C., Distribution of the corn earworm on St. Croix, U.S. Virgin Islands, and its relationship to suppression programmes, *J. Econ. Entomol.* **62** (1969) 606-11.
- [9] NORTH, D.T., SNOW, J.W., HAILE, D., PROSHOLD, F.I., Corn earworms: Quality of sperm in sterile males released for population suppression on St. Croix Island, *J. Econ. Entomol.* **68** (1975) 595-8.
- [10] SNOW, J.W., BURTON, R.L., SPARKS, A.N., CANTELO, W.W., Attempted Eradication of the Corn Earworm from St. Croix, U.S. Virgin Islands, ARS Prod. RS. No. 125, USDA, Washington, DC (1971).
- [11] BRAZZEL, J.R., DAVICH, T.B., HARRIS, L.D., A new approach to boll weevil control, *J. Econ. Entomol.* **54** (1970) 723-30.
- [12] UNITED STATES NATIONAL ACADEMY OF SCIENCES, *Principles of Plant and Animal Pest Control*, Vol. 3, Insect Pest Management and Control Publication, Washington, DC (1969).
- [13] READSHAW, J.L., Screwworm eradication: a grand delusion? *Nature (London)* **320** (1986) 407-10.

Invited Paper

STATUS AND POTENTIAL OF F₁ STERILITY FOR CONTROL OF NOXIOUS LEPIDOPTERA

V. C. MASTRO, C. P. SCHWALBE

Animal and Plant Health Inspection Service,
United States Department of Agriculture,
Otis Methods Development Center,
Otis Air National Guard Base, Massachusetts,
United States of America

Abstract

STATUS AND POTENTIAL OF F₁ STERILITY FOR CONTROL OF NOXIOUS LEPIDOPTERA.

In certain lepidopterous insects, partially sterilized males mated with normal females produce progeny which are more sterile than their male parents. This phenomenon is known as inherited sterility and offers considerable advantages for suppression and eradication over conventional sterile insect methods. This phenomenon has been observed in numerous pests, including *Heliothis zea*, *Galleria mellonella*, *Ephestia cautella*, *Plodia interpunctella*, *Spodoptera frugiperda*, *Trichoplusia ni* and *Lymantria dispar*. Key findings that have advanced development of this technique are reviewed. Comparisons of several sterile insect methods are presented by means of simulation models. Recent research on gypsy moth has revealed a dramatic inherited sterility effect when male pupae are administered 10 krad of radiation. The F₁ sex ratio is two males to one female and those adults are completely sterile. Growth, development and behaviour of F₁ individuals indicates that they are highly competitive with normal insects. A major operational impediment to using the sterile insect method for Lepidoptera involves the release of, typically, rather large and fragile moths or pupae. This situation has been circumvented in the gypsy moth programme by releasing the normal females in the laboratory, and the resultant F₁ egg masses are collected and stockpiled for subsequent release into target infestations. These egg masses can be stored, are easily released from aircraft and, upon hatching, are 'implanted' into the target fertile population. This approach vastly simplifies the release of sterile insects. Field tests of the technique in isolated infestations of gypsy moths have indicated that the technique has promise and several eradication attempts have been successful. However, these studies have also identified a number of research imperatives, which are discussed.

Genetic control has been a part of insect population management for over thirty years. Extensive research into the radiation biology, behaviour and reproductive physiology of insect pests has enriched our understanding of the sterility mechanisms and factors that influence the effectiveness of sterile insect release programmes. Currently, this technology is in operational use against the screwworm fly, pink bollworm, Mediterranean fruit fly, Mexican fruit fly and other species and has been fully integrated into pest management programmes. The potential use of this technology has been demonstrated for dozens of other species, but operational deployment has

not materialized for a number of reasons. Probably foremost is the lack of incentive on the part of programme managers to adopt technology they 'really don't need'. Unless the sterile insect technique (SIT) provides advantages (i.e. economic, environmental, efficacy and social) not offered by conventional control technology, acceptance by pest management officials will likely be slow in coming. To be considered useful in an operational context, the entire continuum of activities associated with deploying the technique needs to be developed. Rearing, packaging, delivery, release and evaluation procedures all have to be tuned to the dictates of programme needs, and unless this is accomplished through research and development, genetic control methods will not be accepted and used by pest management officials.

Scientists developing genetic control methods for Lepidoptera face particular challenges. It is difficult to economize on rearing methods because of the large size of many species and their susceptibility to disease under mass production conditions. Pupae or adults are rather fragile and cannot easily be stored very long, thus complicating harvesting, packaging, delivery and release. Since many pest Lepidoptera are already managed by cultural, chemical and biological means, there is no ready 'niche' into which SIT can be placed. At present, these and other factors appear to render the classical application of the technique unsuitable for many potential target species.

Much research has focused on developing classical sterile insect release methods, in which fertile populations are 'overflooded' with fully sterile individuals. However, it has been shown that when males are administered a substerilizing dose of radiation, their F_1 progeny are more sterile than the treated P_1 generation and the sex ratio of the F_1 is skewed in favour of male progeny. Such induced-inherited sterility has been observed in a number of species of Lepidoptera: *Heliothis zea* [1], *Galleria mellonella* [2], *Ephestia cautella* [3], *Plodia interpunctella* [4], *Spodoptera frugiperda* [5], *Trichoplusia ni* [6] and *Lymantria dispar* [7]. This technique offers significant advantages over classical sterile release methods. Reducing the radiation dosage minimizes somatic damage, which potentially increases the competitiveness of released individuals. F_1 progeny resulting from matings of released males with fertile females are sterile and exert additional suppressive effects on reproduction. Thus, reproduction is suppressed in at least two generations with only one release. The advantages of this strategy have been discussed at length by Knipling [8] and Snow [9]. Clearly, the F_1 sterility mechanism provides a means for economizing on the use of SIT by reducing rearing and release costs without compromising effectiveness. Such refinements enhance the usefulness of the sterile insect method of control relative to conventional management technology.

As mentioned earlier, inherited sterility has been observed in a large number of Lepidoptera, which are generally considered to be radioresistant. It is believed that F_1 sterility can be induced in all species of that order [10]. Important contributions to the advance of this technology have been provided by the work of Carpenter et al. [11, 12] in laboratory studies with *H. zea*. Inherited deleterious effects were observed for several generations and, through simulation modelling,

Knipling [13] and Carpenter et al. [5] predicted that males treated with a dose of 10 krad¹ and released at a 9:1 ratio into a wild population would reduce reproduction by greater than 99% after three generations. Theoretically, a similar ratio of 100% sterile males would have a maximum effect of 90% reduction. These results imply great potential for inherited sterility as a strategy for management of *H. zea*.

Field testing of this principle has been limited. Proverbs et al. [14] reported that the release of partially sterile codling moth males reduced wild populations by approximately 59%, compared with a release of fully sterilized moths, which resulted in a 38% reduction. Tests by Charmillot [15], utilizing a lower radiation dose (10 krad) resulted in suppression of the native population. Importantly, field collection of the F₁ showed a high level of sterility, demonstrating that sterility was carried into successive generations under field conditions.

Inherited sterility in Lepidoptera was reviewed at length by North [16] and he cited important field cage studies with the cabbage looper, *Trichoplusia ni* [17], and the sugarcane borer, *Diatraea saccharalis* [18], but pointed out that no major trials have been conducted under field conditions. In separate trials, irradiated (25 krad) male and female corn earworms, *H. zea*, were released on St. Croix, the United States Virgin Islands. Larvae that were subsequently sampled had chromosome aberrations, indicating that they were the progeny of an irradiated parent [19], an important contribution showing that the F₁ were established in the native population.

These studies represent progress in developing inherited sterility technology, and in some cases are crucial to the realization of the operational use of SIT for managing important lepidopterous pests. In the remainder of this paper, we will summarize laboratory and field data concerning this technology for the management of gypsy moth, *Lymantria dispar*. This species is a major pest of hardwoods in North America and it and other members of the Lymantriidae family are important forest defoliators around the world. The gypsy moth is ideally suited for suppression using inherited sterility in that it is univoltine, females usually mate only once and produce an egg mass which may contain over 1000 eggs and, most importantly, it diapauses in the egg stage as an embryo. This feature presents an opportunity for producing F₁ egg masses in the laboratory and stockpiling them for subsequent release. This scenario avoids the significant logistical difficulties of releasing moths.

The possibility of using SIT for control of the gypsy moth was recognized early. However, the development of improved techniques for mass rearing the gypsy moth stimulated a re-evaluation of the technique and a programme of developing SIT for management of this pest was initiated [20]. Laboratory irradiation studies indicated that 8–11 day old male pupae could be completely sterilized with a 15 krad treatment. Behavioural studies confirmed that sterile adults were competitive with wild type individuals in flight behaviour, pheromone response, mating propensity and other characteristics [21–23].

¹ 1 rad = 1.00 × 10⁻² Gy.

An isolated infestation of gypsy moth in Benton Harbor, Michigan, USA, was selected for field evaluation of the technique. Procedures for shipping and releasing sterile pupae were developed and releases of 15 krad treated pupae were conducted over two years. Sterile:fertile male overflooding ratios and female mating success were monitored throughout the project and the infestation was successfully eradicated. Observed results consistently agreed with those expected [24–26]. This pilot project demonstrated the effectiveness of the technique for the eradication of isolated populations.

On the other hand, the trial also pointed out difficulties in the operational use of the technique. Male pupae weigh c. 0.5 g and are somewhat fragile. Special packing and shipping provisions had to be arranged to minimize damage during transit from the rearing facility to the field site c. 1300 km away. Sterile insects were released as pupae in eclosion cages designed to exclude predators, but allow for the exit of emerged moths. Releasing pupae by 'broadcasting' them over the area was considered, but was rejected because of the potential loss due to ground inhabiting predators (ants, small mammals). The eclosion cages were costly and difficult to maintain. Also, to compensate for the relatively short distances that males tend to fly, cages needed to be spaced every 50 m. Finally, since adult males are relatively short-lived (two to three days in the field), frequent releases were necessary to maintain the desired overflooding ratios with the target population. While none of these problems were considered insurmountable in conducting releases in small areas, they did point out that large scale programmes were not economically and logistically feasible with current technology, and that even small programmes would be costly.

Earlier studies had shown that male moths treated as pupae with 10 krad and mated with normal females resulted in egg masses with suppressed hatch (c. 50%). The survival rate of hatching F_1 larvae reared on oak foliage in an insectary was 49% less than wild insects, but developmental time from hatch to pupation was nearly normal [27]. Male F_1 adults mated with females, but were nearly totally sterile. Thus, the option of releasing 10 krad treated males, which would result in a high degree of sterility in the following generation, was presented. Unfortunately, while this scenario was attractive from an economic perspective (two generations of control with one year of release), and we demonstrated its utility in a successful eradication programme [28], the logistical aspects of handling and releasing pupae were still burdensome.

In 1980, we initiated a study to define the effects of radiation dose and male age at treatment on sterility in subsequent generations. Briefly, male pupae in six age groups were exposed to seven different doses of radiation (a total of 42 treatment groups and controls) and then mated with untreated females (50 pairs/treatment group). The F_1 progeny of these matings were evaluated at the egg, larval, pupal and adult stages. The F_1 which survived to the adult stage were out-crossed with untreated adults and in-crossed within their treatment group. The resulting F_2 eggs, larvae, pupae and adults were evaluated and the adults were again out-crossed with normal insects and in-crossed within their own treatment group. All treatments were

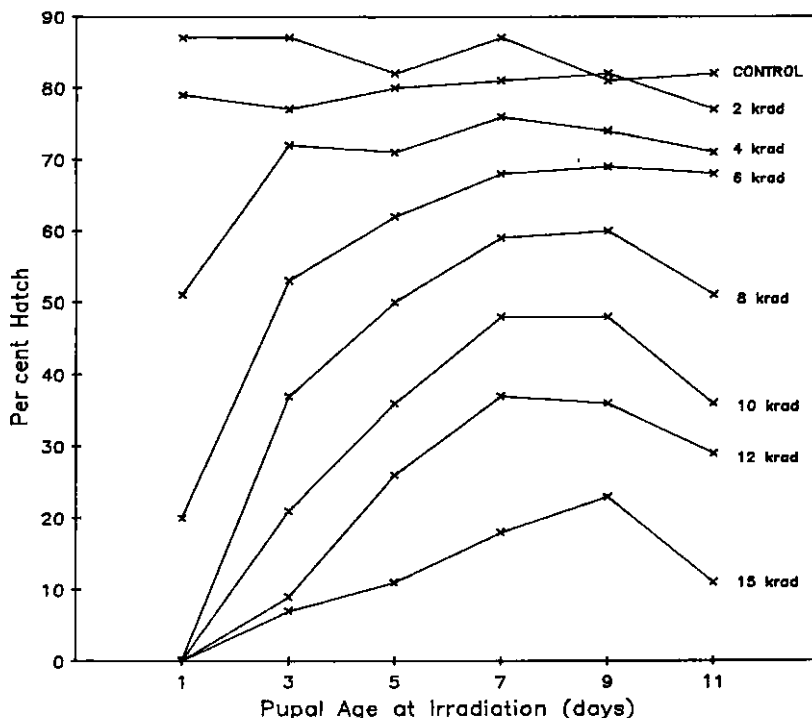

FIG. 1. Per cent hatch of F_1 egg masses which resulted from mating males (treated at varying ages with varying doses of radiation) with untreated females.

evaluated through the F_3 egg stage and selected treatments were studied through the F_4 egg stage. Data on all life stages through the F_3 generation have been compiled and analysed [7]. Because of the large extent of this study, only data from selected treatments will be presented in this paper.

Figure 1 presents the F_1 egg hatch data from all of the treatment groups. Generally, when treated males are mated with normal females, higher doses of radiation result in lower percentages of F_1 eggs which hatch. Also, the younger the male pupae when irradiated, the lower the percentage hatch. Although the data are not presented here, debilitating effects of irradiation were noted in the youngest age class (0-1 day after pupation) treated with a dose as low as 4 krad, (i.e. only 22 of 50 pairs mated). These effects were not observed in the next older age class (2-3 days old) until the treatment dose was increased to 10 krad. The relationship between age of treatment and hatch (e.g. the older the pupae, the higher the percentage hatch or vice versa) appears to be consistent except for the oldest treatment age class (10-11 day old pupae) in which the percentage egg hatch is lower than the next younger age class (8-9 day old pupae).

Figure 2 presents survival and development times for F_1 larvae from the different treatment groups. Generally, survival of neonates from all treatment groups

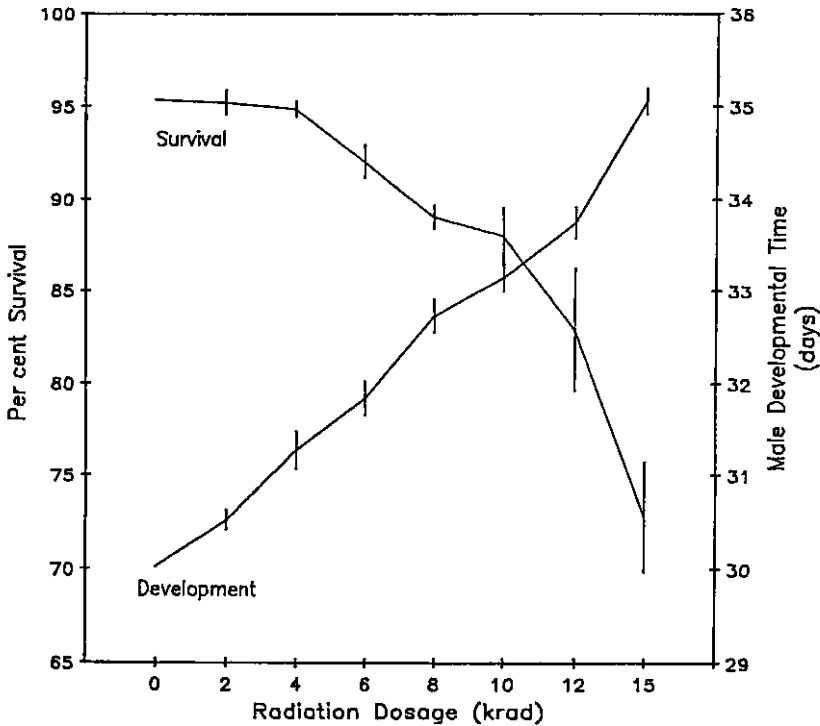

FIG. 2. Survival and developmental times of F_1 larvae that hatched from egg masses produced by untreated females mated with irradiated males. Data presented are means for all age classes at each dosage.

was high (73% for a 15 krad treatment). The proportion of F_1 larvae which survived to the adult stage decreased as the radiation dose increased. Survival was relatively constant between age classes within the same dose. Length of larval development in the F_1 generation also generally increased as the dose rate increased. For example, the mean development time for male progeny of P_1 males treated at 2 krad was 30.5 days, compared with a mean development time of 35.1 days for male progeny treated at 15 krad. Males whose parents received no radiation treatment (control) required an average of 30.0 days for larval development.

Egg mass data from out-crossing and in-crossing F_1 adults for some selected treatments are presented in Table I (all possible mating combinations were made). Because individual matings were not observed and mating could not be confirmed, only those F_2 egg masses with embryonated eggs were included in the summary. Generally, the proportion of these 'non-productive' F_1 pairs also increased as the radiation dose was increased. Whether this indicates that the F_1 did not mate, or mated without oviposition or fertilization, remains to be determined.

Marked effects of radiation on F_1 fertility (i.e. F_2 egg mass viability) were observed in treatment groups receiving doses as low as 4 krad. The data presented

in Table I demonstrate that when F_1 males were out-crossed with control females, the resulting egg masses contained lower proportions of embryonated eggs; and smaller proportions of these eggs hatched than for control matings. The reciprocal mating type (F_1 females \times control males) usually resulted in egg masses in which embryonation was high but hatch was reduced.

When comparing a particular mating type (e.g. F_1 male \times C female) between radiation treatments, the sterility of the F_1 progeny generally increased with the radiation dose administered to the P_1 male parent. In other words, the F_1 progeny of a 10 krad treated male were more sterile than the progeny of a 4 krad treated male. Also, the mating was more fertile when F_1 females were out-crossed than when an F_1 male was out-crossed.

When considering an age versus dose treatment for a particular objective (e.g. eradication instead of population suppression), the fertility of the F_1 female and the survival of any of her F_2 progeny should be closely scrutinized. Selection of a lower treatment dose (6 krad) provides a greater number of F_1 adults. However, those adults are more fertile than F_1 progeny of males receiving higher radiation treatments. Approximately 68% of the eggs in F_1 egg masses hatched when males were treated at 6 krad as 9 and 11 day old pupae (Fig. 1). The progeny of these males survived nearly as well as control insects and development times were shorter than for progeny of males treated at 10 krad, perhaps indicating that they are of a better quality (Fig. 2). The hatch rates of F_2 egg masses produced by either in-crossing or out-crossing the 6 krad treated F_1 adult progeny were greater than for F_1 progeny of a 10 krad treatment (Table I). Although 6 krad may not be considered as a suitable treatment dose when the objective is eradication, it may be a better choice for population suppression. Simulation modelling is essential to predict accurately the consequences of various treatment and release options.

Survival and developmental characteristics of F_2 progeny from various P_1 treatment groups are summarized in Table II. Survival of F_2 progeny from the 6 krad treatment groups was nearly the same as for normal insects; and the length of development of both males and females was more like the control group than for progeny from treatment groups which received higher doses. However, F_2 data from radiation treatments above 6 krad are sketchy because F_1 sterility is high and few F_2 neonates were available for rearing.

Treating P_1 males with 10 krad in either the 8–9 days or 10–11 days age groups provides F_1 progeny which are very sterile (see Table I). However, survival rates of the F_1 progeny are lower than for control larvae, and F_1 mean larval development times are approximately three days longer than normal. The small number of F_2 larvae resulting from out-crossing F_1 adults (either male or female) have longer development times and smaller proportions survive to the adult stage when compared with normal insects (Table II).

The effects of radiation on fertility are apparently carried into at least the F_2 adult stage. Because the data set becomes more complex in each successive generation, the remainder of this discussion will be limited to the characteristics of families

TABLE I. VIABILITY AND SIZE OF F₂ EGG MASSES RESULTING FROM IN-CROSSING (WITHIN TREATMENT GROUPS) AND OUT-CROSSING F₁ ADULTS (PROGENY OF AN IRRADIATED MALE AND AN UNTREATED FEMALE)

Dose (krad)	Treatment of P ₁		Mating type $\sigma \times \varphi$	No. of successful mating pairs (n = 25)	Mean No. of total eggs produced	Mean percentage of eggs embryonated	Mean percentage of embryonated eggs which hatched	Mean percentage of total eggs which hatched
	Age (d)							
6	8-9	F ₁ × C	24	809.5	43.9	15.9	6.5	
		C × F ₁	21	747.5	74.7	20.1	13.0	
		F ₁ × F ₁	20	572.2	44.1	2.3	1.3	
6	10-11	F ₁ × C	21	673.0	46.1	21.1	13.0	
		C × F ₁	26	823.3	77.2	14.8	13.6	
		F ₁ × F ₁	24	659.4	31.8	2.9	1.2	
8	8-9	F ₁ × C	21	612.4	22.1	4.2	1.2	
		C × F ₁	25	735.0	79.6	5.7	5.5	
		F ₁ × F ₁	12	495.2	13.6	0.0	0.0	

8	10-11	$F_1 \times C$	19	625.5	23.5	8.2	1.9	
		$C \times F_1$	22	920.4	79.3	5.7	4.5	
		$F_1 \times F_1$	18	505.4	13.7	0.6	0.1	
10	8-9	$F_1 \times C$	17	607.0	39.8	11.0	7.4	
		$C \times F_1$	25	661.4	74.1	0.5	0.5	
		$F_1 \times F_1$	20	548.6	9.7	0.4	0.1	
10	10-11	$F_1 \times C$	19	460.1	16.8	0.3	0.1	
		$C \times F_1$	22	622.8	66.8	3.1	0.9	
		$F_1 \times F_1$	16	584.3	10.9	0.3	0.1	
<i>Control</i>		$C \times C$	145	947.3	93.7	80.9	76.5	
			(n = 150)					

TABLE II. SURVIVAL AND DEVELOPMENT OF F₂ LARVAL PROGENY OF IN-CROSSED AND OUT-CROSSED F₁ ADULTS FROM FAMILIES IN WHICH P₁ MALES IN TWO AGE CLASSES WERE IRRADIATED AT VARIOUS DOSES

Treatment of P ₁	Mating type of F ₁ parent	No. of neonates infested	Percentage of survival	No. of male pupae	Mean male larval development time (d)	No. of female pupae	Mean female larval development time (d)	Sex ratio (M:F)
6	8-9	216	59.7	63	29.5	66	32.6	0.95
		244	60.7	73	29.8	75	32.7	0.97
		9	88.9	3	35.0	5	38.8	0.60
6	10-11	264	75.8	115	30.2	85	32.8	1.35
		260	70.4	113	30.6	70	32.0	1.61
		52	76.9	20	29.7	20	32.4	1.00
8	8-9	18	55.6	2	32.0	8	37.2	0.25
		74	68.9	26	29.5	25	33.9	1.04
		None ^a	—	—	—	—	—	—

8	10-11	$F_1 \times C$	26	53.9	6	34.4	8	35.9	0.75
		$C \times F_1$	77	71.4	31	30.5	24	34.1	1.29
		$F_1 \times F_1$	None ^a	—	—	—	—	—	—
10	8-9	$F_1 \times C$	136	60.3	54	30.0	28	34.6	1.93
		$C \times F_1$	6	33.3	1	34.0	1	38.0	1.00
		$F_1 \times F_1$	None ^a	—	—	—	—	—	—
10	10-11	$F_1 \times C$	None ^a	—	—	—	—	—	—
		$C \times F_1$	10	40.0	3	30.5	1	32.0	3.00
		$F_1 \times F_1$	None ^a	—	—	—	—	—	—
<i>Control group</i>			3118	76.6	1382	28.6	1007	30.5	1.37

^a Treatments where no F_2 neonates were available for rearing.

in which 8–11 day old P_1 male pupae were treated with 6 krad. Egg masses produced by out-crossing F_2 adults had embryonation slightly less than controls and lower proportions of eggs which hatched. (Table III). Viability was generally the lowest in egg masses produced by in-crossing F_2 adults (mating types 3, 6 and 9). The proportion of eggs which were embryonated and which hatched was also generally the smallest in these same groups. The lowest viability was usually in egg masses produced by in-breeding progeny of irradiated males for two generations (mating type 9), although data here are limited. These effects were found in treatment groups when a dose of as little as 2 krad was used to treat the P_1 male parent (data not shown).

Survival and development of F_3 progeny, regardless of the parentage, appear to approximate the control group better than the F_2 generation (Table IV). The proportions of neonates surviving to the pupal stage for nearly all treatment groups were similar to control insects. Male and female development times, however, appear to be longer than those of control insects. This disparity is not as great as in the F_2 generation. Although the radiation effects are not as pronounced in the F_3 larval stage, they still are apparent. The results of in-crossing and out-crossing F_3 adults (now being evaluated) will determine if inherited sterility effects can be detected in the adult stage.

More than a hundred years after its introduction into North America, the gypsy moth is generally limited in distribution to the north-eastern portion of the United States of America (12 states) and portions of four Canadian provinces. To minimize artificial spread of the insect in the USA, the generally infested area is quarantined. Despite these quarantine measures, infestations of gypsy moths are often detected outside the generally infested area through the use of an extensive detection survey system based on pheromone baited traps (i.e. c. 250 000 traps placed annually) [29]. Eradication programmes have been conducted to prevent permanent establishment of these isolated infestations. These programmes, in the past, have generally been based on chemical insecticides. More recently, biological pesticides, sometimes used in concert with mass trapping techniques, are being employed. Often these transported infestations are associated with household moves and the infestation is located in a residential area. Because of the environmental, social and, in some cases, economic pressures, an alternative tool was needed to effect elimination of these infestations. It was in this arena that we initially began using F_1 sterility for gypsy moth management. The nature of these isolated populations make them well suited for treatment using SIT. In most cases they are detected when population levels are very low and, hence, are easily overflooded with sterile insects. Also, because of the residential nature of many of these sites, a species specific technique that does not produce either a real or perceived environmental hazard would also be more acceptable.

As previously pointed out, even though theoretical models clearly show that the greatest suppressive effect results from the release of partially sterilized adults, the logistics of conducting such an adult release programme on a large scale are formidable. Accordingly, we are introducing the concept of releasing sterile insects in the

egg stage as a means of simplifying field operations. Since F_1 eggs (progeny of 10 krad treated male \times normal female crosses) can be easily reared in the laboratory and held for months in diapause in cool storage, large numbers can be stockpiled. For treatment of an infestation, these egg masses are broadcast into target populations prior to the time of native egg hatch. Provided F_1 and native eggs hatch in synchrony and larval survival and development are comparable with the wild population, the resulting adult overflooding ratios should correlate with the F_1 :native egg mass ratios. Thus, the schedule of field deployment of sterile insects is reduced from daily over the entire flight period (usually c. 30 days) to once, prior to hatch. This approach overcomes a major impediment to the utilization of SIT in gypsy moth management.

To date, eight isolated gypsy moth infestations have been treated using releases of F_1 eggs whose male parents were irradiated (10 krad). Details of the treatment of one of these infestations are presented here. The programme, in Bellingham, Washington, was initiated first, and offers the most complete available information on the impact of an F_1 egg release. The infestation was detected in a residential area in 1983 through the use of pheromone ((+) disparlure) baited traps. More intensive trapping in 1984 succeeded in delimiting the boundaries of the infestation and capturing more male moths ($n = 82$). Also, egg masses and other evidence of a reproducing population were found (i.e. larval and pupal skins).

Because successful application of SIT for any species is so dependent on establishing adequately high sterile:fertile overflooding ratios, reasonably accurate estimates of the native population density are essential. Estimates of gypsy moth populations at the low densities encountered in isolated populations have been shown to be inaccurate using sampling techniques which work well at high insect densities [30]. However, studies have demonstrated a relationship between the proportion of males captured and the actual male density [31, 32]. Approximately 20% of the adult males present in Bellingham during the 1984 season should have been captured at the trap densities used, resulting in a population estimate of 400 adult males. Furthermore, to arrive at an estimate of the overwintering egg mass density, we assumed that there was a 1:1 adult sex ratio during the 1984 flight period and that all females mated and produced viable egg masses that survived until the spring of 1985. In other words, we assumed that there was a spring egg mass population of 400. Although we did not have data from the site on which to base the assumption of a 1:1 sex ratio, and Campbell [33] has shown that skewed sex ratios occur in sparse populations, we assumed that the residential nature of the area and the abundance of man-made objects would foster female larval and pupal survival [34]. At worst, we believed our native egg mass estimate would be too large and we would err only in overflooding at a higher rate than theoretically necessary.

The desirability of establishing as high an overflooding ratio as possible had to be balanced against other factors when establishing the release rate for treatment of this population. Because we would be releasing at a feeding stage in a residential area with limited numbers of ornamental and dooryard fruit trees, we did not want to

TABLE III. SIZE AND VIABILITY OF F₃ EGG MASSES RESULTING FROM IN-CROSSING (WITHIN TREATMENT GROUPS) AND OUT-CROSSING F₂ ADULTS FROM FAMILIES IN WHICH P₁ MALES IN TWO AGE CLASSES WERE TREATED AT 6 krad

Dose (krad)	Treatment of P ₁		F ₁ parents ♂ × ♀	Mating type F ₂ parents ♂ × ♀	Mating type code	No. of mating pairs (n = 25)	Mean No. of total eggs produced	Mean percentage of eggs embryonated	Mean percentage of embryonated eggs which hatched	Mean percentage of total eggs which hatched
	Age (d)									
6	8-9		F ₁ × C	F ₂ × C	1	15	897.9	72.1	47.1	36.3
				C × F ₂	2	15	873.7	79.4	56.4	44.6
				F ₂ × F ₂	3	11	626.6	70.3	26.5	20.6
			C × F ₁	F ₂ × C	4	19	897.9	72.6	43.4	30.6
				C × F ₂	5	14	798.0	82.2	41.8	34.7
				F ₂ × F ₂	6	11	866.5	64.3	15.4	11.6
			F ₁ × F ₁	Data not available						

TABLE IV. SURVIVAL AND DEVELOPMENT OF F₃ LARVAE FROM FAMILIES IN WHICH P₁ MALES IN TWO AGE CLASSES WERE TREATED AT 6 krad

Dose (krad)	Treatment of P ₁ Age (d)	Mating type ^a of F ₁ parent	No. of neonates infested	Percentage of survival	No. of male pupae	Mean male larval development time (d)	No. of female pupae	Mean female larval development time (d)	Sex ratio (M:F)
6	8-9	1	390	71.3	170	28.7	108	30.0	1.57
		2	397	83.1	156	27.3	174	29.8	0.90
		3	194	69.1	86	29.8	48	34.3	1.79
		4	448	76.3	176	27.8	166	31.2	1.06
		5	388	74.0	146	28.9	141	31.9	1.04
		6	134	71.6	39	27.9	57	32.2	0.68

6	10-11	1	410	57.6	152	27.8	84	31.4	1.81
		2	397	81.4	201	28.7	122	32.3	1.65
		3	246	68.3	93	28.9	75	32.8	1.24
		4	342	84.8	162	27.9	128	32.0	1.27
		5	232	90.5	130	27.9	80	30.6	1.63
		6	196	84.7	73	28.9	93	32.4	0.78
		7	208	75.0	88	29.2	68	34.7	1.29
		8	61	91.8	29	29.5	27	31.1	1.07
		9	69	82.6	31	31.5	26	32.7	1.19
<i>Control</i>		C x C	3032	84.4	1501	27.2	1058	29.9	1.42

* See Table V for description of mating types.

release numbers which would produce objectionable defoliation [15]. Our approach was to circumvent this problem by releasing numbers which would provide the desired overflooding ratios and produce the desired outcome, eradication, over a two year period. After surveying the release area for numbers and size of host trees, a release of 34 000 F_1 egg masses was selected for the first year, which we calculated was equivalent to 13 600 'wild' egg masses (wild egg mass equivalents, or WEME) in terms of the numbers of adult males produced. The factors that are included to compute the WEME are number of eggs per mass, reduced F_1 egg hatch, a skewed 2:1 sex ratio and reduced F_1 larval survival. The egg mass distribution in 1985 was weighted to factor in the location and size of host trees. On the basis of all of these assumptions, this 1985 release density should, theoretically, have produced a 34:1 F_1 sterile male:wild male overflooding ratio. Based on the preliminary results of the initial release, an additional 12 769 egg masses (5108 WEME) were released in the spring of 1986, which should have produced an overflooding ratio high enough to effect eradication. The distribution of egg masses in 1986 was also weighted toward areas where sampling in 1985 had located wild insects.

Monitoring the impact of the release over the two year period was carried out using a variety of techniques. To monitor and compare the proportions and synchrony of F_1 and wild egg mass hatch, samples were held in a cage, within the release area which was designed to prevent escape, but which provided normal ambient temperature conditions. The hatching of neonates from individual egg masses was generally monitored daily. Theoretically, successful establishment and survival of F_1 neonates would be reduced if the hatch of F_1 was out of synchrony with host development [35]. However, Montgomery found that differences in foliage maturation of some hosts in the first few weeks after bud break may have minor impacts on neonate survival and establishment [36]. At the least, a precocious or delayed hatch of F_1 eggs could place the F_1 adults out of synchrony with the wilds, thus affecting the potential overflooding ratio. Montgomery also found that adult eclosion overlapped if neonate larvae established within one week of native hatch, but not if hatch was delayed by two weeks.

Daily random samples of larvae and pupae were collected throughout the release area to provide material for monitoring developmental synchrony, survival and overflooding ratios. Collected larvae were placed individually in 1.5 oz (42.5 g) cups provisioned with a diet [37] and held in the laboratory until the type (i.e. F_1 sterile or wild) could be determined. The type of male larvae was determined using two techniques: chromosome analysis and mating-egg mass evaluation.

A portion of the male larvae collected as first through fourth instars was dissected and the testes removed. Dissections were carried out when the greatest numbers of sperm cells were undergoing the first meiotic division. We found this period to occur from four days after the third/fourth larval ecdysis to one day after the fourth/fifth larval ecdysis (insects were held at 25°C and 50–60% relative humidity (RH)). The contents of the testes were 'teased' from the peritoneal sheath into a drop of saline on a glass slide. A drop of orcein stain was added to the spermatocytes and

TABLE V. CHARACTERISTICS OF EGG MASSES PRODUCED BY IN-CROSSING AND OUT-CROSSING F_1 ADULT GYPSY MOTH PROGENY OF MALES IRRADIATED AS 6-11 DAY OLD PUPAE AT 10 krad AND MATED WITH NORMAL FEMALES

Type	Mating type (male \times female)	n ^a	Mean proportion of eggs embryonated	SE	Mean proportion of total eggs which hatched	SE
1	$F_1 \times F_1$	50	0.0910	0.0155	0.0012	0.0006
2	$F_1 \times$ Normal	52	0.2630	0.0380	0.0277	0.0104
3	Normal $\times F_1$	60	0.6711	0.0353	0.0088	0.0020
4	Normal \times Normal	145	0.9374	0.0118	0.7653	0.0154

^a Number of mating pairs producing an egg mass.

a cover slip was placed on the slide and squashed firmly. After allowing time for the cells to stain, the contents were examined using a phase contrast microscope at 400X. The type was determined by scoring early metaphase cells for the number of normal pairs of chromosomes (normally 31 pairs) and the presence or absence of translocations. Our observations generally agreed with those of Rule et al. [38], except that we found meiotic activity in the early fifth instars.

The fertility of the second group of male larvae (approximately one half of all larvae collected as first through fourth instars and all fifth instar and male pupae) was determined by using a mating-egg mass evaluation technique. One day old adult males (the day after eclosion) were mated to similarly aged, virgin, laboratory reared females. The resulting egg masses were held for 30 days (25°C, 50%–60% RH) for embryonation and type determinations were based on the proportion of eggs which were embryonated. The proportion of embryonated eggs in each mass was compared using Chi-square techniques with mean values for mating types 1 and 2 (Table V) [39].

As with the second group of males, all field collected female larvae and pupae were held until adult eclosion and mated as one day old insects with normal laboratory males. The resulting egg masses, however, were held for the normal 30 day embryonation period and an additional 150 days (at 4–5°C) to satisfy diapause requirements. A determination of the female type was then based on the percentage hatch of the eggs. As with the male samples, the characteristics of each egg mass were compared statistically with the mean values for per cent hatch for mating types 3 and 4 (Table V). Holding egg masses produced by females of unknown type is necessary because F_1 females, when mated with normal males, produce highly embryonated egg masses which are often indistinguishable from egg masses produced by normal mating pairs.

The sterile F_1 :fertile wild male mating ratios were monitored by placing one day old, virgin F_1 females in small mating houses throughout the release area. In unpublished studies we found that normal laboratory reared and F_1 females attract and mate with wild males with the same periodicity and frequency as wild females (collected as pupae). This is in contrast to studies by Richerson [40] employing laboratory reared and wild females. Egg masses oviposited by these females were evaluated for male parental type based on the proportion of eggs which were embryonated (Table V).

After the adult flight season was over the egg masses from the release area were collected and evaluated for mating type. Evaluations were based on the proportions of embryonated eggs and the hatch of total eggs (Table V). Potentially, these field collected egg masses could be the progeny of all four possible mating types.

A 23.3 km² area centred over the release area was trapped throughout the adult flight period with United States Department of Agriculture (USDA) high capacity, milk carton, pheromone baited traps during both years of treatment. Traps were placed on a grid at a rate of 13.9 traps/km². Trapping information was used to determine if the treated area was adequately isolated from other infested areas, and also to provide estimates of the total male adult density during the two treatment years.

The egg hatch from samples of wild type and F_1 egg masses during the spring of 1985 was nearly synchronous (Fig. 3). Wild egg masses were not available for monitoring in 1986, but samples of F_1 egg masses appeared to hatch in good synchrony with foliage development of host trees. We believe that the synchrony of hatch, with the availability of suitable host foliage, is important. Data from another study, not reported here, showed diminished larval populations and adult overflooding ratios when F_1 egg hatch was delayed. Wild egg masses in 1985 produced a mean of 279 neonates per mass, while F_1 egg masses produced a mean of 162 neonates.

Evaluation of male larval samples in 1985 produced overflooding ratios close to those expected. Of the 538 male larvae that were typed using chromosome analysis, 448 were typed as F_1 and eight as wilds. These data provide an estimate of the male larval F_1 :wild ratio (first through fourth instars) of c. 57:1. Because of various factors, no determination of type could be made on the remaining 72 male dissections. F_1 larval establishment and survival studies on host foliage have shown that most of the F_1 mortality occurs in the early stadia. Therefore, a better estimate of the eventual adult overflooding ratio would be based only on determinations of later instars. In this study, if only those insects collected as late instars are considered, the F_1 :wild overflooding ratio would be approximately 32:1 (254 F_1 and eight wilds).

In all, 693 field collected male samples were reared with the adult stage and mated with normal laboratory reared females for determination of type. Evaluation of the resulting egg masses disclosed that the male parents of 677 of these samples were sterile F_1 and 11 were fertile wilds. In five cases, the proportion of embryonation was statistically not different (at the 5% level) from the mean proportions of

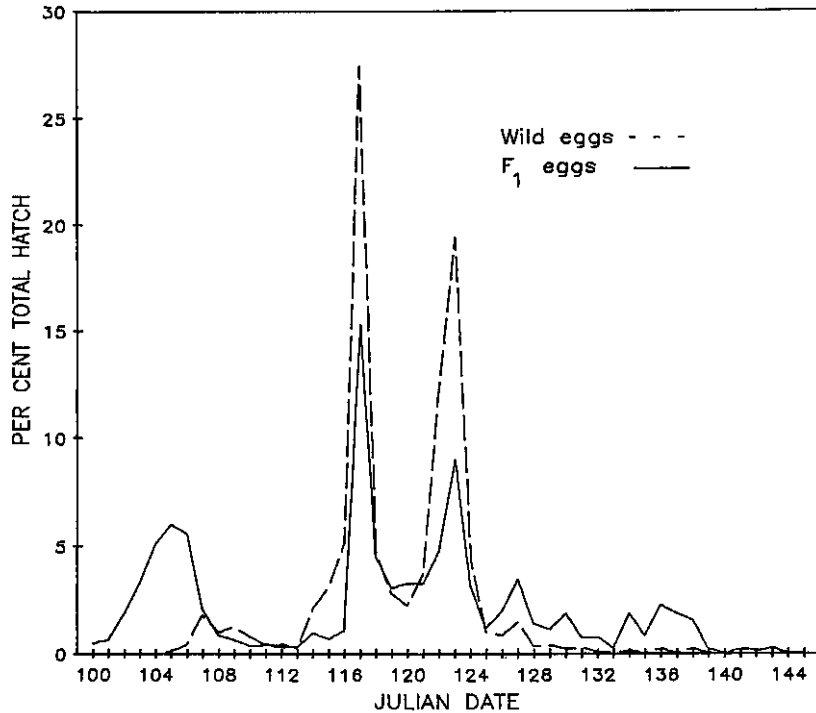

FIG. 3. Egg hatch from samples of wild ($n = 9$) and F_1 ($n = 27$) egg masses at Bellingham, Washington, 1985.

embryonated eggs for either mating type. The overflooding ratio calculated from egg mass evaluations was c. 62:1.

If only collections of late instar larvae are considered, the estimate of the overflooding ratio is c. 80 F_1 :1 wild ($n=483$). Wild male larvae were found to be widely scattered throughout the release area, indicating that the native population distribution was well represented by trap captures the previous year.

The results from sampling and evaluating female larvae and pupae in the release site are consistent with the results of male evaluations. Of the 372 field collected females reared to the adult stage and paired with normal laboratory reared males, 309 produced egg masses which could be evaluated. Females producing egg masses characteristic of a fertile male \times F_1 female mating totalled 241, while nine females produced egg masses characteristic of a fertile \times fertile mating. Of the remainder, 49 egg masses contained all unembryonated eggs (i.e. probably did not mate) and 12 females produced egg masses with characteristics which could not be distinguished (at the 5% level of significance) from the mean values of the two possible mating types. Computing a female overflooding ratio from these data results in an approximately 27 F_1 :1 wild ratio. Theoretically, the F_1 :wild female ratio in the field should be approximately one half of the male ratio because F_1 egg masses produce adults

in a skewed 2:1 male to female ratio. The observed overall female F_1 :wild ratio in 1985 of 27:1 was approximately half of the observed male ratios arrived at by chromosome analysis (57:1) and mating-egg mass evaluation (62:1).

In 1985, monitoring the adult male mating ratio by placing F_1 females in mating houses produced 93 egg masses which could definitely be characterized as being the result of a mating with an F_1 male ($n = 88$) or a wild type male ($n = 5$). The calculated overflowing F_1 :wild ratio is 17.6:1. The remaining 734 egg masses could not be characterized because they contained all unembryonated eggs. Unembryonated egg masses can be the result of an F_1 male mating or no mating. Undoubtedly, some of these 734 egg masses were the result of an F_1 male mating, but it is impossible to separate these. Unfortunately, in 1985 it was not noted when the monitor females had begun to oviposit. In unpublished studies we have determined that mated females begin to oviposit, soon after mating, generally within an hour, while unmated females generally do not begin to oviposit until they are three days old or older. In 1986, in an attempt to separate females producing unembryonated egg masses into mated and unmated categories, we noted if oviposition had commenced when the female was retrieved and if not, how soon afterward.

After the adult flight period, 63 egg masses were collected from within the release area. These egg masses could potentially be the progeny of all four mating types: matings of types 1 and 2 (i.e. those types involving an F_1 male parent) cannot be separated from each other, either by comparing the proportion of eggs which are embryonated or the proportion which hatch. However, types 3 and 4 can be separated from each other and from types 1 and 2. Of the 63 egg masses collected, one was determined to be from a type 4 (fertile male \times fertile female) mating. Seven egg masses had characteristics of type 3 matings and 36 were evaluated as being the progeny of pairs with an F_1 male parent (i.e. type 1 or 2). In 19 of these cases, the female parent was determined to be an F_1 . Computing mating ratios from the above data provided the following. Sterile:fertile *male* ratio 5.1:1 ($n = 43$) and sterile:fertile *female* ratio 26:1 ($n = 27$). This female ratio agrees with the ratio arrived at from larval collection. However, the male ratio is much lower than the predicted ratios or the ratio determined by larval sampling or placing monitor females. The low F_1 :wild ratio indicated by evaluation of these egg masses collected in the post-season is unexplained. We are, however, exploring various possible reasons for this outcome. Overall, the ratio of sterile egg masses (where at least one parent was an F_1) to fertile egg masses (both parents fertile wilds) was 62:1.

Male trapping in 1985 captured a total of 869 males and 745 of these were captured in the release area. For the most part, the remaining males were captured within 536 m of the release site.

During the 1986 larval and pupal sampling periods, it was only possible to collect a small number of immature insects ($n = 93$). Of these, 29 males could be evaluated. Five of these were dissected for chromosome analysis and all were typed as F_1 . The remaining males were reared to the adult stage and mated with normal females. Twenty-four produced egg masses characteristic of an F_1 male parent and

1 produced an egg mass characteristic of a wild male parent. On the basis of all of the males, the F_1 :wild ratio in 1986 was calculated to be 29:1.

In 1986, twenty-six field collected immature females were reared to the adult stage. Mating of these females with normal laboratory males resulted in 14 egg masses on which a determination could be made. Thirteen of these egg masses were evaluated to be from F_1 females and one was evaluated to be from a wild female.

As in 1985, monitor F_1 females were placed daily throughout the release area. Sixty-seven of these females produced egg masses determined to be the result of an F_1 male mating and an additional 49 females producing unembryonated egg masses had begun to oviposit by the time of recovery (the evening of the day the female was placed). At the time of recovery, these females were one day old and we concluded that these females had mated with fertile males. No monitor females produced an egg mass which could be characterized as the result of mating with a fertile male. Characteristics of one egg mass could not be separated statistically from either mating type.

Trapping in 1986 resulted in 209 males being captured within the core area, or c. 28% of the males captured in the same area in 1985 ($n = 745$). This roughly corresponds to the reduced F_1 release in 1986 (c. 35% of the 1985 release). In all, 244 males were captured within the 23.3 km² area.

On the basis of the 1986 results, no further release was made in 1987. Trapping in 1987 was carried out at the same trap density as in previous years, but the high capacity milk carton trap was replaced by the more efficient USDA delta trap. No males were trapped in 1987.

A summary of the monitoring of this release site is presented in Table VI. Generally, the sterile F_1 :fertile wild male ratios observed were near the expected 34:1 overflooding ratio in 1985. The observed ratios from male chromosome analysis (57:1) and male mating-egg mass evaluation (62:1) are not different at the 5% level of significance (Chi-square analysis). Also, ratios calculated from reduced data sets (i.e. using only later stage insects for chromosome analysis) (32:1) and mating-egg mass evaluation (80:1) are not significantly different from ratios derived from their parental data sets or from each other. Both of the overall male ratios computed from larval sampling are significantly different (at the 5% level) as compared with the ratio computed using monitor female egg mass analysis (17.6:1) and post-season egg mass evaluation (5.1:1). The ratios derived from these two evaluation techniques are also significantly different (at the 5% level) from each other.

At the beginning of the 1986 field season, an estimate of the residual wild population was needed to determine the number of F_1 egg masses to be released to achieve eradication. From trapping data we estimated that the 869 males trapped represented 9.1% of the total male population (i.e. 9549). Only three estimates of male overflooding ratios in 1985 were available at the time of the 1986 egg release (i.e. male chromosome and mating-egg mass evaluations and monitor female-egg mass evaluation). On the basis of these F_1 :wild ratios (ranging from 17.6:1 to 79.5:1), we calculated that the wild male population could have been between 119 and 513 males (i.e. 1.24 to 5.38% of 9549 males). Again, we made the assumption

TABLE VI. EXPECTED AND OBSERVED RESULTS OF RELEASING F_1 PROGENY OF 10 krad IRRADIATED MALES IN AN ISOLATED GYPSY MOTH POPULATION IN BELLINGHAM, WASHINGTON

Method of estimation	Year			
	1984	1985	1986	1987
Expected spring wild egg mass density	—	400	8	0
Numbers of F_1 released (WEME)	0	13 600	5108	0
Expected F_1 :wild male ratio (range)		34:1	640:1 (189:1 to 22 554:1)	
Observed F_1 :wild male ratios				
(1) Chromosome analysis				
(a) All instars		57.3:1	5:0	
(b) Later instars		31.8:1		
(2) Mating-egg mass evaluation				
(a) All samples		61.5:1	24:1	—
(b) Later instar and pupae		79.5:1		
(3) Monitor female mating ratio		17.6:1	116:0	—
(4) Evaluation of post-season egg masses				
Male ratio		5.1:1	No data	—
Overall ratio		(62:1)		
Observed F_1 :wild female ratios				
(1) Mating-egg mass		27:1	13:1	—
(2) Evaluation of post-season egg masses:				
Female ratio		26:1	No data	—
No. of males trapped	82	869	244	0
Estimated male population	400	9549	2681	0

of a 1:1 sex ratio in the wild population and that F_1 males were completely competitive. The number of successful wild mating pairs in 1985 was calculated to be 2 to 27, respectively, for estimates of F_1 :wild mating ratios of 17.6:1 and 79.5:1. We believed that the estimated mating ratio of 17.6:1 provided by monitor female data was too low for previously mentioned reasons and that the true mating ratio was nearer 34:1 or higher. When the appropriate calculations are made using a 34:1 F_1 :wild male ratio, wild egg density in the spring of 1986 is estimated at eight wild egg masses. We released 5108 F_1 WEME which, if the wild egg mass population in the spring of 1986 consisted of eight egg masses, would provide a male overflooding ratio in the order of 640 F_1 :wild males.

Sampling in 1986 was successful only in collecting a small number of immature insects. Based on all males collected as immatures and typed (both techniques), the

actual male ratio was lower, 29 F₁:1 wild. Monitor female data indicated a much higher male overflooding rate (116:1). It was mentioned earlier that in 1986 egg mass release was concentrated at known sites of wild insects. Hence, samples were concentrated around these same sites because immatures were difficult to locate. Monitor females, however, were distributed as in 1985 (i.e. generally throughout the area). Therefore, a ratio based on the assessment of immature males could be biased toward the wilds, while monitor female data may provide a better estimate of the ratio throughout the release area.

On a preliminary basis, we conclude that the F₁ egg mass release in Bellingham was successful in eradicating the native population. However, another year of negative trap survey data is necessary in order to confirm this outcome using our own criteria. The evidence of successful interaction with, and suppression of, the native population is apparent. Clearly, we need to develop better techniques for estimating native egg mass densities and correlating results of the different monitoring techniques with the actual ratios in the field.

As data from other sites are being collected and analysed, we are generating more information about the accuracy and utility of these techniques. The results from this and the other sites have also posed problems which must be dealt with: how to predict when native hatch will occur and how to time F₁ egg mass release so that the hatch is synchronous; what is the impact of dispersal (neonate and adult) on the overflooding ratios, etc. In addition, this programme has emphasized the need to develop techniques for evaluating competitiveness of immatures, an area not dealt with properly in SIT literature.

We believe that the F₁ technique is at present operationally useful for treating isolated gypsy moth infestations. Furthermore, we believe that the technique may be useful for the management of gypsy moth populations within the generally infested area. This possibility becomes more attractive when considering those F₁ that are the progeny of males receiving lower (6 or 8 krad) doses of radiation. Finally, all of the investigations associated with the technique have led to a better understanding of the biology and behaviour of the insect.

REFERENCES

- [1] NORTH, D.T., HOLT, G.G., *Manitoba Entomol.* 4 (1970) 53.
- [2] NIELSEN, R.A., United States Department of Agriculture Technical Bulletin No. 1539, USDA, Washington, DC (1976).
- [3] AHMED, M.S.H., et al., "Exploratory studies on the possibility of integrated control of the fig moth, *Ephesia cautella* Walk.", Application of Induced Sterility for Control of Lepidopterous Populations (Proc. Panel Vienna, 1970), IAEA, Vienna (1971) 1.
- [4] COGBURN, R.R., TILTON, E.W., BURKHOLDER, W.E., *J. Econ. Entomol.* 59 (1966) 682.
- [5] CARPENTER, J.E., et al., *J. Econ. Entomol.* 76 (1983) 378.
- [6] NORTH, D.T., *Radiat. Res.* 31 (1967) 615.
- [7] MASTRO, V.C., Otis Methods Development Center Rep., Otis Air National Guard Base, MA (1983) 46.

- [8] KNIPLING, E.F., United States Department of Agriculture Handbook No. 512, USDA, Washington, DC (1979).
- [9] SNOW, J.W., et al., *J. Econ. Entomol.* **65** (1972) 906.
- [10] LACHANCE, L.E., Rep. ARS-28, United States Department of Agriculture, Washington, DC (1985).
- [11] CARPENTER, J.E., et al., *J. Econ. Entomol.* **79** (1986) 47.
- [12] CARPENTER, J.E., et al., *J. Econ. Entomol.* **80** (1987) 483.
- [13] KNIPLING, E.F., *Bioscience* **20** (1970) 465.
- [14] PROVERBS, M.D., et al., *Can. Entomol.* **110** (1978) 1095.
- [15] CHARMILLOT, P.J., *Bull. Soc. Entomol. Suisse* **50** (1977) 203.
- [16] NORTH, D.T., *Annu. Rev. Entomol.* **20** (1975) 167.
- [17] TOBA, H.H., et al., *J. Econ. Entomol.* **65** (1972) 409.
- [18] WALKER, D.W., et al., *J. Econ. Entomol.* **64** (1971) 660.
- [19] NORTH, D.T., et al., *J. Econ. Entomol.* **68** (1975) 595.
- [20] MASTRO, V.C., et al., in *The Gypsy Moth: Research Toward Integrated Pest Management*, United States Department of Agriculture Technical Bulletin No. 1584, USDA, Washington, DC (1981) 669.
- [21] MASTRO, V.C., *J. N.Y. Entomol. Soc.* **88** (1980) 60.
- [22] WALDVOGEL, M., et al., *Environ. Entomol.* **11** (1982) 351.
- [23] MASTRO, V.C., Otis Methods Development Center Rep., Otis Air National Guard Base, MA (1978) 60.
- [24] MASTRO, V.C., Otis Methods Development Center Rep., Otis Air National Guard Base, MA (1980) 132.
- [25] MASTRO, V.C., Otis Methods Development Center Rep., Otis Air National Guard Base, MA (1981) 139.
- [26] MASTRO, V.C., Otis Methods Development Center Rep., Otis Air National Guard Base, MA (1982) 70.
- [27] LANCE, D.R. et al., Otis Methods Development Center Rep., Otis Air National Guard Base, MA (1984) 55.
- [28] MASTRO, V.C., ODELL, T.M., Otis Methods Development Center Rep., Otis Air National Guard Base, MA (1983) 95.
- [29] SCHWALBE, C.P., in *The Gypsy Moth: Research Toward Integrated Pest Management*, United States Department of Agriculture Technical Bulletin No. 1584, USDA, Washington, DC (1981) 542.
- [30] WILSON, R.W., Jr., FONTAINE, G.A., United States Department of Agriculture Handbook No. 523, USDA, Washington, DC (1987) 97.
- [31] SCHWALBE, C.P., PASZEK, E.C., Otis Methods Devevelopment Center Rep., Otis Air National Guard Base, MA (1978).
- [32] ELKINGTON, J.S., et al., *Environ. Entomol.* **9** (1980) 729.
- [33] CAMPBELL, R.W., *Science* **13** (1976) 19.
- [34] CAMPBELL, R.W., et al., *Environ. Entomol.* **5** (1976) 273.
- [35] HOUGH, J.A., PIMENTAL, D., *Environ. Entomol.* **7** (1978) 97.
- [36] MONTGOMERY, M., personal communication, 1987.
- [37] BELL, R.A., et al., in *The Gypsy Moth: Research Toward Integrated Pest Management*, United States Department of Agriculture Technical Bulletin No. 1584, USDA, Washington, DC (1981) 542.
- [38] RULE, H.D., et al., *J. Insect Physiol.* **11** (1965) 369.
- [39] MASTRO, V.C., et al., Otis Methods Development Center Rep., Otis Air National Guard Base, MA (1984) 49.
- [40] RICHERSON, J.V., *J. Econ. Ent.* **69** (1976) 621.

Invited Paper

A GENETIC PERSPECTIVE ON PEST CONTROL AND THE FUTURE OF AUTOCIDAL CONTROL

M.J. WHITTEN

Division of Entomology,
Commonwealth Scientific and Industrial
Research Organization,
Black Mountain,
Canberra, ACT,
Australia

Abstract

A GENETIC PERSPECTIVE ON PEST CONTROL AND THE FUTURE OF AUTOCIDAL CONTROL.

The benefits and limitations of chemical methods of pest control are acknowledged and the need to find alternatives is recognized at the outset. Genetic methods of control that specifically aim to reduce pest abundance by altering the genetic makeup of individuals in field populations are viewed as one important alternative or adjunct approach to chemical control. There is a tendency to classify methods of pest control according to the predominant discipline involved in the development of the technology. This basis for classification can divert attention from the essentially genetic dimensions of control measures, such as pesticides, synthetic sex pheromones, sterile insect techniques and genetic manipulation, whether by classical cytogenetic methods or recombinant-DNA procedures. By way of contrast, cytoplasmic incompatibility, traditionally viewed as a genetic approach because such phenomena are usually studied by geneticists, is probably more a host/parasite phenomenon. The paper attempts to apply a genetic perspective to the diverse array of control measures currently used by pest managers. It strives to indicate how one can benefit from applying such a genetic perspective to manipulating pest abundance, in terms of initial effectiveness, and the likely genetic response, in the form of resistance, over the longer term. More specifically, the paper examines the prevailing concepts of genetic control of insect pests and whether these have any legitimate claim to becoming practical tools for controlling major insect pests. A serious limitation to the development of genetic methods of pest control has been the absence of sustained genetic studies on important pest species, such as the Mediterranean fruit fly (medfly) and other pests from the Diptera, Coleoptera and Lepidoptera orders. The application of classical cytogenetic and modern molecular biology techniques offers considerable promise in improving sterile insect techniques and for developing genuinely novel methods of autocidal control. However, these newer techniques are unlikely to realize their full potential if they are not developed hand-in-hand with the more traditional techniques of physiology, biochemistry, behaviour and ecology. The commercial ramifications of some of the newer techniques are beginning to hinder rapid and complete exchange of experimental results and technical advances in this exciting field.

INTRODUCTION

The control of insect pests by genetic means was first conceived by Serebrovksii and colleagues in the 1930s, but the initiative was terminated for reasons outlined in Ref. [7]. Genetic control as a practical means of pest management was independently developed by Knipling and colleagues in the USA and first successfully implemented during the 1960s with the sterile insect technique (SIT) programme for the screwworm fly. However, the US workers were applied entomologists and they did not particularly regard SIT as a genetic method of control.

It was in between these two significant events in the historical development of genetic control that synthetic pesticides, or neurotoxins, became the major means of insect pest control and have remained so until today. This being so, can we relax our efforts in seeking to widen the applicability of genetic methods of pest control?

Four factors have increased the urgency for the development of alternatives to chemical methods of pest control. These factors are: rapid and widespread genetic change within the target pest populations giving rise to resistance; increased costs of developing and registering new pesticides; greater consumer awareness of pesticide residues in foodstuffs; and the enactment of legislation in many countries to minimize residues or prohibit the use of broad spectrum chemicals. For example, some 90% by volume of herbicides currently used in the USA are deployed in contravention of the Federal Food, Drug and Cosmetics (FDC) Act of 1954, and some 30% of insecticides should be deregistered by the Environmental Protection Agency because of possible oncogenic effects [1]. In balance, then, modern man is losing the battle to control insect and other pests through the release into the environment of chemical toxins; and the long term prospects are not sanguine. Thus the need is greater than ever for pest managers to find other means of controlling insect pests with less reliance on chemical toxins. In this context, biological and autocidal control techniques assume an increasing importance in man's pursuit of alternative pest management strategies. While no one is likely to suggest that genetic methods of control are applicable to a wide range of insect pests, the spectacular success in controlling the screwworm fly in North America fully justifies further investigation of the sterile insect technology and other autocidal control methods for major insect pests.

A GENERAL GENETIC BASIS FOR PEST CONTROL

Before we address directly the various genetic options for autocidal control per se, it may be useful for us to identify the array of pest management approaches which contain a genetic

dimension and to consider the likelihood of a genetic response by the target pest which might reduce or remove the effectiveness of the technique. Pesticides, synthetic pheromones and autocidal control, whether by induced or inherited sterility, all have one thing in common: they increase the incidence of individuals in the treated population whose genetic makeup renders them incapable of surviving in the prevailing environment, and the population 'crashes'. In other words, these approaches aim to remove the natural balance or harmony between the range of genotypes existing in a particular population, and the array of environments in which these individuals normally develop and propagate.

In any natural population of insects undisturbed by man's intervention, there will invariably be a small proportion of individuals whose genetic composition makes them unlikely to survive to maturity or reproduce across a range of likely environments. Conversely, varying proportions of individuals from different populations will experience environmental circumstances during development which prevent survival of particular genotypes, or which prevent survival regardless of genotype. This naturally occurring proportion of 'unsuccessful' individuals, whose condition is caused by a disharmony between genotype and environment, represents the background genetic load we witness in any typical field population. Clearly this background genetic load is usually insufficient in 'untreated' populations of a pest species to contain its numbers, and the resulting abundance exceeds some nuisance threshold, prompting retaliatory action by man.

THE GENETIC BASIS OF CHEMICAL CONTROL AND PESTICIDE RESISTANCE

The most likely retaliatory action by man, especially since the 1940s with the widespread availability of synthetic chemical toxins, has been, effectively, to create an instant and artificial disharmony between genotype and environment by shifting the environment such that the vast majority of individuals now find themselves developing in a contrived environment for which their genetic makeup is inadequate for development and reproduction. Thus, chemical control can be construed as having its effect by increasing the rate of genetic death in the target population; we can regard it as an environmentally induced genetic load. The attractions of chemical control are that it can be highly effective in reducing abundance, the effect on numbers can be sustained where persistent chemicals are employed and it can be highly cost-effective. Furthermore, a single broad spectrum chemical can be used with equal effectiveness, to induce the same environment shift and create disharmony between genotype and environment, across a range of unrelated pest species. The

toxic environment for the target pest is usually short-lived. Repeated applications are necessary and thus chemical control techniques are commercially attractive to the large chemical manufacturers, and a preferred option to many pest managers.

However, chemical control does have one serious drawback; the technique is not novel in nature. It has been used by organisms over evolutionary time to provide them with an escape from their natural enemies, or from some hostile environment. For example, many plants have exploited secondary chemicals to deter potential herbivores, and similarly some animals have developed their own toxic compounds, or borrowed lethal chemicals from their host plants to protect themselves from predators or parasites. Consequently, many organisms have responded to attempts by their host to generate the disharmony between genotype and environment, by selecting genes which confer protection through metabolic resistance [2, 3]. Accordingly, such organisms might be regarded as being pre-adapted to cope with control strategies which depend on environmental modification by the use of toxic chemicals. Interestingly, control strategies which employ manipulation of physical parameters in the environment, such as those sometimes used for controlling stored grain pests, e.g. with high or low temperatures or by varying the composition of rather basic and invariant chemicals such as N_2 , CO_2 or O_2 , are less likely to evoke a genetic response resulting in resistance. Experiences with grain storage techniques using these latter approaches are not normally associated with resistance, whereas resistance to chemical toxins in stored grain pests is quite common [4]. Biological control, by the release of natural enemies, can also lead to a genetic shift in the target pest, but, unlike the synthetic pesticide, the natural enemy itself is capable of responding to natural selection, thereby retaining some capacity to track its host as the latter develops strategies to avoid the controlling influence of the natural enemy.

Viewing chemical control of insect pests from a genetic perspective can assist us in two ways. Firstly, it provides us with a conceptual framework for characterizing the underlying genetic, biochemical and molecular basis for the observed phenotypic shift from susceptibility to resistance. Secondly, it can help us identify the particular environmental circumstances, produced by residues of the chemical toxin, which favour the resistance genotypes [5]. This is the underlying philosophy behind strategies designed to manage pesticide resistance, since it enables us to focus attention on the selective force which favours the rare resistance genotypes, thereby ensuring their increase in frequency.

In summary, we can reasonably suppose that pest control by the application of chemical toxins produces high genetic loads initially and is quite effective in the short term. However, it

can be regarded as an unsound evolutionary strategy and, accordingly, the case is stronger than ever for seeking more soundly based strategies for controlling pest species.

For related reasons, we might challenge the euphoria of molecular biologists who advocate protecting crop plants and animals against major pests by introducing into their genomes genes which code for toxic proteins. In such cases, we might reasonably suppose the existence of rare genotypes in populations of the target pest which can survive adequately in the new and hostile environment created by the genetic engineer, and which would rapidly displace the originally common, and now inviable, genotype. Natural selection could well negate the efforts by the molecular biologist and undermine the investment in the genetically engineered plant or animal.

PEST CONTROL BY MODIFYING THE GENOTYPE OF THE PEST SPECIES

An alternative means of creating disharmony between genotype and the environment, which could lead to an intolerable genetic load in the target pest, is to seek some means of altering the hereditary material of individuals in treated populations such that few or none are capable of surviving in prevailing environmental circumstances. One way of achieving this objective is to cause the majority of females in a population to produce zygotes incapable of surviving in any possible environment. This approach would include a procedure where the female is inseminated by a male which transfers sperm containing defective genetic material (e.g. males 'sterilized' by irradiation or chemosterilants (SIT), or carrying compound chromosomes or other chromosome rearrangements which result in chromosomal imbalance and dominant lethality), or where the female fails to be inseminated and only lays unfertilized eggs (e.g. mating disruption using synthetic sex pheromones).

Another approach is to introduce genetic material into the population through the release of one or both sexes, which will cause inviability in later generations (e.g. recessive lethals and conditional lethals where particular environmental circumstances are required for lethality). Sometimes both approaches can be combined in the one system, e.g. Y-autosome translocations with sex linked recessive lethals [6]. Unfortunately, most of these approaches require an inundative release of competitive insects that have been maintained and mass produced under artificial conditions for some generations: it is this necessity which imposes a major limitation on the application of genetic control to many pest species. To circumvent the problem, some authors have suggested identifying an appropriate genetic transporting mechanism, such as meiotic drive or negative heterosis (for a review, see Ref. [7]). More

recently, with the discovery of hybrid dysgenesis caused by the 'de-repression' of transposable elements, the idea of developing and releasing infectious genetic diseases has been proposed [8].

In the list of genetic approaches just given, we have included the use of synthetic sex pheromones. It is important to recognize the true genetic nature of pest control by the use of these substances. Although this technique has been used successfully on a commercial scale in only a few instances, (e.g. *Pectinophora gossypiella*, pink bollworm, in California [9] and *Cydia molesta*, oriental fruit moth, in Australia [10]), the approach is likely to be used with increasing frequency over the next two decades. The recent literature suggests that some ecologists have ideological difficulties in accepting the possibility of controlling major insect pests by any genetic means, especially the radiation-induced sterile male technique. However, these same ecologists have no conceptual impediment to accepting pest suppression by mating disruption with sex pheromones because they tend to view this approach as being essentially behavioural or ecological. While genetic control and synthetic sex pheromones use fundamentally different technologies in their development and application, and each has quite different commercial ramifications, in a formal genetic sense both approaches are equivalent - they reduce the likelihood of the female laying eggs which will develop into viable adults under prevailing environmental conditions.

In terms of developing resistance, strategies which employ sex pheromones or SIT could suffer a common fate - the target pest species could resort to asexuality. Clearly this outcome is a possibility, since asexuality is not uncommon amongst insects [11], but it would seem that such an outcome is unlikely.

Another resistance approach open to any pest being controlled by sex pheromones, which is not available for a pest species controlled by SIT or inherited sterility, would be to change its pheromone blend so that the synthetic blend is not recognized by wild type males [10]. A genetic response producing this outcome is clearly possible, if only because sibling species have often changed their pheromone blend in recent evolutionary time [12, 13], but it would seem less probable because changing the pheromone blend requires two types of genetic response. Firstly, the female must select for a shift in the type or abundance of the pheromone blend she synthesizes and releases, and secondly the male requires a sensory receptor to respond preferentially to the new formulation [14]. Thus a complex genetic response is required in the pest species and this would appear less probable than the relatively simple genetic shift which might be required to handle chemical toxins.

Finally, where the target pest does successfully change its pheromone blend for mate recognition, the applied entomologist should have no difficulty adjusting the synthetic blend to track such a genetic response. Unfortunately, there is no equivalent logical path for the chemist to follow when presented with resistance to chemical toxins.

Haynes et al. [10] list several other possible avenues for resistance to develop to synthetic pheromones. The female could increase the amount of pheromone released, thereby competing more effectively against the synthetic lures. Alternatively, the males could sharpen their discriminatory abilities to distinguish any deficiencies which are likely to exist between the natural and synthetic blends. Together this range of options does argue for caution in suggesting that resistance cannot develop to synthetic pheromones. However, as Haynes et al. [10] indicate, where synthetic blends are only used for a minority of generations of a particular pest in each season, it is difficult to imagine how a pest can adequately cope with this alternation of selection pressures. Indeed, to the extent that a response is evoked during the period of selection pressure with the synthetic pheromone blend, there may be a carry-over genetic load during the period of reverse selection when natural pheromone blends are in vogue. Thus, the use of synthetic sex pheromones can be viewed as an excellent genetic approach to controlling insect pest species where mates are secured through chemical communication.

Thus, in comparing and contrasting chemical and genetic control strategies for insect pests, one common feature is that each exerts its suppressive effect by creating a disharmony between genotype and environment. In the case of chemical control, however, this disharmony generates pressure for a genetic shift to remove it and, if successful, creates resistance and a consequent breakdown in effectiveness of the chemical. With genetic control, however, natural selection is an integral part of the control strategy since we are specifically relying on its action to eliminate the inappropriate genotypes that have been introduced into the target population. Consequently, natural selection creates the genetic load and the suppressing effects which lead to population collapse or eradication. In other words, natural selection is working for us, and not against us, in genetic control strategies. We can therefore conclude that selection of resistance cannot arise in the same way using genetic control, nor indeed with the same high probability, as it has been shown to do with chemical control procedures.

RECENT ADVANCES IN GENETIC CONTROL OF INSECT PESTS

It is generally accepted amongst geneticists that resistance to autocidal methods of control (whether by SIT or inherited sterility) is most improbable. However, it is equally accepted by the geneticist that a major problem with genetic methods of control is devising a practical and commercially viable method in the first place. The balance of this paper deals with recent advances in developing genetic methods of pest control.

Just as we have implied criticism of ecologists for failing to recognize the intrinsic genetic nature of chemical and hormonal control of insect pests, one could be equally critical of some SIT proponents for failing to acknowledge for several decades the essentially genetic nature of the sterile insect technique [7]. However, this view is now widely accepted and perhaps its most salutary consequence has been the recent recognition of the need to establish the formal genetics of major SIT candidates. This trend is clearly demonstrated in this Symposium by the number of papers which use genetic procedures with a view to enhancing SIT, or developing genetic alternatives to SIT, for medfly and other insect pests and which indicate the existence of sound genetic and cytogenetic procedures underpinning the various research programmes discussed.

GENETIC ENHANCEMENT OF THE STERILE INSECT TECHNIQUE

Regrettably, the spectacular success of the screwworm project in North America has few parallels [15]. The reasons for this are many and have been discussed elsewhere [7]. Genetic techniques can aim to increase the efficacy of SIT in two general ways: by increasing its cost-effectiveness, or by removing some of the direct detrimental effects of releasing sterile females. One single genetic device that promises to provide advances on both of these fronts is the use of genetic sexing techniques [16]. It is therefore not surprising to see the recent endeavours in developing practical genetic sexing techniques for the medfly, other fruit flies and various mosquito species. The use of chromosome rearrangements and various conditional lethals is now a widely investigated approach and several speakers in this Symposium are exploring that particular approach. Recombinant-DNA technology provides additional approaches to solving the problem and these are discussed below.

A more comprehensive treatment of the various cytogenetic and molecular biology approaches to solving this problem was considered by an FAO/IAEA Advisory Group in December 1985 [17]. Two key elements to the molecular approach to developing

genetic sexing procedures were recognized as (1) the existence of a general gene transfer technique for transforming insects and (2) the identification, isolation and characterization of DNA segments which code information for inducing maleness or for eliminating females early in development. A more detailed outline of the implications of molecular biology for autocidal control is contained in Ref. [8]. What is abundantly clear is that the full potential of molecular biology and recombinant-DNA technology will not be realized unless and until there exists a comprehensive understanding of the genetics of the pest species. Molecular biology is not an alternative to genetics; the two disciplines are synergistic to each other.

It is only a matter of time before general gene transfer techniques are developed and become widely available to applied entomologists. Considerable effort is being made around the world to find ways of extending the gene transfer techniques using variants of the transposable P-element which is now widely used for transferring genes within the genus *Drosophila* [18]. Other techniques exist in plant and microbial systems, such as electroporation, which might find application in insect systems [19]. No general gene transfer technique suitable for a range of insect pests has yet been published. Because of the possible commercial significance of such technology, it is becoming increasingly difficult to ascertain the true state of development on this subject. No longer is it inevitable that technical breakthroughs are immediately published, and many scientists are finding themselves operating in a research environment where the commercial ramifications of their research precludes rapid publication, or indeed publication at all.

A greater challenge, and one requiring considerably greater effort, arises from the necessity to identify suitable DNA sequences which might be used to eliminate females or to transform females into males under defined conditions of mass-rearing. However, it is heartening to see that molecular biologists, especially *Drosophila* workers, are increasingly interested in the challenge of developing general gene transfer techniques for pest insects and in exploring the genetic basis of sex determination with a view to its application in applied entomology.

One promising approach to identifying segments of DNA whose expression causes the carrier to develop into males is being pursued by J. Martin and B.T.O. Lee at the University of Melbourne. These workers have shown that sex determination in native populations of *Chironomus* sp. is under the control of a specific locus which can be localized to a particular band in polytene chromosomes and which exists on different chromosome arms in different populations [20]. The isolation and cloning of distally located polytene bands known to include the male

determiner gene and subsequent in situ studies have enabled these workers to isolate segments which hybridize specifically to regions known to be sites containing sex determining loci. It is possible that the approach being used by Martin and Lee will demonstrate the existence of sequences of DNA whose expression would cause the development of maleness. If such a sequence exists and is sufficiently conserved, it could be explored as a probe to isolate similar sequences from other Diptera. The coupling of such structural genes with appropriate promoters to permit expression under specifically prescribed conditions of mass rearing could enable the conversion of the final generation of mass reared female zygotes to all develop and emerge as males, with the obvious benefit to many SIT programmes.

One of the virtues of recombinant-DNA technology is the manner in which research conducted on one species can be readily applied to quite unrelated species. For example, the gene coding for the enzyme which controls the first step in the conversion of tryptophan to the brown ommochrome pigment in *D. melanogaster* was isolated by A.J. Howells and colleagues at the Australian National University using the homologous gene derived from rat liver [21]. Similarly, many genes from *D. melanogaster* are being used as probes to isolate related genes from other insect species. Suddenly the fundamental research on *D. melanogaster* and other laboratory 'guinea pigs' has a relevance for insect pests not particularly amenable to laboratory studies or genetic analysis.

ALTERNATIVE GENETIC MEANS OF AUTOCIDAL CONTROL

Many alternative genetic approaches to SIT involve chromosome rearrangements, such as compound chromosomes and translocations, and specific mutations which are lethal under specific environmental conditions [7]. Most of the genetic control schemes contemplated or being actively pursued during the 1970s relied on conventional cytogenetic techniques and classical Mendelian genetics. One such example is the system in which Y-autosome translocations are coupled with conditional lethals, currently being developed and evaluated by G.G. Foster and R.J. Mahon for the Australian sheep blowfly. A series of field trials over the past ten years has demonstrated the effectiveness of this approach to suppression of *Lucilia cuprina* populations [22-25]. The first large commercial scale eradication project on a group of offshore islands covering some 1900 km² is currently under consideration.

Molecular biology techniques can be considered for increasing the impact on target populations of sheep blowfly following the release of genetically manipulated strains. For example, if a gene transfer technique becomes available, it

could be used to transfer wild type alleles of particular conditional lethal genes to the autosomal elements in the Y-autosome translocation systems discussed above. By these means, we could increase the number of conditional lethals built into the strain, thereby increasing the genetic load generated in the target population [8]. Alternatively, if a male determining gene becomes available, we could generate neo-Y chromosomes from any of the autosomes. Such neo-Y chromosomes could then be modified to contain the wild type alleles of conditional lethals, again giving us another type of strain generating a high genetic load. These possibilities are discussed further in Ref. [8].

Despite the widespread enthusiasm during the 1970s for such genetic approaches to pest control, there are very few projects still in train; and regrettably many of the genetic stocks for some of the major pests have now been lost.

CYTOPLASMIC INCOMPATIBILITY AND HYBRID STERILITY

We have already suggested that novel techniques for pest control are usually categorized according to the discipline of those research workers developing and popularizing the technique, e.g. synthetic sex pheromones and SIT. This observation seems particularly true for cytoplasmic incompatibility. The phenomenon itself was often first noted in a particular insect species by a general entomologist, but its more detailed investigation usually entailed collaboration with geneticists, since crossings were invariably conducted. The non-reciprocity of the phenomenon and the application of genetic thinking prompted explanations in terms of self-replicating cytoplasmic particles (i.e. extra-chromosomal) which interacted with nuclear genomic factors, giving rise to unviable progeny when the cross was made in particular directions between individuals from allopatric populations. It is now known that many incompatibilities are caused by microorganisms which are symbionts in both sexes but are only transmitted in the egg cytoplasm. For example, Barr [26] has shown convincingly that a rickettsia-type bacterium, *Wolbachia pipientis*, is responsible for incompatibility between populations of *Culex pipiens*. More recently, *Wolbachia* has been associated with incompatibility in the alfalfa weevil [27], the almond moth [28] and *D. simulans* [29]. It is further known that the causative organism disables the sperm produced in the host male in some manner and that such disabled sperm are only rescued if they fertilize eggs containing the appropriate microorganism [26]. This mechanism gives the microorganism a transmission advantage, enabling it to spread through an affected population [28]. Thus, it may appear that cytoplasmic incompatibility, which is known to exist in a wide

range of insects and which invariably involves rickettsia-type organisms, is not a genetic process at all, but rather a biochemical or immunological device used by symbiotic microorganisms to spread through host populations. Viewed in this context, it is possible to consider inoculation of these microorganisms into pathogen-free populations only as a means of inducing a temporary genetic load or as a transporting mechanism for introducing genetic material into a target population [30].

By way of contrast, the mechanisms underlying hybrid sterility, such as that observed between *Heliothis subflexa* and *H. virescens*, is not understood. It does not appear to involve microorganisms [31] and may be associated with a genuine genetic incompatibility between nuclear and mitochondrial genes, since the sterile hybrid males have abnormal sperm with aberrant mitochondria [32].

THE FUTURE

It is difficult and indeed pretentious to predict the future in an area of scientific endeavour such as genetic control where unique opportunities presented by each pest species must be exploited by the research worker. Our biggest limitation in the past two decades has been the degree of segregation of the various disciplines of ecology, genetic and applied entomology. These disciplines must work closely together, and this is particularly true of molecular biology, if we are to identify genuine alternatives and adjuncts to the more traditional methods of pest control. The limitations with broad spectrum chemical methods which we identified earlier provide every incentive for the exploration of biological and genetic alternatives. The medfly and other fruit flies must represent major targets for such endeavours.

REFERENCES

- [1] CARLSON, C., ROBBINS, G.J., "Regulating pesticides in food - The Delaney paradox" (Committee on Scientific and Regulatory Issues Underlying Pesticide Use Patterns and Agricultural Innovation), Board of Agriculture, US National Research Council, National Academy Press, Washington, DC (1987).
- [2] GEORGHIOU, G.P., "The magnitude of the resistance problem", Pesticide Resistance: Strategies and Tactics for Management, National Academy Press, Washington, DC (1986) 14-43.

- [3] PLAPP, W., Jr., "Genetics and biochemistry of insecticide resistance in arthropods: Prospects for the future, *ibid.*, pp. 64-86.
- [4] EVANS, D.E., "Stored products", Integrated Pest Management (BURN, A.J., COAKER, T.H., JEPSON, P.C., Eds), Academic Press, New York and London (in press).
- [5] WHITTEN, M.J., MCKENZIE, J., "The genetic basis for pesticide resistance" Grassland Invertebrate Ecology (Proc. 3rd Australasian Conf. Adelaide, 1981) (LEE, K.E., Ed.), South Australian Govt Printer, Adelaide (1982) 1-16.
- [6] WHITTEN, M.J., et al., "Current status of genetic control of the Australian sheep blowfly, *Lucilia cuprina* (Wiedemann) (Diptera: Calliphoridae)" (Proc. XV Int. Congr. Entomol. Washington, DC, 1976) (1977) 129-139.
- [7] WHITTEN, M.J., "Conceptual basis for genetic control", Comprehensive Insect Physiology, Biochemistry and Pharmacology (KERKUT, G.A., GILBERT, L.I., Eds), Pergamon Press, Oxford (1985) 465-528.
- [8] COCKBURN, A.F., HOWELLS, A.J., WHITTEN, M.J., Recombinant DNA technology and genetic control of pest insects, *Biotechnol. Genet. Eng. Rev.* 2 (1984) 69-99.
- [9] VICKERS, R.A., ROTHSCHILD, G.H.L., JONES, E.L., Control of the oriental fruit moth, *Cydia molesta* (Busck) (Lepidoptera (Tortricidae), at a district level by mating disruption with synthetic female pheromone, *Bull. Entomol. Res.* 75 (1984) 625-634.
- [10] HAYNES, K.F., GASTON, L.K., MISTROT POPE, M., BAKER, T.C., Potential for evolution of resistance to pheromones: Interindividual and interpopulational variation in chemical communication system of pink bollworm moth, *J. Chem. Ecol.* 10 11 (1984) 1551-1565.
- [11] WHITE, M.J.D., *Animal Cytology and Evaluation*, 3rd edition, Cambridge University Press, London (1973).
- [12] ROELOFS, W.L., BROWN, R.L., Pheromones and evolutionary relationships of Tortricidae. *Annu. Rev. Ecol. Syst.* 13 (1982) 395-422.
- [13] WHITTLE, C.P., BELLAS, T.E., HORAK, M., PINESE, B. The pheromone and taxonomic status of *Homona spargotris* Meyrick sp. rev., an Australian pest species of the coffearia group (Lepidoptera: Tortricidae: Tortricinae), *J. Aust. Entomol. Soc.* 26 (1987) 169-179.
- [14] PATERSON, H.E.H., More evidence against speciation by reinforcement, *S. Afr. J. Sci.* 74 (1978) 369-371.
- [15] LACHANCE, L.E., "Genetic strategies affecting the success and economy of the sterile insect release method", *Genetics in Relation to Insect Management (Working Papers)*, The Rockefeller Foundation, New York (1979).
- [16] WHITTEN, M.J., FOSTER, G.G., Genetic methods of pest control, *Annu. Rev. Entomol.* 20 (1975) 461-476.

- [17] INTERNATIONAL ATOMIC ENERGY AGENCY, Application of Genetic Engineering and Recombinant DNA Technology in the Development of Genetic Sexing Mechanisms for the Mediterranean Fruit Fly, *Ceratitis capitata* (Wied.) (Rep. Consultants Mtg Vienna, 1985), IAEA, Vienna, 1985, 1-18.
- [18] SPRADLING, A.C., "P element mediated transformation", *Drosophila - A Practical Approach* (ROBERTS, D.B., Ed.), IRL Press, Oxford and Washington, DC (1986) 175-197.
- [19] FROMM, M., TAYLOR, L.P., WALBOT, V., Expression of genes transferred into monocot and dicot plant cells by electroporation, *Proc. Natl. Acad. Sci. USA* 82 (1985) 5824-5828.
- [20] MARTIN, J., KUVANGKADILOK, C., PEART, D.H., LEE, B.T.O., Multiple sex determining regions in a group of related *Chironomus* species (Diptera: Chironomidae) *Heredity* 44 (1980) 367-382.
- [21] WALKER, A.R., HOWELLS, A.J., TEARLE, R.G., Cloning and characterization of the vermilion gene of *Drosophila melanogaster*, *Mol. Gen. Genet.* 202 (1986) 102-107.
- [22] FOSTER, G.G., VOGT, W.G., WOODBURN, T.L., Genetic analysis of field trials of sex-linked translocation strains for genetic control of the Australian sheep blowfly *Lucilia cuprina* (Wiedemann), *Aust. J. Biol. Sci.* 38 (1985) 275-293.
- [23] VOGT, W.G., WOODBURN, T.L., FOSTER, G.G., Ecological analysis of field trials conducted to assess the potential of sex-linked translocation strains for genetic control of the Australian sheep blowfly, *Lucilia cuprina* (Wiedemann), *Aust. J. Biol. Sci.* 38 (1985) 259-73.
- [24] MAHON, R.J., WOODBURN, T.L., FOSTER, G.G., Suppression of a field population of the sheep blowfly *Lucilia cuprina* by release of a sex-linked translocation strain (unpublished).
- [25] MAHON, R.J., FOSTER, G.G., Genetic control of the Australian sheep blowfly (unpublished).
- [26] BARR, A.R., "Symbiont control of reproduction in *Culex pipiens*", *Recent Developments in the Genetics of Insect Disease Vectors*, Stipes Publishing Company, Champaign, IL (1982) 153-158.
- [27] HSIAO, C., HSIAO, T.H., Rickettsia as the cause of cytoplasmic incompatibility in the alfalfa weevil, *Hypera postica*, *J. Invert. Pathol.* 45 (1985) 24-246.
- [28] KELLEN, W.R., HOFFMANN, D.F., KWOCK, R.A., *Wolbachia* sp. (Rickettsiales: Rickettsiaceae) a symbiont of the almond moth, *Ephestia cautella*: Ultrastructure and influence on host fertility, *J. Invert. Pathol.* 37 (1985) 273-283.
- [29] HOFFMANN, A.A., TURELLI, M., Cytoplasmic incompatibility in *Drosophila simulans*: Inheritance, distribution and fitness (personal communication).

- [30] CURTIS, C.F., ADAK, T., Population replacement in *Culex fatigans* by means of cytoplasmic incompatibility. 2. Field cage experiments with overlapping generations, WHO Bull. 53 (1974) 107-119.
- [31] LACHANCE L.E., KARPENKO, C.P., Hybrid sterility in *Heliothis subflexa* x injection with antiviral agents, heat shocks, and rearing at extreme temperatures, Ann. Entomol Soc. Am. 76 1 (1983) 104-109.
- [32] LACHANCE L.E., Hybrid Sterility: Eupyrene sperm production and abnormalities in the backcross generations of interspecific hybrids between *Heliothis subflexa* and *H. virescens* (Lepidoptera: Noctuidae), Ann. Entomol. Soc. Am. 77 1 (1984) 93-101.

BIOTECHNOLOGY IN INSECT CONTROL

(Session 2)

Chairman

T.K. MUKIAMA

Kenya

BIOTECHNOLOGIES ET LUTTE CONTRE L'ONCHOCERCOSE

R. LE BERRE

Organisation mondiale de la santé (OMS),
Genève, Suisse

Abstract-Résumé

BIOTECHNOLOGY AND THE FIGHT AGAINST ONCHOCERCIASIS.

Biotechnology has recently broken into the rather closed field of human and animal disease vectors and vector control. With regard to blackflies which carry onchocerciasis, in particular, some possible directions which initial research is taking, and which future research might follow are: identification of vectors among the species making up the *Simulium damnosum* group; identification in the vectors of *Onchocerca volvulus* strains, of greater or lesser pathogenic nature according to the geographical area; identification of the source of the blood meal; and identification of resistance on an individual level. This research will all contribute towards the development of tools for use in the field, which will enable the epidemiology of onchocerciasis to be better understood, and the fight against this form of parasitosis to be better planned. After a long period using chemical insecticides, the discovery of the larvicidal properties of *Bacillus thuringiensis* serovar 14 (*B.t.* H-14), and of *Bacillus sphaericus*, opens up new horizons. However, the formulation of these biological insecticides is not entirely satisfactory, and research is therefore in progress to discover the toxins inside the commensal organisms of certain disease vectors.

BIOTECHNOLOGIES ET LUTTE CONTRE L'ONCHOCERCOSE.

Les biotechnologies ont depuis peu fait leur entrée dans le domaine très clos des vecteurs de maladies humaines et animales et dans la lutte antivectorielle. En ce qui concerne plus particulièrement les simulies vectrices d'onchocercose, voici quelques-unes des directions — on pourrait en imaginer d'autres — dans lesquelles les recherches ont débuté ou sont prévues: identification des vecteurs, au niveau des espèces composant le complexe *Simulium damnosum*; identification, chez leurs vecteurs, des souches d'*Onchocerca volvulus*, plus ou moins pathogènes selon la zone géographique; identification de la source du repas sanguin; identification de la résistance au niveau individuel. L'ensemble de ces recherches contribuera à mettre au point des outils utilisables sur le terrain permettant de mieux comprendre l'épidémiologie de l'onchocercose et de mieux planifier la lutte contre cette parasitose. Après une longue période d'utilisation d'insecticides chimiques, la découverte des capacités larvicides de *Bacillus thuringiensis* sérovar 14 (*B.t.* H-14) et de *Bacillus sphaericus* ouvre de nouveaux horizons. Toutefois, la formulation de ces insecticides d'origine biologique n'est pas entièrement satisfaisante. C'est pourquoi des recherches sont entreprises, qui ont pour but d'exprimer les toxines à l'intérieur d'organismes commensaux de certains vecteurs.

1. INTRODUCTION

L'onchocercose est une maladie parasitaire dont l'agent pathogène, une filaire, *Onchocerca volvulus*, est transmis, selon la zone géographique, par plusieurs espèces de simulies. Cette maladie, dont la principale manifestation est la cécité, constitue

un problème considérable sur les plans sanitaire, social et économique dans les zones de savane d'Afrique où elle est actuellement responsable de la désertion des vallées dans lesquelles se trouvent l'eau — bien entendu — mais aussi les meilleurs sols.

En forêt, malgré une forte prévalence, les manifestations cliniques, et notamment les lésions oculaires, sont beaucoup moins graves, voire inexistantes.

Les vecteurs de l'onchocercose appartiennent tous à la famille des *Simuliidae*, diptères nématocères dont la particularité est de vivre dans l'eau courante à l'état préimaginal. Le plus important d'entre eux, le seul dans une grande partie de l'Afrique centrale et en Afrique occidentale, est *Simulium damnosum*, complexe composé de plus de 10 espèces publiées ainsi que de «formes» non encore décrites.

Six de ces espèces du complexe *S. damnosum* se partagent l'Afrique de l'Ouest: la paire *S. sanctipauli/S. soubrense*, située en forêt où elle se développe dans les grandes rivières; la paire *S. damnosum s.s./S. sirbanum* peuple la savane; *S. yahense* est localisée aux petites rivières de forêt; *S. squamosum* est constituée de populations relativement isolées, peuplant certaines petites rivières, au faciès particulier, de la savane. Curieusement, et sans qu'on ait encore bien compris le phénomène, cette espèce, à l'est du Nigéria (Cameroun, Congo, Zaïre), se développe dans les grands fleuves tels que la Sanaga et le Congo.

2. IDENTIFICATION DES VECTEURS

L'identification du complexe *S. damnosum* a fait l'objet de multiples travaux dans le domaine de la taxonomie fine (Quillévééré et Séchan, 1978; Garms, 1978; Dang et Peterson, 1981; Meredith et al., 1983). La différenciation de certaines espèces a également fait appel à la technique enzymatique (Townson et Meredith, 1979; Meredith et Townson, 1981). C'est toutefois la cytotoxicologie, basée sur l'examen de chromosomes géants des glandes salivaires des larves, qui a donné aux chercheurs — mais aussi aux utilisateurs que sont les responsables de campagnes de lutte — les résultats les plus fiables et les plus complets. Depuis les premiers résultats de Dunbar (1969) et de Dunbar et Vajime (1971), de nombreuses recherches mettant en œuvre cette technique ont été réalisées par Vajime et Dunbar (1975), Vajime et Quillévééré (1978), Quillévééré (1979), Meredith et al. (1983) et Post (1986), l'ensemble des premiers travaux ayant fait l'objet d'une excellente revue par Meredith (1984).

L'épidémiologie de l'onchocercose varie, comme décrite ci-dessus, d'une zone bioclimatique à l'autre. Gravissime en savane, elle perd ses caractères pathologiques en forêt. Cette différence, mise en évidence par Budden dès 1963, a fait l'objet d'hypothèses ayant trait à l'environnement ainsi qu'à l'écologie du vecteur (Le Berre, 1966).

C'est Duke (Duke et al., 1966) qui, le premier, a émis l'hypothèse de l'existence de complexes *Onchocerca-Simulium* spécifiques de chaque zone bioclimatique. Cette ligne de recherche, mettant en œuvre les essais de transmission

croisée parasites de savane-vecteurs forestiers et vice-versa fut poursuivie par Philippon (1977), Quillévéré (1979), Prod'hon et al. (1982). Elle se révéla très fructueuse.

3. IDENTIFICATION DES PARASITES

Si les travaux d'identification des vecteurs furent nombreux, ceux portant sur la séparation des formes d'*O. volvulus*, pouvant réellement rendre compte des différences épidémiologiques observées, n'ont débuté que récemment, si l'on excepte ceux d'Omar (1977), Omar et Garms (1981) et Omar et Schulz-Key (1978), basés sur la méthode histochimique. Des études comparatives mettant en œuvre l'analyse iso-enzymatique ont été entreprises par Cianchi et al. (1985) et par Flockhart et al. (1986). Elles ont permis de mettre en évidence certaines divergences entre les onchocercques récoltées en zone forestière (Côte d'Ivoire, Libéria), en zone de forêt dégradée (Zaire) et en savane (Mali, Burkina Faso, Soudan).

La production d'anticorps monoclonaux spécifiques fait actuellement l'objet de recherches. Celles-ci sont toutefois ralenties par l'approvisionnement en matériel biologique (stade infectant en fin de cycle chez le vecteur). Le développement d'une sonde d'ADN permettant de distinguer la «forme» de savane a été couronné de succès et a fait l'objet d'une publication initiale dans Nature (Erttmann et al., 1987). Les recherches se poursuivent activement dans ces domaines.

4. IDENTIFICATION DES REPAS SANGUINS

Afin de mieux comprendre l'épidémiologie des maladies transmises par vecteurs, il est important de connaître l'origine du sang ingéré par ceux-ci au cours du dernier repas sanguin. Jusqu'à présent, les tests de précipitine ont rendu de grands services aux entomologistes, ceci malgré la lenteur des transports entre les bases de terrain et les centres d'analyses, généralement localisés au Nord.

Afin de pallier cet inconvénient et de donner aux entomologistes un outil pratique, utilisable immédiatement sur le terrain et peu onéreux, l'OMS a mis sur pied un programme visant à comparer plusieurs méthodes: complément de fixation, diffusion double gel, ELISA, ELISA-S, ELISA-I, ELISA-DB, ELISA dipstick-sandwich (DS). Les résultats obtenus peuvent être résumés de la manière suivante:

- le sang humain a été correctement identifié par tous les tests jusqu'à 24 heures après le repas;
- toutes les techniques ont permis de discriminer le sang humain des autres sangs (vache, porc, chèvre, poulet);
- les tests ELISA-DB et ELISA-DS se sont avérés les plus simples car ils peuvent être lus à l'œil nu, dans les heures qui suivent l'essai (Pant et al., 1987).

Ces travaux, préparatoires à la confection de troussees d'essais, se poursuivent. Celles-ci seront probablement disponibles dès 1988.

5. IDENTIFICATION DE LA RESISTANCE AUX INSECTICIDES

La lutte contre l'onchocercose étant, jusqu'à présent, basée exclusivement sur la destruction de ses vecteurs, il est essentiel de connaître, en permanence, le degré de sensibilité de chacune des espèces et des populations aux insecticides utilisés. Compte tenu des conditions très spéciales dans lesquelles se développent les stades aquatiques des simulies, il a été nécessaire de mettre au point une technique d'évaluation particulière à cette famille (Mouchet et al., 1977). Un test a également été développé pour les adultes (Kurtak, comm. pers.). Les techniques biochimiques mises au point pour les moustiques (Pasteur et Georghiou, 1981; Hemingway et al., 1987) pourraient certainement être adaptées aux simulies et utilisées dans les programmes de lutte contre ces insectes.

6. AMELIORATION DES INSECTICIDES D'ORIGINE BIOLOGIQUE

Bien que ne concernant qu'indirectement la lutte contre les simulies, il convient de faire le point, à la fin de cet exposé, des dernières recherches sur les insecticides d'origine biologique que sont le *Bacillus thuringiensis* sérovar H-14 et le *Bacillus sphaericus* dont les cristaux sont hautement toxiques pour les moustiques (les deux) et pour les simulies (*B. thuringiensis* H-14). Ces insecticides ont une haute spécificité mais se recyclent peu — ou pas du tout — dans les gîtes larvaires. Afin de pallier ce défaut qui limite l'utilisation de ces excellents produits, on envisage une association étroite des chercheurs du terrain et du laboratoire. Ceux-là récolteraient, dans les gîtes, les micro-organismes vivant en contact permanent avec les vecteurs, et donc ingérés par eux. Ceux-ci, par manipulation génétique, exprimeraient les gènes toxiques des *Bacillus* dans ces micro-organismes. L'opération, couronnée de succès au laboratoire (Bourgouin et al., 1986), devrait, dans le futur, être introduite sur le terrain avec toutes les précautions nécessaires.

7. CONCLUSION

En conclusion, la recherche sur — et la lutte contre — l'onchocercose et ses vecteurs se poursuivra sur le terrain. Toutefois, les responsables devront continuer à utiliser l'immense potentiel scientifique et opérationnel que représentent les technologies avancées.

BIBLIOGRAPHIE

- BOURGOUIN, C., KLIER, A., RAPOPORT, G., Characterization of the genes encoding the haemolytic toxin and the mosquitocidal delta-endotoxin of *Bacillus thuringiensis israelensis*, Mol. Gen. Genet. 205 (1986) 390.

- BUDDEN, F.H., Comparative study of ocular onchocerciasis in savannah and rain-forest, *Trans. R. Soc. Trop. Med. Hyg.* **57** 1 (1963) 64.
- CIANCHI, R., et al., Preliminary data on the genetic differentiation of *Onchocerca volvulus* in Africa, (Nematoda: Filarioidea), *Acta Tropica* **42** 4 (1985) 341.
- DANG, P.T., PETERSON, B.V., Pictorial keys to the main species and species groups within the *Simulium damnosum* Theobald complex occurring in West Africa (Diptera: Simuliidae), *Trop. Parasitol.* **31** (1981) 117.
- DUKE, B.O.L., LEWIS, D.J., MOORE, P.J., *Onchocerca-Simulium* complexes: 1) Transmission of forest and Sudan-savannah strains of *Onchocerca volvulus* from Cameroon by *Simulium damnosum* from various West African bioclimatic zones, *Ann. Trop. Med. Parasitol.* **60** (1966) 318.
- DUNBAR, R.W., Nine cytological segregates in the *Simulium damnosum* complex (Diptera: Simuliidae), *Bull. Org. Mond. Santé* **40** (1969) 974.
- DUNBAR, R.W., VAJIME, C.G., Etude cytotaxonomique du complexe *Simulium damnosum* WHO/ONCHO/71.87 (1971) 5 p.
- ERTTMANN, K.D., et al., A DNA sequence specific for forest form *Onchocerca volvulus*, *Nature (London)* **327** (1987) 415.
- FLOCKART, H.A., CIBULSKIS, R.E., KARAM, M., ALBIEZ, E.J., *Onchocerca volvulus*: enzyme polymorphism in relation to the differentiation of forest and savannah strains of this parasite, *Trans. R. Soc. Trop. Med. Hyg.* **80** (1986) 285.
- GARMS, R., Use of morphological characters in the study of *Simulium damnosum* s.l. populations in West Africa, *Trop. Parasitol.* **29** (1978) 453.
- HEMINGWAY, J., JAYAWARDENA, K.G.I., WEERASINGHE, I., HERATH, P.R.J., The use of biochemical tests to identify multiple insecticide resistance mechanisms in field-selected populations of *Anopheles subpictus* Grassi (Diptera: Culicidae), *Bull. Entomol. Res.* **77** (1987) 57.
- LE BERRE, R., Contribution à l'étude biologique et écologique de *Simulium damnosum* Theobald (Diptera: Simuliidae), *Mém. ORSTOM* **17** (1966) 204 p.
- MEREDITH, S.E.O., Filariasis: *Simulium*, Needs and Progress in the Application of Biochemical Techniques to the Problem of Vector Identification in New Approaches to the Identification of Parasites and their Vectors, *Tropical Diseases Research Series* **5** (1984) 381.
- MEREDITH, S.E.O., THOMSON, H., Enzymes for species identification in the *Simulium damnosum* complex from West Africa, *Trop. Parasitol.* **32** (1981) 123.
- MEREDITH, S.E.O., CHECKE, R.A., GARMS, R., Variation and distribution of forms of *Simulium soubrense* and *S. sanctipauli* in West Africa, *Ann. Trop. Med. Parasitol.* **77** 6 (1983) 627.
- MOUCHET, J., QUELENNEC, G., BERL, D., SECHAN, Y., GREBAUT, S., Méthodologie pour tester la sensibilité aux insecticides des larves de *Simulium damnosum*, *Cahiers ORSTOM, sér. Ent. méd. et parasitol.* **15** 1 (1977) 55.
- OMAR, M.S., Distribution of acid phosphatase activity in the larval stages of *Wuchereria bancrofti*, *Brugia malayi*, *B. pahangi* and *Dirofilaria immitis* in the mosquito, *Trop. Parasitol.* **28** (1977) 100.
- OMAR, M.S., GARMS, R., Histochemical differentiation of filarial larvae in *Simulium damnosum* s.l. in West Africa, *Trop. Parasitol.* **32** (1981) 259.
- OMAR, M.S., SCHULZ-KEY, H., Acid phosphatase activity in the larval stages of *Onchocerca volvulus* developing in the vector *Simulium damnosum*, *Trop. Parasitol.* **29** (1978) 359.

PANT, C.P., HOUBA, V., ENGERS, H.D., Bloodmeal identification in vectors, *Parasitology Today* (sous presse).

PASTEUR, N., GEORGHIOU, G.P., Filter paper test for rapid determination of phenotypes with high esterase activity in organophosphate resistant mosquitoes, *Mosq. News* 41 (1981) 181.

PHILIPPON, B., Etude de la transmission d'*Onchocerca volvulus* (Leuckart, 1893) (Nematoda: Onchocercidae) par *Simulium damnosum* Theobald (1903) (Diptera: Simuliidae) en Afrique tropicale, *Travaux et documents de l'ORSTOM* 63 (1977) 308 p.

POST, R.J., The cytotaxonomy of *Simulium sanctipauli* and *Simulium soubrense* (Diptera: Simuliidae) *Genetica* 69 (1986) 191.

PROD'HON, J., et al., Influence des migrations humaines ou vectorielles sur la stratégie du Programme de lutte contre l'onchocercose dans la région du bassin de la Volta, *Cah. ORSTOM, sér. Ent. méd. et parasitol.* 20 (1982) 285.

QUILLEVERE, D., Contribution à l'étude des caractéristiques taxonomiques, bio-écologiques et vectorielles des membres du complexe *Simulium damnosum* présents en Côte d'Ivoire, *Travaux et Documents de l'ORSTOM* 109 (1979) 304 p.

QUILLEVERE, D., SECHAN, Y., Morphological identification of females of the *Simulium damnosum* complex in West Africa, differentiation of *Simulium squamosum* and *Simulium yahense*, *Trans. R. Soc. Trop. Med. Hyg.* 72 (1978) 99.

TOWNSON, H., MEREDITH, S.E.O., Problems in the identification of parasites and their vectors: Simuliidae in relation to onchocerciasis, *Symposium of the British Society for Parasitology* 17 (1978) 145.

VAJIME, C.G., DUNBAR, R.W., Chromosomal identification of eight species of the subgenus *Edwardsellum* near and including *Simulium (Edwardsellum) damnosum* Theobald (Diptera: Simuliidae), *Trop. Parasitol.* 26 (1975) 111.

VAJIME, C.G., QUILLEVERE, D., The distribution of the *Simulium damnosum* complex in West Africa with particular reference to the Onchocerciasis Control Programme area, *Trop. Parasitol.* 29 (1978) 473.

INVESTIGATIONS ON SEX LINKED RECESSIVE LETHAL MUTATIONS AS A POSSIBLE MECHANISM FOR THE GENETIC CONTROL OF LEPIDOPTEROUS PESTS

A.I. ANISIMOV

All-Union Institute of Plant Protection,
Leningrad,
Union of Soviet Socialist Republics

Abstract

INVESTIGATIONS ON SEX LINKED RECESSIVE LETHAL MUTATIONS AS A POSSIBLE MECHANISM FOR THE GENETIC CONTROL OF LEPIDOPTEROUS PESTS.

Sex linked recessive lethal mutations (SLRLM) were induced on the Z-chromosome of male codling moths. The competitiveness of a number of strains, each possessing different SLRLM was assessed. The results indicate that a number of strains with SLRLM were isolated and the competitiveness of the heterozygous male carriers was not affected. Methods for combining SLRLM and sex chromosome translocations in the same strain for greater efficiency in the suppression of wild insect populations are discussed.

1. INTRODUCTION

In 1976, Strunnikov [1] proposed the use of strains with balanced recessive lethal mutations on the sex chromosomes for the control of pest insects in which the males are homogametic, such as in Lepidoptera. This idea was developed and used in silkworms to produce only male progeny [2]. At present such strains are in practical use in silkworm breeding stations [3].

When males with two recessive lethal mutations at different gene loci on each sex chromosome are crossed with normal females, all of the female progeny die, except half of those derived from sperm in which crossing-over occurred between the two loci (Fig. 1). Theoretically, if one compares the release of these males into native populations with the release of fully sterile males, the reduction of the native population would only be half as great in the generation following release, but the reduction in the number of females would be equal. In addition, the viable F_1 generation males bearing one lethal mutation on one of the sex chromosomes again cause the death of half of the females in the next generation. In the following generations, sex linked recessive lethal mutations (SLRLM) introduced into the native population's gene pool would continue to suppress the number of pest insects, though with decreasing efficacy. Thus, when comparing a single release of males with balanced SLRLM with that of fully sterile ones, it turns out that in the SLRLM group the population is 1.3, 2.0 and 2.5 times lower in F_2 , F_3 and F_4 , respectively.

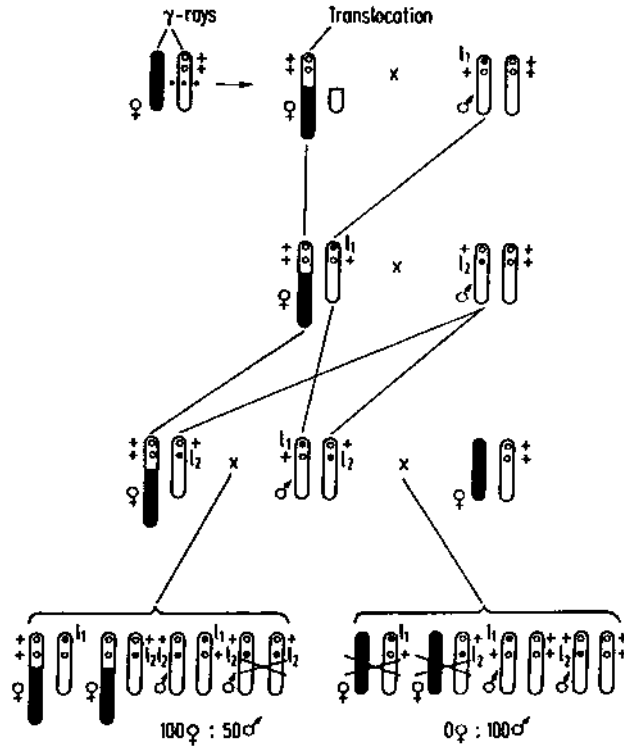

FIG. 1. Construction of silkworm strains balanced by two non-allelic Z-lethals. The W-chromosome is shown by dark colouration. The Z-chromosome and its translocated fragment are shown by light colouration.

Strunnikov further proposed the use of two strains of insects that have SLRLM and chromosome rearrangements [4] (Fig.2). Each strain could be maintained, but when females of strain 1 are crossed with males of strain 2, only male progeny are produced. The males could then be released to mate with native females and no female progeny would be produced and the male progeny would carry SLRLM. This scheme would greatly increase the effectiveness of the releases.

The positive aspects of Strunnikov's ideas mentioned above inspired us to start investigations on the creation of strains balanced by SLRLM in a key pest species of apple orchards, the codling moth. Our results are given in this paper.

2. MATERIALS AND METHODS

Laboratory populations of the codling moth reared on an artificial diet continuously (without diapause) for 11 years were used in these tests. In order to avoid the sterilizing effects of irradiation on the treated parental and F₁ generations, SLRLM

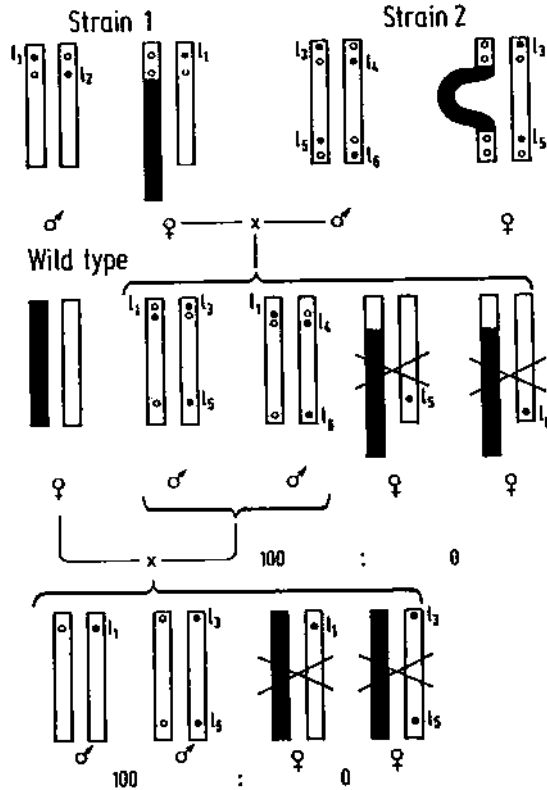

FIG. 2. Construction of two strains of *Lepidoptera* balanced by six non-allelic Z-lethals. The W-chromosome is shown by dark colouration. The Z-chromosome and its translocated fragment are shown by light colouration. Lethal loci are shown as closed circles and the corresponding open circles represent the loci of their normal alleles.

were induced by ethyl methane-sulphonate (EMS), which induces primarily point mutations. Males were treated two to three days after eclosion and paired with untreated females. To isolate SLRLM, the F_1 males were mated individually with one to two females from the laboratory population. The eggs produced by these crosses were examined to determine if a significant number died at the same stage of embryonic development (i.e. stage specific recessive lethals). Lines identified as carrying males heterozygous for SLRLM are maintained by screening the embryonic egg development of each pair.

Figure 3 shows that in the F_1 males, which have descended from an EMS treated male parent and are heterozygous for SLRLM, 50% of the daughters (25% of all progeny) will die and the sex ratio will be 1:2 in favour of males. Half of the sons in the next generation will again be heterozygous for SLRLM and half will be

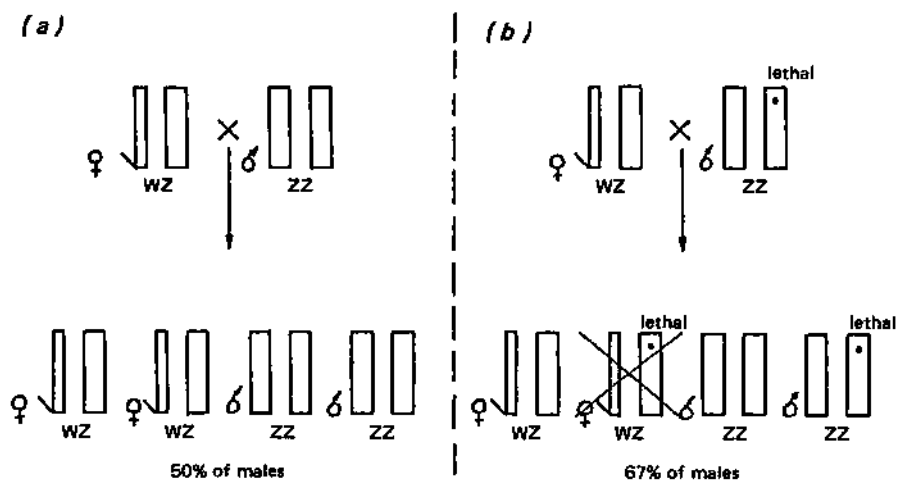

FIG. 3. Isolation of SLRLM. (a) Male without mutations; (b) male with SLRLM.

normal. The ratio of sons with and without SLRLM will be 1:1. These criteria were used to isolate lines carrying SLRLM.

In order to isolate translocations involving the two different sex chromosomes, Z/W females were irradiated with gamma rays one to two days after eclosion and paired with untreated males. F₁ females from an irradiated mother were individually mated with males from a line with SLRLM (Fig. 4(b)).

In these lines (in Fig. 3) there are two types of males which are phenotypically indistinguishable: males heterozygous for SLRLM and normal males. Therefore, in order to maximize the probability of using a heterozygous SLRLM male, we had to mate the same male twice (Fig. 4). Thus, eggs produced by an F₁ female from an irradiated mother (a possible Z/W translocation carrier) and a male from an SLRLM line were examined to see if a significant number died at the same embryonic stage that characterizes the expression of the SLRLM and absence of a Z/W translocation in that line (Fig. 4(a)). When this was observed, the same male was mated with another F₁ female from an unirradiated female parent. Figure 4 shows how the same male is used in the two crosses.

When stage specific lethals appear, then the same male can be mated consecutively with several females until he dies. When the results of matings between several F₁ females (from an irradiated mother) and a male known to be heterozygous for SLRLM are analysed and anomalous results are obtained for a particular F₁ male, this indicates that the female may have a Z/W translocation and the progeny are reared for further study. Thus, when the same male is used and there is a stage specific embryonic death in one cross and not in another, this indicates that a Z/W translocation may be present (Figs 4(a) and 4(b)).

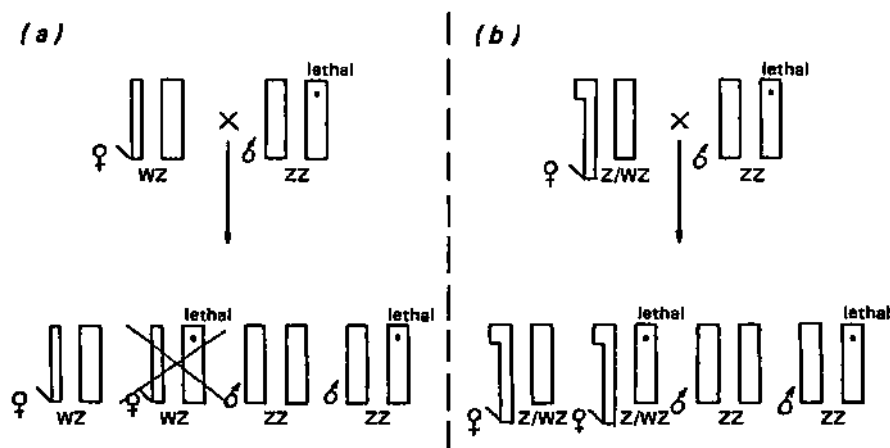

FIG. 4. Isolation of Z/W translocations. (a) Lethal mutation is observed; (b) lethal mutation is not observed.

In another series of experiments we measured the competitiveness of males heterozygous for SLRLM in comparison with normal males. In this study we used a mutant dark strain. 'Dark' is an autosomal recessive that produces a darker pigmentation on several parts of the insect body. It can easily be determined at the adult, pupal and embryonic stages. Competitiveness was assessed when males were from one to four days old and older than four days. The tests were set up as follows. To measure the competitiveness of young males, one male and one female homozygous for dark were caged with one newly emerged male from a line known to carry SLRLM. The two males and one female remained in a Petri dish for three days. The normal coloured male was then removed and crossed with a wild type female to determine the genotype of the male (i.e. whether it had SLRLM or was a normal male). To determine the competitiveness of older males, one newly emerged male from an SLRLM line was crossed with a wild type female and a newly emerged dark male was placed with a dark female for three days. This enabled us to determine the genotype of the wild type male (i.e. whether it had SLRLM or was normal) and also gave both types of males an opportunity to mate and age for three days. Then both males were caged with a virgin dark female for five to six days. In both tests it was necessary to assess if a male from an SLRLM line was normal or carried SLRLM. On the basis of observations of stage specific embryonic deaths plus the sex ratio shift in the progeny, we could easily determine if the male was heterozygous for SLRLM. Non-carriers were then used as controls.

Quantitative assessment of male competitiveness was determined on the basis of the ratio of embryos with dark or normal phenotypes produced by the female. The

coefficient of the competitiveness of wild males relative to dark males was calculated using the following formula:

$$K_c = \frac{\text{number of embryos with normal phenotype}}{\text{total number of developed embryos}}$$

This quantitative estimation permitted us to compare the competitiveness of males with different SLRLM, normal males and dark males. With this method, K_c ranges from 0 to 1 and is equal to 0.5 when two males are equally competitive.

Using the calculated K_c for each of the SLRLM, we can compare each lethal line with the control or with each other by substitution of calculated K_c values in the following equation:

$$K_d = \frac{K_{c1} - K_{c2}}{1 - K_{c2}}$$

where

K_d = competitiveness coefficient of difference between lines (can be a negative or positive value).

K_{c1} = competitiveness coefficient for line 1.

K_{c2} = competitiveness coefficient for line 2.

Comparisons can be made between any two lines, but in this paper all comparisons were made with the control as K_{c2} . K_c values were determined for all lines and the Chi-square criterion was used to test the significance of these differences.

3. RESULTS

Codling moth eggs have a fully transparent chorion. This feature permits us to observe the steps during embryonic development and also to determine when embryonic development ceases in non-hatching eggs. As mentioned earlier, we used stage specific embryonic deaths as the primary method of isolating lines with SLRLM. When F_1 males derived from EMS treated sperm (Fig. 3) were mated with untreated females, most of the eggs produced by the pairs completed embryonic development and hatched (i.e. no SLRLM were induced). In 5-7% of the cases, about 25% of the eggs stopped development at the same stage. When the hatching larvae were reared to the adult stage, and there was a shift in the sex ratio in favour of males, we concluded that half of the male progeny would carry one SLRLM. This was confirmed by further tests involving the males from such a line.

Thus, it was relatively simple to examine the eggs laid by individual pairs ($T\sigma \times N\varphi$) and rear progeny from pairs exhibiting the stage specific embryonic

TABLE I. CHARACTERISTICS OF LINES WITH SLRLM

Conventional SLRLM designation	Characteristics of the heterozygous male progeny		
	LEL level (% \pm SD)	No. of males in progeny (% \pm SD)	No. of males heterozygous for SLRLM (% \pm SD)
L-2	32 \pm 1.1	67 \pm 2.2	45 \pm 6.1
L-3	30 \pm 1.9	66 \pm 1.3	53 \pm 4.3
L-26	27 \pm 1.5	66 \pm 2.9	44 \pm 7.1
L-67	23 \pm 3.2	62 \pm 4.8	56 \pm 7.6
L-106	31 \pm 1.6	67 \pm 1.3	48 \pm 3.4
L-502	27 \pm 3.9	70 \pm 2.4	50 \pm 4.0
<i>Control</i>	3.4 \pm 0.51	51 \pm 0.90	

TABLE II. PROBABILITY OF SLRLM ISOLATION IN THE PROGENY OF F₁ MALES WITH DIFFERENT LEVELS OF LEL

F ₁ LEL levels (%)	F _b families tested			
	Total	Out of which progeny are		
		Normal (% \pm SD)	Complete SLRLM (% \pm SD)	Mosaic SLRLM (% \pm SD)
0-15	20	50 \pm 11.2	10 \pm 2.2	10 \pm 2.2
15.1-30	39	18 \pm 6.2	13 \pm 5.3	15 \pm 5.8
30.1-45	18	44 \pm 11.7	17 \pm 8.8	11 \pm 7.4
>45	4	0 \pm 20.0	75 \pm 21.6	25 \pm 21.6
<i>Total</i>	81	30 \pm 5.1	16 \pm 4.1	14 \pm 3.8

deaths. On the basis of the techniques described above, we isolated a series of lines with SLRLM [1]. Table I contains the characteristics of some of these lines.

A number of studies in the literature indicate that EMS produces mutations by alkylating purines in the DNA. Ethyl methane-sulphonate also produces a number of mosaic mutations [5]. For this reason we could expect to recover a number of mutations that would be of mosaic type.

TABLE III. COMPETITIVENESS OF MALES HETEROZYGOUS FOR SLRLM COMPARED WITH DARK MALES

Conventional SLRLM designation	Age of competing males (d)	No. of males tested	Average competitiveness coefficient (K_c)	No. of males with		Probability of casual deviation from 1:1 ratio
				$K_c < 0.5$	$K_c > 0.5$	
L-3	1-4	29	0.76	7	22	<0.01
	>4	28	0.58	11	17	>0.10
	<i>Total</i>	57	0.67	18	39	<0.01
L-67	1-4	36	0.59	13	23	>0.05
	>4	32	0.69	10	22	<0.05
	<i>Total</i>	68	0.64	23	45	<0.01
L-106	1-4	30	0.64	9	21	<0.05
	>4	29	0.61	9	20	<0.05
	<i>Total</i>	59	0.63	18	41	<0.01
L-109	1-4	27	0.57	11	16	>0.20
	>4	25	0.57	8	17	>0.05
	<i>Total</i>	52	0.57	19	33	>0.05
L-502	1-4	22	0.57	9	13	>0.20
	>4	30	0.64	10	20	>0.05
	<i>Total</i>	52	0.61	19	33	>0.05
<i>Control</i>	1-4	164	0.51	80	80	0.50
	>4	154	0.59	64	90	<0.05
	<i>Total</i>	318	0.55	144	174	>0.10

We conducted a special series of tests that permitted us to correlate a certain frequency of late embryonic lethals (LEL) among the F_1 eggs produced with the results obtained by continued studies of the progeny in each line. In these studies individual F_1 males were pair-mated and the frequency of LEL among the eggs was determined (0-15, 15.1-30, etc.). The progeny were reared and at least six F_2 generation males (sons back-crossed with normal females) from each family were tested. If we failed to find stage specific embryonic deaths, the family was placed in the 'normal' class. It is not unusual to find that LEL can occur owing to damage in handling or other causes that are not inherited. Also, some families from F_1 males that had mosaic SLRLM stabilized after some divisions and these could also be placed in the normal class. Because of the low number of F_2 males tested in each family, a

number of lines with SLRLM could escape detection. Also, because of variations and limitations on the number of males we could test in each family it was very difficult to differentiate many of the newly arisen mutations as being of either complete or mosaic type. However, out of 56 SLRLM lines tested, 11 were found to be mosaic and 13 were completely penetrant SLRLM (Table II). We note that when males from the LEL class of 15.1–30% were tested, the frequency of lines found to be normal (18%) was much lower than in the LEL ranges of 0–15 (50%) or 30.1–45 (44%), although we observed a large number of F_1 males with LEL frequencies in this range.

The results given in Table I demonstrate that a number of SLRLM are strictly recessive and do not reduce the viability of heterozygous male carriers during the pre-imaginal stages of development. From the several lines available we then could choose those that did not reduce adult competitiveness for releases. The results obtained from the competitiveness of males in five lines with different SLRLM are presented in Table III.

In the competitiveness tests the females were expected to produce either normal or mutant offspring depending on which male a female mated with. Most females produced homogeneous progeny (all normal or all mutant). Mixed progeny were detected in less than 10% of the crosses. Therefore, all tests of significance were carried out, using Chi-square analysis, by comparing groups with $K_c < 0.5$ or groups with $K_c > 0.5$ and using an expectation of 0.5 or with a comparison of two of the observed distributions. There were no significant differences in the males without SLRLM from different lines and therefore the data were grouped as controls. Also, there were no significant differences owing to different age groups. Control males invariably were more competitive than dark males when more than four days old.

The average K_c of males heterozygous for SLRLM was more than 0.5 in all of the lines (Table III). As compared with mutant dark males, we found significantly higher competitiveness in males heterozygous for SLRLM from strains L-67 and L-106 at the age of more than four days and from strains L-3 and L-106 at the age of less than four days.

Because we were limited by the total number of males tested, we could not find significant differences between heterozygous males with various SLRLM, but some of them were more competitive than normal males (Table IV). A significantly higher degree of competitiveness was shown in strain L-3 at the age of less than four days and for L-106 when data for both age groups were combined (Table IV).

We conducted a large number of experiments with the codling moth aimed at the induction of sex chromosome translocations. F_1 and F_2 females were tested to detect 'complete' and mosaic translocations. Low and high dosages for irradiation of females (1–12 krad) were used.¹ We also tried combined radiation of both sexes [2]

¹ 1 rad = 1.00×10^{-2} Gy.

TABLE IV. DIFFERENCE BETWEEN AVERAGE COMPETITIVENESS COEFFICIENTS OF SLRLM HETEROZYGOUS MALES AND NORMAL MALES

Conventional SLRLM designation	Age of competing males (d)		Total
	1-4	>4	
L-3	0.51 ^a	-0.02	0.27
L-67	0.16	0.24	0.20
L-106	0.27	0.05	0.18 ^a
L-109	0.12	-0.05	0.04
L-502	0.12	0.12	0.12

^a Significant difference at probability > 0.95.

at the adult stage and at earlier stages of development. However, we have not yet succeeded in isolating a Z/W translocation, although we have tested more than 3000 F₁ females.

4. DISCUSSION

The induction and isolation of SLRLM in species where males are the homogametic sex do not pose great difficulties even in the case of species whose genetics have not been previously studied. The data presented in this article support this point and provide examples of other species where such mutations have previously been studied, such as in the silkworm [6], the grape berry moth [7] and the flour moth [8].

In species in which stage specific embryonic lethals cannot be directly observed, this presents an additional problem. However, one can assess the frequency of LEL and obtain good results, such as in the grape berry moth [7]. In all cases, the observation of a shift in the sex ratio in favour of males can serve as an additional criterion. The presence of markers on the sex chromosomes that affect morphological characters provides a more reliable method of identifying SLRLM [8].

The induction of translocations between the Z and W sex chromosomes is a much more complicated step in the creation of strains with balanced SLRLM. Even when irradiation is used the frequency of such translocations is only about 0.007% in the silkworm [3]. Strunnikov's investigations, in which adult females were irradiated with 30 Gy of gamma rays, are the only successful attempts to induce such reciprocal sex chromosome translocations in lepidopterous females. The probability

of inducing Z/W translocations might be increased by using different radiation doses or kinds of radiation, or by treating different stages of gametogenesis and other factors that might influence the frequency of the translocations induced.

However, our attempts to throw light on this problem have failed. Evidently, the major obstacle is the low resolving power of the screening methods applied. For the isolation of sex chromosome translocations, the use of males with recessive lethal inherited markers in the heterozygous state is theoretically possible, but at least for the codling moth this does not seem to be acceptable in practice.

In order to improve methods of isolating Z/W translocations, we have suggested the use of conditional lethal SLRLM. The presence of such mutations (temperature sensitive or insecticide susceptible mutations) would permit us to develop selective systems for the isolation of Z/W translocations and to develop genetic sexing systems as well. We have started experiments on the isolation of conditional lethal mutations.

Methods for the isolation of sex chromosome translocations could be vastly improved if recessive or dominant morphological mutations on the Z-chromosome were available, providing the survival of the homozygotes was possible. Such mutations have already been found in various lepidopterous pests, e.g. *Ephestia cautella*, *E. kühniella* and *Pectinophora gossypiella*. For these species the construction of strains with balanced SLRLM is possible. For other species, e.g. the codling moth, the required mutations (sex linked lethals, conditional lethals, mutations affecting morphological characters and later sex chromosome translocations) are still worthwhile objectives.

5. CONCLUSIONS

We consider that strains with balanced SLRLM could be used for the control of lepidopterous pests. This method would be especially suited for pests where repeated releases of fully sterilized insects to overwhelm the natural population are not economically feasible because of (1) the high cost of rearing the required quantities of insects, or (2) the reduction in competitiveness of the released insects owing to radiation treatments.

Our experience with the induction and study of SLRLM in the codling moth shows that such mutations (that have the desired effect of reducing the number of females) can be induced and that some of these mutations can increase the competitiveness of the heterozygous male carriers. These observations provide additional support for the view that other kinds of genetic control methods can perhaps be more efficient than the less efficient method of complete sterilization.

In addition, the eventual use of two strains with balanced SLRLM (as shown in Fig. 2) would provide a twofold reduction in the cost of mass rearing because it would be possible to rear males only. Strains heterozygous for only one SLRLM are now available in the codling moth and they reduce the rearing cost by 12.5–25%.

ACKNOWLEDGEMENTS

I would like to thank L.E. LaChance, A.C. Bartlett and E. Busch-Petersen for revising the manuscript.

REFERENCES

- [1] STRUNNIKOV, V.A., "Use of the method for producing entirely male progeny in *Bombyx mori* for insect pest control", Genetic Methods of Insect Pest and Mite Control (Proc. Symp. Yerevan, 1976), Academy of Sciences of the Armenian SSR (1976) 7-8 (in Russian).
- [2] STRUNNIKOV, V.A., Sex control in silkworms, Nature (London) 255 (1975) 111-113.
- [3] STRUNNIKOV, V.A., personal communication.
- [4] STRUNNIKOV, V.A., On the prospects of using balanced sex-linked lethals for insect pest control, Theor. Appl. Genet. 55 (1979) 17-21.
- [5] INAGAKI, E., OSTER, I.I., Changes in the mutational response of silkworm spermatozoa exposed to mono- and polyfunctional alkylating agents following storage, Mutat. Res. 7 3 (1969) 425-432.
- [6] LEZHENKO, S.S., Characters of embryonic sex-linked lethals in silkworm, Silkworm Breeding 66 3 (1975) 12-14 (in Russian).
- [7] HACHSTRYAN, G.G., "Induced lethal mutations in the grape berry moth", Session of the Armenian Branch of the All-Union Genetics and Selection Soc., 1980, Yerevan, p. 75 (abstract) (in Russian).
- [8] MAREC, F., personal communication.
- [9] ANISIMOV, A.I., LITVINOVA, E.M., LAZURKINA, N.V., "Research on partial genetics of the apple worm", Proc. Int. Congr. on Genetics, Moscow, 1977, Part 1, p. 497 (abstract) (in Russian).
- [10] ANISIMOV, A.I., LAZURKINA, N.V., SHVEDOV, A.N., "Radiation induced genetic damages influencing the suppressive effect of inherited sterility in the codling moth", IAEA-SM-301/2P, these Proceedings.

**DIVERSITY AMONG *Bacillus thuringiensis*
ACTIVE AGAINST THE
MEDITERRANEAN FRUIT FLY,
*Ceratitis capitata***

R.E. GINGRICH, T.S. EL-ABBASSI
FAO/IAEA Entomology Unit,
IAEA Seibersdorf Laboratory,
Vienna

Abstract

DIVERSITY AMONG *Bacillus thuringiensis* ACTIVE AGAINST THE MEDITERRANEAN FRUIT FLY, *Ceratitis capitata*.

Procedures were developed to screen rapidly isolates of the entomopathogen *Bacillus thuringiensis* against adults of the Mediterranean fruit fly, *Ceratitis capitata*, and simultaneously characterize its active agents on the basis of their water solubility and heat stability. Fermentation products in solution, in suspension or dried were bioassayed. Heat stable, soluble exotoxins were the most frequently found active agents; some strains produced exotoxins that precipitated and their activity was found in the sediment fraction of fermentation beers. Insoluble heat labile agents were found that upon subsequent preparation were identified as active spores. The activity of spores from different isolates was different. One isolate produced endotoxin that, although inactive when bioassayed alone, had synergistic activity when combined with spores.

1. INTRODUCTION

In sterile insect technique (SIT) programmes against the Mediterranean fruit fly (medfly), aerial bait sprays containing malathion as the active insecticide are commonly used to suppress populations of wild flies before release of the steriles. This method of suppression is effective. However, its continued use is threatened because of concern over the adverse effects of malathion on the environment [1]. Loss of malathion use would cause serious problems for SIT eradication programmes.

Preliminary data has been reported that the bacterial entomopathogen *Bacillus thuringiensis* produces agents that are lethal when ingested by adult medflies [2]. *Bacillus thuringiensis* is the designation for a complex of varieties and isolates, many of which are known to produce a variety of agents that are more or less specifically active against many different species of insects. The best known and most widely used of the insecticidal agents is the crystalline inclusion body that contains δ -endotoxin. It is the basis for most commercial preparations currently available and used in Europe and North America. The endotoxin is quite safe for mammals and is produced in a variety of forms which can be exploited for specificity against

selected target insects. *Bacillus thuringiensis* also produces spores that are pathogenic for a few insects, particularly when they are combined with an endotoxin.

The spores and, except in highly alkaline environments, crystals are insoluble in water. The insecticidal properties of both are labile to normal autoclaving temperatures; spores, but not endotoxins, are made inactive by various forms of short wave radiation.

The bacterium also produces various exotoxins that are water soluble and given off during growth into the surrounding medium. With one exception, the exotoxins have received little study. The exception is thuringiensin, an adenine nucleotide and adenosinetriphosphate (ATP) analogue, that has been chemically identified and synthesized [3]. It is toxic to several species of insects, primarily among Diptera. Thuringiensin is stable at autoclave temperatures, hence its former designation as a heat stable fly factor. It is also toxic for some mammalian systems and, therefore, prohibited for inclusion in commercial preparations of *B. thuringiensis* in Europe and North America. There is evidence of heterogeneity among the heat stable exotoxins, but it has, unfortunately, not been sufficiently followed to determine if there are safer forms of the exotoxins that can be used as insecticides.

This paper presents information to show further that the bacterium *B. thuringiensis* produces a variety of agents that are pathogenic for adult medflies and is, therefore, a potential candidate to replace malathion in bait sprays.

2. MATERIALS AND METHODS

Procedures for preparing products of the bacterium for bioassays were designed to permit rapid screening and simultaneously characterize the nature of the active agents found.

2.1. Preliminary screening

Fermentation was carried out in a medium designated B-4 that contained cottonseed flour, peptone, dextrose, yeast extract and minerals [4]. Inoculated medium was incubated at 30°C in a rotary shaker at 340 rev./min for 96 h. The fermentation beer was separated into soluble (supernatant) and insoluble (sediment) fractions by centrifugation at 12 000g for 15 min. The insolubles were resuspended in one-tenth of their original volume. A portion of each fraction was autoclaved at 120°C for 15 min. The four subfractions were supplemented with 20% sucrose and then bioassayed separately against one day old adult male and female medflies. Mortality was recorded after eight days. By these procedures all products from the fermentation could be bioassayed and any found to be active could be simultaneously characterized by their water solubility and heat stability.

2.2. Critical testing of insoluble products

Powders containing the insoluble by-products of the fermentation were prepared by the lactose-acetone co-precipitation method [5]. These powders were then presented to flies either undiluted or diluted with uninoculated B-4 medium that was also harvested by the lactose-acetone co-precipitation method.

Spores were physically separated from crystals for separate bioassays by the floatation technique [6]. By this method, suspensions of spores and crystals of 90% or greater purity can be obtained for most isolates of *B. thuringiensis*. Purified spores or crystals were also precipitated by the lactose-acetone method to produce purified powders. Whenever the spores and crystals could not be separated by floatation, 10 kGy of gamma radiation was used to selectively inactivate the spores in powders.

3. RESULTS AND DISCUSSION

The data shown in Figs 1-5 illustrate the specificity of the bioassay procedures in detecting and distinguishing between the soluble heat stable exotoxins and the

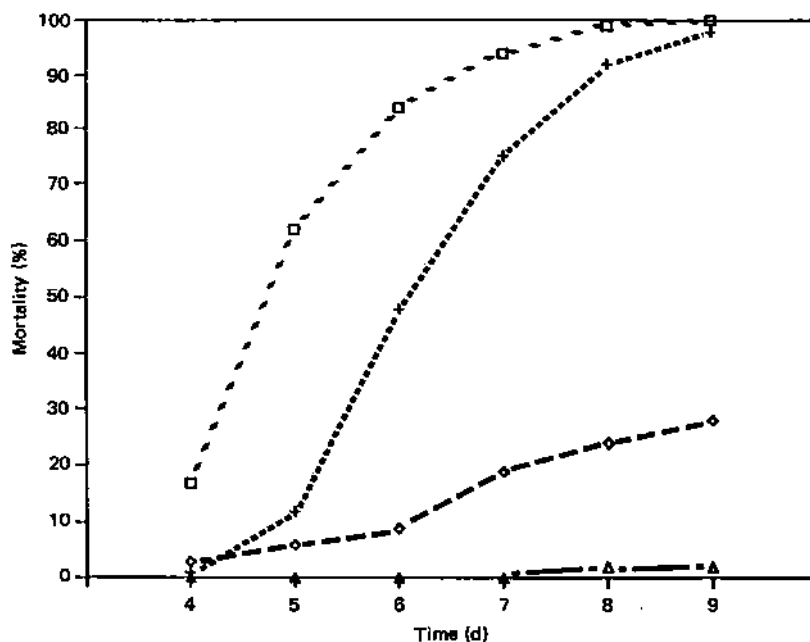

FIG. 1. Mortality response of adult medflies to active agents of *B. thuringiensis*, serovar 1. P (□): supernatant; PA (+): autoclave supernatant; D (◇): sediment; DA (△): autoclave sediment.

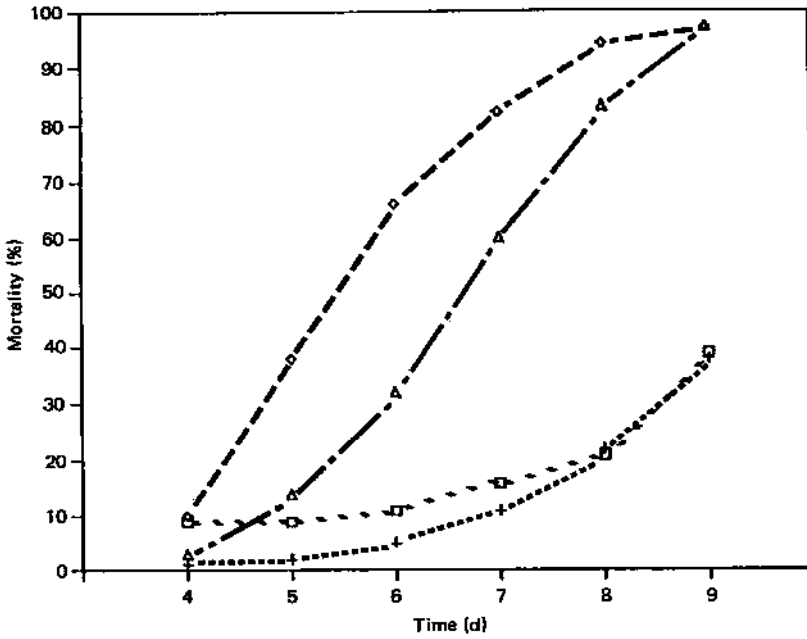

FIG. 2. Mortality response of adult medflies to active agents of *B. thuringiensis*, serovar 9 (see Fig. 1 for explanation of symbols).

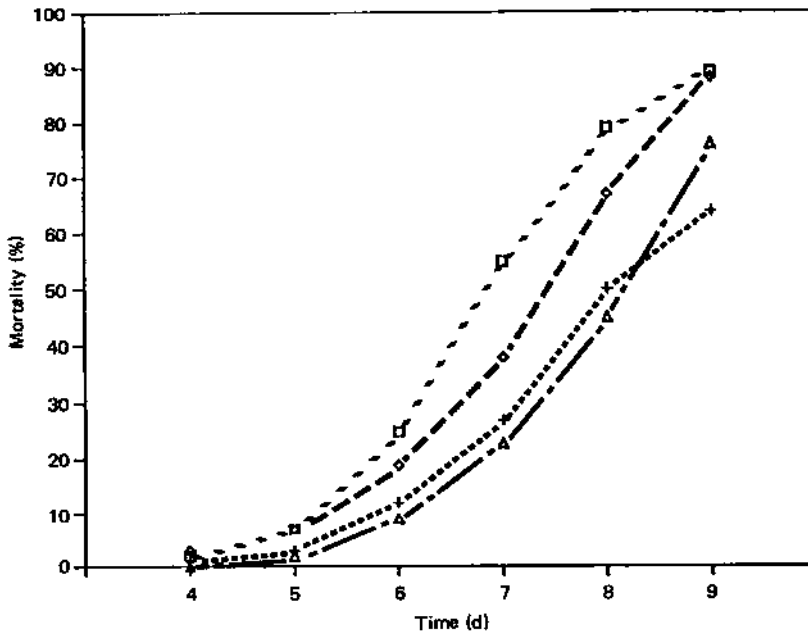

FIG. 3. Mortality response of adult medflies to active agents of *B. thuringiensis*, serovar 9 (see Fig. 1 for explanation of symbols).

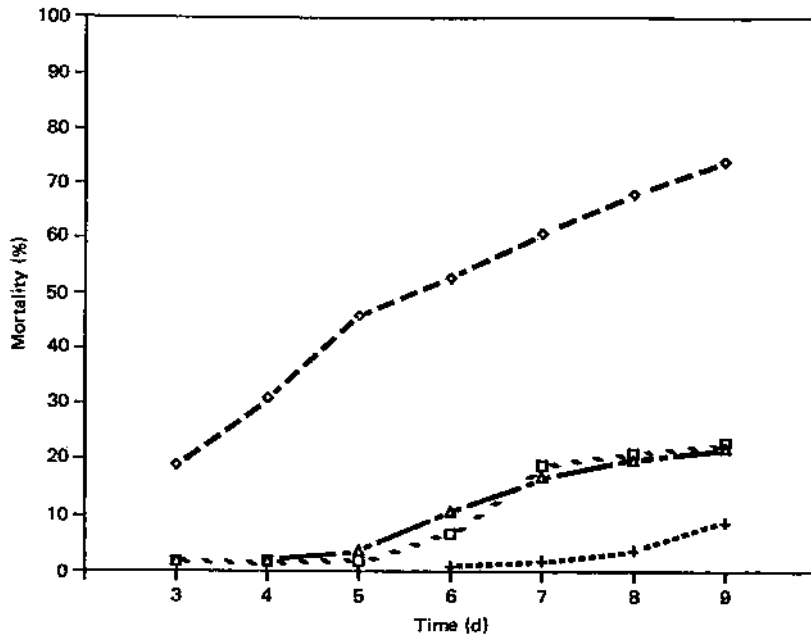

FIG. 4. Mortality response of adult medflies to active agents of *B. thuringiensis*, serovar 8ab (see Fig. 1 for explanation of symbols).

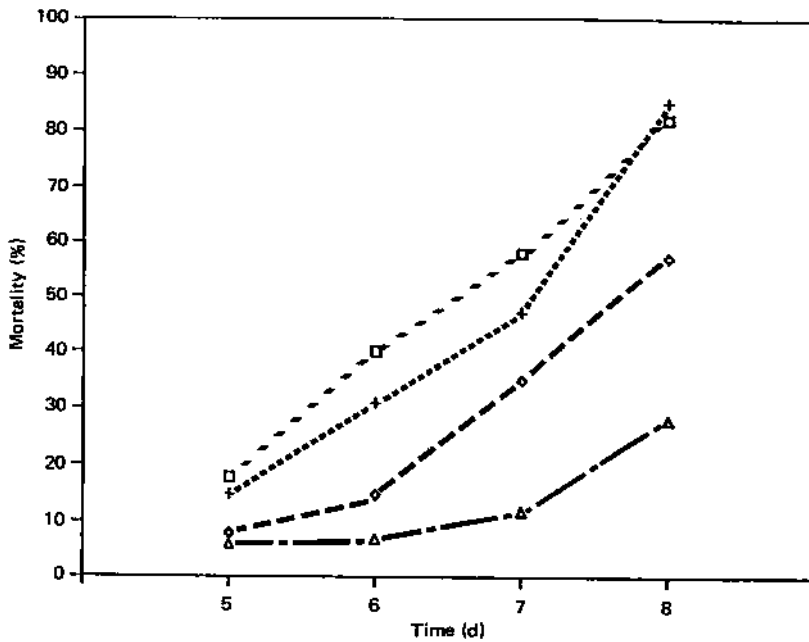

FIG. 5. Mortality response of adult medflies to active agents of *B. thuringiensis*, serovar 9 (see Fig. 1 for explanation of symbols).

TABLE I. MORTALITY AFTER FOUR DAYS AMONG ADULT MEDFLIES FED VARYING COMBINATIONS (BY PERCENTAGE) OF *B. thuringiensis* SPORES AND CRYSTALS IN TREATMENT POWDERS

Isolate	Mean percentage of mortality (\pm SD) at indicated percentage of spores-crystals					
	0-0	0-20	10-0	10-5	10-10	10-20
135	0	3.0 \pm 2.7	24.7 \pm 9.0	31.7 \pm 4.5	28.7 \pm 10.9	31.3 \pm 4.7
266	0	6.3 \pm 10.1	61.7 \pm 11.2	71.7 \pm 10.6	77.7 \pm 15.3	73.7 \pm 6.7
767	0	1.5 \pm 0.8	49.3 \pm 5.9	55.7 \pm 6.7	57.0 \pm 9.8	68.3 \pm 4.0

TABLE II. TYPES OF ACTIVE AGENTS PRODUCED BY ISOLATES IN VARIOUS SEROVARS OF *B. thuringiensis* (*B.t.*)

<i>B.t.</i> isolate		Percentage of isolates with active		
Serovar	No. tested	Spores	Exotoxins	Endotoxins*
1	17	0	41	0
2	1	0	0	0
3a	1	0	0	0
3ab	15	7	7	0
4ab	1	0	0	0
4ac	4	0	25	0
5ab	14	0	7	0
6	4	0	0	0
7	25	4	44	0
8ab	22	68	0	5**
9	4	0	75	0
10	4	0	50	0
11ab	1	0	0	0
12	1	0	0	0
14	5	0	0	0

* Only tested for a few selected isolates.

** Synergistic effect with spores.

TABLE III. COMPARISON OF LC_{50} DETERMINATIONS AND SLOPE VALUES (b) FOR DIFFERENT ISOLATES AND FERMENTATIONS OF ISOLATES OF *B. thuringiensis*
(Values are means for three or more assays)

Parameter	Mean LC_{50} and b for indicated <i>B.t.</i> powders*				
	135 (3)	266 (10)	266 (12)	767 (3)	767 (6)
$LC_{50} + SD \times 10^6$	1.06 ± 0.33	3.53 ± 0.90	2.95 ± 1.01	2.88 ± 0.52	3.29 ± 1.91
$b \pm SD$	1.05 ± 0.02	0.97 ± 0.01	1.03 ± 0.02	1.44 ± 0.03	1.48 ± 0.08

* Numbers in parentheses denote separate fermentation batches.

insoluble, heat labile spores and/or endotoxins. The isolate shown in Fig. 1 produced a predominantly heat stable, soluble exotoxin, whereas the one shown in Fig. 2 produced a predominantly heat stable, insoluble exotoxin. The one shown in Fig. 3 produced insoluble and soluble exotoxins in nearly equal amounts. The isolate shown in Fig. 4 did not produce an exotoxin, but rather insoluble, heat labile active agents that were later identified as spores. Figure 5 shows an isolate that produced considerable amounts of both heat stable and heat labile agents. By comparing the figures it is apparent that the exotoxins were more potent than the insoluble agents.

A distinction between activity from spores and the endotoxin was made by bioassays of purified spores and crystals, separately or in combinations, and either in suspension or as powders. When it was not possible to separate spores from crystals by floatation, gamma radiation was used. The results for powders in Table I show that the activity in isolates 135 and 266 was solely from spores. The endotoxin, alone or in combination, had no effect. However, for isolate 767, the activity, although primarily related to spores, was also affected by the endotoxin. The endotoxin effect appeared to be proportional to its concentration; the endotoxin alone had no effect.

The relation of agents active against adult medflies to the taxonomic status of the bacterial isolates that produced them are shown in Table II. From the data it is apparent that exotoxins, most frequent among isolates in serovars 1, 4ac, 7, 9 and 10 were the most common agents found. These serovars are well known for producing exotoxins that are active against other dipterous species. Most interesting were the abundant isolates in serovar 8ab that had active spores. One of these isolates (767) was compared for activity against the active spore isolates in serovars 3ab (266) and 7 (135).

The results of lethal concentration 50 (LC_{50}) determinations in Table III show that isolate 135 produced the most active spores. A comparison of slope values for

the regression lines suggests that the mode of action in isolate 767 may be different from the other two. From Table II it was seen that the endotoxin interacted with spores to produce a synergistic effect. Possibly this endotoxin involvement caused the deviation in the slope of the regression line for 767.

REFERENCES

- [1] TROETSCHLER, R.G., Effects on nontarget arthropods of malathion bait sprays used in California to eradicate the Mediterranean fruit fly, *Ceratitis capitata* (Wiedemann) (Diptera: Tephritidae), *Environ. Entomol.* **12** (1987) 1816.
- [2] GINGRICH, R.E., EL-ABBASSI, T.S., Demonstration of *Bacillus thuringiensis* as a potential control agent for the adult Mediterranean fruit fly, *Ceratitis capitata* (Wied.), *J. Appl. Entomol.* (in press).
- [3] SEBESTA, K., FARKAS, J., HORSKA, K., "Thuringiensin, the β -exotoxin of *Bacillus thuringiensis*", *Microbial Control of Insects and Mites* (BURGES, H.D., Ed.), Academic Press, London and New York (1981) 249.
- [4] DULMAGE, H.T., Production of the spore δ -endotoxin complex by variants of *Bacillus thuringiensis* in two fermentation media, *J. Invertebr. Pathol.* **16** (1970) 385.
- [5] DULMAGE, H.T., CORRERA, J.A., MARTINEZ, A.J., Coprecipitation with lactose as a means of recovering the spore-crystal complex of *Bacillus thuringiensis*, *J. Invertebr. Pathol.* **15** (1970) 15.
- [6] GINGRICH, R.E., A floatation procedure for producing spore-free crystals from commercial formulations of *Bacillus thuringiensis* var. *thuringiensis*, *J. Invertebr. Pathol.* **10** (1968) 180.

INDUCTION AND USE OF SEX LINKED LETHAL MUTATIONS IN THE PINK BOLLWORM

A.C. BARTLETT

Western Cotton Research Laboratory,
Agricultural Research Service,
United States Department of Agriculture,
Phoenix, Arizona,
United States of America

Abstract

INDUCTION AND USE OF SEX LINKED LETHAL MUTATIONS IN THE PINK BOLLWORM.

The sterile insect release technique can often be improved by removal of females before release. Rearing efficiencies can also be increased if removal of the females occurs at early developmental stages. In order to begin to develop genetic sexing strains for the pink bollworm, *Pectinophora gossypiella* (Saunders), it was necessary to determine the best dosage of radiation for induction of viable sex linked recessive lethal mutations and to see if stocks containing induced sex linked lethals could be maintained in culture. Sex linked recessive lethal mutations can be detected by distorted sex ratios in the progeny of treated adults. However, in the pink bollworm, highly distorted sex ratios are common even in the absence of induced mutations. Therefore, a visible sex linked trait, purple eye, was used as a marker for the untreated X-chromosomes in crosses. Thus, the presence of a recessive sex linked lethal mutation induced by the radiation treatment may be detected by the combination of an abnormal sex ratio (2 males:1 female) and the absence or relative absence (depending on cross-over percentages between the induced lethal and the purple locus) of wild-type females. The percentage of induced sex linked lethal mutations as measured by the percentage of males in the total progeny was relatively linear over the dose range 0-7.5 krad. The percentage of recessive sex linked lethal mutations caused by doses of radiation over 7.5 krad was extremely variable owing to induced dominant lethal effects. However, the percentage of induced sex linked lethal mutations as measured by the absence of wild-type females was extremely variable over all doses tested. Two sex linked lethal strains isolated during this experiment produced very low percentages (0-5%) of wild-type females in each generation (presumably as a result of crossing-over) and have been maintained for over two years.

1. INTRODUCTION

The pink bollworm, *Pectinophora gossypiella* (Saunders), is a serious economic pest of cotton (*Gossypium* spp.) in many areas of the world. Infestations of this insect cause loss of fiber yield, decline in fiber quality, losses due to seed damage and increased production costs for control. A number of cultural control procedures have been developed which helped to relegate the pink bollworm to a minor pest status in Texas [1], but these procedures have not been applied in Arizona or southern California, where insecticidal treatments often start

in mid-July and are scheduled on a regular basis (weekly or more often) until harvest time in October or November [2]. Control of the pink bollworm by insecticides has led to an increase in problems with pests which had previously been of little economic importance, such as the cotton leaf perforator, Bucculatrix thurberiella Busck, tobacco budworm, Heliothis virescens F., cotton bollworm, Heliothis zea Boddie and spider mites, Tetranychus spp.

A sterile insect release and cultural control program for the pink bollworm has been conducted in the San Joaquin Valley of California since 1968. This program has prevented the spread and establishment of the pink bollworm into that area [3]. However, the use of sterile insect releases in areas where the pink bollworm is fully established has not been successful [4] and probably will not be useful until field populations are reduced to very low levels by an integrated program of many different control procedures.

Almost 20 years of experience with the San Joaquin sterile release program has led to significant improvements in the rearing and delivery of the released insects. For example, a number of pathogens had direct negative effects on moth production and effectiveness of moths in the field. Elimination of those organisms has enabled the mass production facility to consistently meet or exceed production goals [5]. However, continuing problems with the mating competitiveness in the field of mass reared, irradiation sterilized pink bollworm adults need to be solved [3,4].

Bartlett and Lewis [6] produced and maintained strains of pink bollworms that are unable to respond to diapause-inducing conditions. This conditional-lethal character is inherited as a semi-dominant polygenic trait and could be introduced to feral populations by massive releases of fertile, laboratory reared insects which carry the trait (thus avoiding the effects of radiation sterilization). However, if females were released in the numbers needed to insert the character into the field population (where the progeny would be field reared and thus avoid loss of vigor due to transportation procedures), some loss in cotton yield would certainly occur.

This same scenario would occur for any system of genetic control that would require release of fertile insects for the distribution of the trait into field populations. Genetic sexing schemes have been developed for several species of mosquitoes using insecticide resistance genes and translocations [7, 8, 9]. An alcohol dehydrogenase locus and a Y-linked translocation was used in Drosophila melanogaster Meigen to kill female larvae during development [10]. In Lepidoptera the only successful application of genetic sexing techniques has been in Bombyx mori L. using the induction of sex linked recessive lethal mutations and W-linked translocations [11]. We have been studying the induction and maintenance of

2.1. Test 1

Caesium-137 gamma radiation was administered to six groups of 40 wild-type males plus a control group of the same size as follows: 0 (control), 1.5 krad, 3.0 krad, 6.0 krad, 12.0 krad, and 15.0 krad.¹ The treated males were crossed with groups of 40 purple females. F₁ progeny from each cross were checked for phenotype and sex ratio. F₁ wild-type males (30 replicati-
ons/dose) were then individually test-crossed with 5 purple females. The test-cross progeny were sexed as pupae to test for deviation from an expected 1 male : 1 female ratio.

2.2. Test 2

Four doses of Cs-137 gamma radiation plus a control were given to wild-type males as follows: 0 (control), 3.3 krad, 6.6 krad, 9.9 krad, and 13.2 krad. Five replications of crosses of 40 treated wild-type males and 40 untreated purple females were set up. F₁ progeny from each of the crosses were checked for sex ratio and phenotype. F₁ wild-type males (50 replicati-
ons/dose) were then test-crossed with purple females. The test-cross populations were checked for sex ratio and phenotypic distribution. Populations showing sex ratio distortions, in which the proportion of wild-type females was less than 15% of the total population, were carried for further generations by discarding all purple males and wild-type females and retaining only wild-type males and purple females from each generation.

2.3. Test 3

Five doses of Cs-137 gamma radiation plus a control were given to wild-type males as follows: 0 (control), 1.5 krad, 3.0 krad, 4.5 krad, 6.0 krad, and 7.5 krad. Fifteen treated males were crossed to 45 purple females in each of five replications for each dose. F₁ and test-cross progeny were handled as in Test 2.

2.4. Analysis

Percentages of induced sex linked recessive lethal mutations are measured as follows: (1) as an increase in the percentage of male pupae to total pupae (expected value with no lethal = 50%); (2) as an increase, over the expected 50%, in the ratio of wild-type males to the total number of wild-type progeny (since the presence of a sex linked recessive lethal

¹

1 rad = 1.00 X 10⁻² Gy.

mutation results in the absence or reduction of numbers of wild-type females in a family); or (3) as a decrease, from the expected value of 25%, in the ratio of wild-type females to total progeny. Mean differences were tested by t-test at the 0.05 level of significance and deviations from expected ratios were tested by Chi-square analysis at the 0.05 level of significance [15].

Crossing-over between the purple locus and an induced lethal can be estimated by the presence of low numbers of wild-type females in progeny that show a distorted sex ratio. Since wild-type females can be produced by a recombination of the lethal allele on the wild-type chromosome with its normal allele on the purple bearing chromosome (thus causing the recombinant purple females to die), the proportion of wild-type females among all progeny is equal to one-half the proportion of crossing-over.

3. RESULTS

3.1. Test 1

The number of progeny and percentage of adults and males from each dose are shown for the F_1 in Table I. No purple progeny were expected in the F_1 and none were found. No difference was found between the number of male and female pupae by paired t-test ($t = 1.27$, 5 df) for the F_1 progeny. However, a highly significant difference ($t = 5.62$, 5 df) was found when the number of males for each dose was compared with an expectation of 50% males. This difference was due to the high percentage of males in each cross, irrespective of radiation dose. There were significantly less progeny produced

TABLE I. NUMBER OF F_1 PROGENY AND PERCENTAGES OF ADULTS AND MALES PRODUCED BY CROSSES OF IRRADIATED WILD-TYPE MALES WITH UNTREATED PURPLE FEMALES (40 MALES AND 40 FEMALES PER DOSE)

Dose (krad)	Number of F_1 progeny					
	Male pupae	Female pupae	Wild-type males	Wild-type females	Adults (%)	Males (%)
0	180	132	173	115	92	60
1.5	264	221	234	183	86	58
3.0	169	138	149	114	86	57
6.0	266	196	239	185	92	56
12.0	55	26	51	24	93	68
15.0	16	18	12	7	56	63

TABLE II. AVERAGE NUMBER OF TEST-CROSS PROGENY AND PERCENTAGE OF MALES PRODUCED BY SINGLE F₁ MALES CROSSED WITH FIVE PURPLE FEMALES (30 REPLICATIONS PER DOSE)

Dose (krad)	Number of test-cross progeny				
	Male pupae	Female pupae	Males (%)	95% confidence limits on % males	
				Lower	Upper
0	58.1	52.2	53	45	61
1.5	78.3	42.2	65	56	71
3.0	22.0	22.6	49	39	59
6.0	20.4	17.1	54	44	65
12.0	0.1	0.4	25	14	36
15.0	0.2*	0.2	50	0	100

* Average of 13 replications.

TABLE III. NUMBER OF F₁ PROGENY AND PHENOTYPIC PERCENTAGES PRODUCED BY RADIATION TREATED WILD-TYPE MALES CROSSED WITH PURPLE FEMALES (40 MALES AND 40 FEMALES PER DOSE CROSSED IN MASS)

Dose (krad)	Number of F ₁ progeny					
	Male pupae	Female pupae	Wild-type males	Wild-type females	Adults (%)	Males (%)
0	167	158	155	148	93	51
3.3	196	166	160	136	82	54
6.6	294	180	275	160	92	62
9.9	111	67	87	50	77	62
13.2	23	10	19	7	79	70

by the 12 and 15 krad doses than for any of the other doses or the control.

The number of test-cross pupae and percentage of males for each dose in Test 1 are shown in Table II. The values in Table II are averages for up to 30 single male crosses. The number of progeny from males treated at 12 and 15 krad was significantly reduced compared with the control and all other radiation doses. On the other hand, the numbers of test-cross progeny treated with doses of 3 and 6 krad were not

significantly different from the control because of high variability in progeny number for all crosses. In the test-cross progeny, only the 12 krad treatment changed the expected sex ratio significantly and that was in the wrong direction.

3.2. Test 2

A significant difference was found between numbers of F₁ male and female pupae over doses ($t = 2.20$, 4 df) and for the

TABLE IV. AVERAGE NUMBER AND PHENOTYPIC PERCENTAGES OF TEST-CROSS PROGENY PRODUCED BY SINGLE F₁ MALES CROSSED WITH FIVE PURPLE FEMALES (50 REPLICATIONS PER DOSE)

Dose (krad)	Number of test-cross progeny				
	Male pupae (± SEM)	Female pupae (± SEM)	% males from pupae (± SEM)	% wild-type males (± SEM)	% wild-type females (± SEM)
0	24.6 (4.3)	22.7 (4.1)	43 (3)	36 (4)	23 (3)
3.3	8.0 (1.7)	7.2 (1.6)	40 (4)	27 (5)	22 (5)
6.6	2.5 (0.7)	2.7 (0.8)	36 (5)	24 (5)	14 (4)
9.9	2.1 (0.8)	1.8 (0.6)	31 (5)	14 (5)	26 (7)
13.2	5.4* (2.1)	4.9 (1.8)	35 (7)	40 (9)	20 (7)

* Average of 18 replications.

TABLE V. NUMBER OF F₁ PROGENY AND PHENOTYPIC PERCENTAGES PRODUCED BY RADIATION TREATED WILD-TYPE MALES CROSSED WITH PURPLE FEMALES (FIVE REPLICATIONS OF 15 MALES X 45 FEMALES)

Dose (krad)	Number of F ₁ progeny			
	# male pupae (± SEM)	# female pupae (± SEM)	% male pupae (± SEM)	% wild-type males (± SEM)
0	308 (23)	270 (20)	53 (0.1)	52 (0.1)
1.5	273 (48)	230 (30)	53 (2)	54 (2)
3.0	290 (8)	231 (11)	56 (1)	56 (1)
4.5	278 (16)	229 (17)	55 (2)	55 (2)
6.0	225 (46)	166 (31)	57 (1)	57 (2)
7.5	145 (15)	98 (2)	59 (2)	61 (2)

TABLE VI. AVERAGE NUMBER AND PERCENTAGES OF TEST-CROSS PROGENY PRODUCED BY F₁ WILD-TYPE MALES CROSSED WITH PURPLE FEMALES (FIFTY REPLICATIONS OF 1 MALE X 5 FEMALES)

Dose (krad)	# male pupae (± SEM)	# female pupae (± SEM)	% male pupae (± SEM)	% wild-type males (± SEM)	% wild-type females (± SEM)
0	103 (8)	94 (7)	50 (2)	49 (2)	24 (1)
1.5	79 (8)	72 (8)	50 (2)	50 (2)	21 (1)
3.0	41 (6)	36 (6)	50 (3)	47 (3)	24 (3)
4.5	22 (5)	20 (4)	48 (4)	47 (4)	18 (2)
6.0	20 (5)	17 (4)	37 (4)	33 (4)	19 (3)
7.5	12 (3)	9 (2)	45 (5)	45 (5)	12 (3)

TABLE VII. NUMBER OF F₃ MASS CROSSES (TEST-CROSS WILD-TYPE MALES X PURPLE FEMALES) MADE FOR EACH DOSE IN TESTS 2 AND 3 IN WHICH TEST-CROSS PROGENY SHOWED LESS THAN 15% WILD-TYPE FEMALES

Dose (krad)	No. of F ₃ crosses	No. with distorted sex ratio (%)	No. of confirmed lethals (%)
<u>Test 2</u>			
0	7	2 (29)	1 (14)
3.3	7	2 (29)	0 (0)
6.6	2	1 (50)	0 (0)
9.9	3	1 (33)	1 (33)
13.2	7	0 (0)	0 (0)
<u>Test 3</u>			
0	5	0 (0)	0 (0)
1.5	7	4 (57)	1 (14)
3.0	12	5 (42)	0 (0)
4.5	14	4 (29)	1 (7)
6.0	11	4 (36)	2 (18)
7.5	9	7 (78)	2 (22)

difference between numbers of male and female adults over doses ($t = 3.53$, 4 df) (Table III). More males than females were found at 6.6 and 9.9 krad for numbers of pupae (mean significant difference (msd) = 42) and at 3.3, 6.6 and 9.9 krad doses for numbers of adults (msd = 35). No difference was found in the percentage of adult emergence over doses ($\chi^2 = 3.32$, 4 df).

No significant difference was found between numbers of test-cross male and female pupae ($t = 1.88$, 4 df) (Table IV). There were significantly fewer total males than expected in the test-cross ($t = -6.27$, 4 df), but no difference in the average number of wild-type females ($t = -2.0$, 4 df).

3.3. Test 3

There were highly significant differences between numbers of F₁ male and female pupae from males treated at radiation doses of 6 and 7.5 krad ($t = 14.18$, 5 df, msd = 49.2) (Table V). Highly significantly more male pupae came from males treated with 6 and 7.5 krad ($t = 5.74$, df = 5) than the expected 50% ratio. Also, a significantly higher percentage of males was produced at 7.5 krad than at any of the other doses. The percentages of males sired by control males were much less variable over replications than percentages from radiation-treated males.

There were significantly fewer test-cross progeny produced in all of the radiation doses than in the control (Table VI). The percentages of test-cross males among pupae and the percentage of wild-type test-cross males among adults showed no differences among doses, including the controls. However, the percentages of wild-type female test-cross progeny among all of the test-cross progeny was significantly lower than the expected 25% ratio for 4.5 and 7.5 krad doses.

TABLE VIII. NUMBER OF WILD-TYPE AND PURPLE PROGENY OVER GENERATIONS FOR STRAINS L02 AND L05

Generation	# wild-type males	# wild-type females	# purple males	# purple females
<u>Strain L02</u>				
3	4	0	7	8
4	37	0	51	41
5	42	2	38	40
6	82	0	120	75
<u>Strain L05</u>				
3	90	1	131	181
4	175	2	270	256
5	14	0	11	10
6	9	0	14	8

3.4. Maintenance Of Lethal Stocks

Table VII shows the numbers of crosses made for each dose in Tests 2 and 3 from test-cross replications which showed less than 15% wild-type females (no F₃ crosses were made for Test 1). No trend is apparent in either test toward increasing numbers of putative lethals with increasing dose. In fact, the numbers with distorted sex ratios in the F₃ generation are quite similar over doses.

Two strains established from Test 2 produce very low percentages (0 - 5%) of wild-type females each generation. One strain (L02) was isolated from a control mating and was thus a naturally occurring recessive lethal mutation. The second strain (L05) was derived from the 9.9 krad dose. Table VIII illustrates some typical generation data for these strains. The numbers of wild-type males are generally reduced in these strains compared with the numbers of purple males. The strains do not show wild-type females every generation. In fact, strain L05 produces wild-type females more consistently than strain L02.

4. CONCLUSIONS

The effects of high doses of radiation on reproductive performance of the pink bollworm are well documented [16]. Increasing dosage of radiation (above a dose of ca. 6 krad) leads to a decrease in the number of progeny. Similar results are shown in the tests reported here. One interesting result of these tests is that doses of 1.5 to 4.5 krad given to males do not significantly lower the number of F₁ progeny (in some cases numbers were slightly, but not significantly, increased). However, doses of radiation over 3 krad did lower the production of test-cross progeny from F₁ males in each of these tests.

In spite of the obvious efficiency and consistency of radiation in lowering the reproductive performance of F₁ males, the detection of induced sex linked lethal mutations was not efficient or consistent. The inefficiency was due largely to the high natural variability of sex ratio data for the pink bollworm. The 95% confidence limits for percent males from 30 control matings in Test 1 were from 45% to 61%. A sex linked lethal mutation would be expected to give a sex ratio of 66% males from a test-cross. Any effect of the lethal upon a heterozygous male and/or the presence of crossing-over could be expected to reduce that percentage. Thus, it becomes very difficult to detect the presence of sex linked recessive lethals on the basis of sex ratio alone.

The use of the sex linked visible genetic marker, purple eye, increased our ability to detect induced and spontaneous

lethal mutations through the observation of distorted wild-type female ratios in test-crosses. Doses of radiation between 6 and 9 krad increased the average frequency of F_1 males and significantly reduced the average number of wild-type females. Doses of radiation in excess of 9 krad had such a detrimental effect upon reproduction that detection of sex linked lethals was unreliable because of sterility.

Sex linked lethal mutations were detected in the crosses reported in these tests. Two of these lethals have been maintained over 2 years since their establishment. These lethal mutations are located on the sex chromosome of the pink bollworm along with the purple locus. Thus, this report constitutes the first occurrence of chromosomal linkage in the pink bollworm. The L05 locus shows about 0.5% crossing-over with the purple locus, if we assume that the occurrence of wild-type females in the progeny of crosses between L05 wild-type males and purple females is due to crossing-over and not due to spontaneous reversion of the lethal locus. Until more loci are identified on the sex chromosomes of the pink bollworm, it is not possible to distinguish between these two possibilities.

One of the purposes for these experiments was to determine if genetic sexing systems could be developed in the pink bollworm using the techniques suggested by Strunnikov [12]. These tests show that sex linked lethal mutations can be induced and maintained in culture. The successful production of a genetic sexing scheme using sex linked lethal mutations requires a combination of non-allelic lethals on each X-chromosome of an individual male. The production of such a balanced stock is now being investigated in this laboratory.

REFERENCES

- [1] NOBLE, L. W., Fifty years of research on the pink bollworm in the United States, Agricultural Handbook #357, Agricultural Research Service, U. S. Department of Agriculture, Washington, D. C. (1969).
- [2] REYNOLDS, H. T., "Insecticides for control of pink bollworm populations", Pink Bollworm Control in the Western United States, (GRAHAM, H. M., Ed.), ARM-W-16, Agricultural Research Service, U. S. Department of Agriculture, Oakland, CA (1980) 35-39.
- [3] STATEN, R. T., The use of the sterile pink bollworm for prevention of its spread into the San Joaquin Valley of California, Animal and Plant Health Inspection Service, U. S. Department of Agriculture, Phoenix, AZ, personal communication (1984).

- [4] HENNEBERRY, T. J., KEAVENY, D. F. III, Suppression of pink bollworm by sterile moth releases, ARS-32, Agricultural Research Service, U. S. Department of Agriculture (1985).
- [5] STEWART, F. D., "Mass rearing the pink bollworm, Pectinophora gossypiella", Advances and Challenges in Insect Rearing (KING, E. G., LEPLA, N. C., Eds), Agricultural Research Service, U. S. Department of Agriculture, New Orleans LA (1984) 176-187.
- [6] BARTLETT, A. C., LEWIS, L. J., Response of the pink bollworm (Lepidoptera: Gelechiidae) to long-term selection for the inability to diapause. *Ann. Entomol. Soc. Am.* **80** (1987) 797-803.
- [7] CURTIS, C. F., Genetic sex separation in Anopheles arabiensis and the production of sterile hybrids, *Bull. World. Health. Organ.* **56** (1978) 453-454.
- [8] SEAWRIGHT, J. A., KAISER, P. E., DAME, D. A., LOFGREN, C. S., Genetic method for the preferential elimination of females of Anopheles albimanis, *Science* **200** (1978) 1303-1304.
- [9] SEAWRIGHT, J. A., KAISER, P. E., SUGUNA, S. G., FOCKS, D. A., Genetic sexing strains of Anopheles albimanus Wiedemann, *Mosq. News* **41** (1981) 107-114.
- [10] ROBINSON, A. S., van HEEMERT, C., Genetic sexing in Drosophila melanogaster using the alcohol dehydrogenase locus and a Y-linked translocation, *Theor. Appl. Genet.* **59** (1981) 23-24.
- [11] STRUNNIKOV, V. A., GULAMOVA, L. M., Artificial sex control in Bombyx mori, Communication II. Development of sex-marked hybrids with normally viable males in Bombyx mori, *Genetika* **7** (1971) 58-73.
- [12] STRUNNIKOV, V. A., On the prospects of using balanced sex-linked lethals for insect pest control, *Theor. Appl. Genet.* **55** (1979) 17-21.
- [13] BARTLETT, A. C., Genetics of the pink bollworm: Sooty body and purple eye, *Ann. Entomol. Soc. Am.* **72** (1979) 256-259.
- [14] BARTLETT, A. C., WOLF, W. W., "Pectinophora gossypiella", Handbook of Insect Rearing (SINGH, P., MOORE, R. F., Eds), Vol. II, Elsevier, Amsterdam (1985) 415-430.
- [15] SOKAL, R. R., ROHLF, F. J., *Biometry*, W. H. Freeman, New York (1981).
- [16] BARTLETT, A. C., Radiation-induced sterility in the pink bollworm, ARM-W-1, Agricultural Research Service, U. S. Department of Agriculture, Berkeley, CA (1978).

Poster Presentations

IAEA-SM-301/5P

THE NUCLEAR POLYHEDROSIS VIRUS OF THE FALL WEBWORM, *Hyphantria cunea*, FOR THE DEVELOPMENT OF VIRAL PESTICIDES IN THE REPUBLIC OF KOREA

H.Y. PARK*, J.I. KIM*, K.S. RYOO**, S.K. KANG**

* Genetic Engineering Center,
Korea Advanced Institute of Science and Technology,
Seoul

** Department of Sericulture,
Seoul National University,
Suwon

Republic of Korea

The nuclear polyhedrosis virus (NPV) was isolated from the larvae of the fall webworm, *Hyphantria cunea* (Hc), in the Republic of Korea. The viral properties, histopathological observations of the cells infected with HcNPV, pathogenicity tests and the propagation efficiency of the virus in the larvae were studied for the development of viral insecticides.

The average size of HcNPV polyhedra was 1.8 μm (diameter), with actual sizes ranging from 1.5 to 2.2 μm . Most of them, when viewed under a scanning electron microscope, were tetrahedral or hexahedral in shape, with a few being of irregular shape (Fig. 1). Rod shaped virus particles were embedded in the HcNPV polyhedra (Fig. 2), with 1-17 rods in each envelope. The bundles of rods had an average size of 390 nm \times 50 nm.

At the late stage of HcNPV infection, cytopathic alterations and swelling of infected cell nuclei of the epidermis and fat body tissues were observed by light and electron microscopes (Fig. 3). The viral replication in fat body cells infected with HcNPV was observed as follows: (1) nucleocapsids protruded irregularly from virogenic stroma; (2) there was a regular stacking array of 2-144 nucleocapsids; (3) there was a random release of nucleocapsids from the cluster; (4) nucleocapsids were enveloped; (5) polyhedral proteins were attached to the outer membrane of the enveloped nucleocapsids; and (6) the number of nucleocapsids as bundles in an envelope was 2-17 rods.

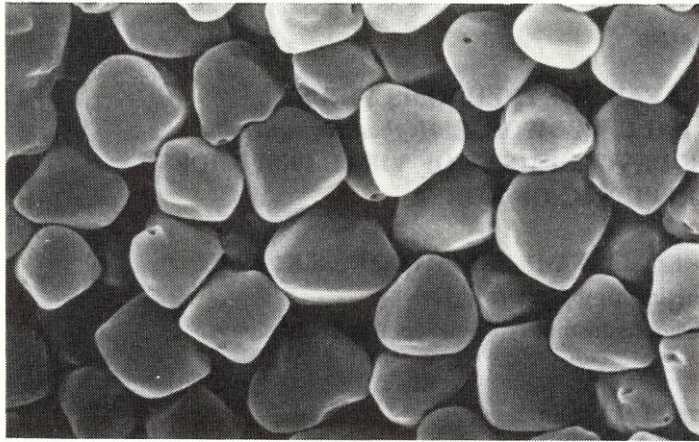

FIG. 1. Purified HcNPV polyhedra observed under a scanning electron microscope.

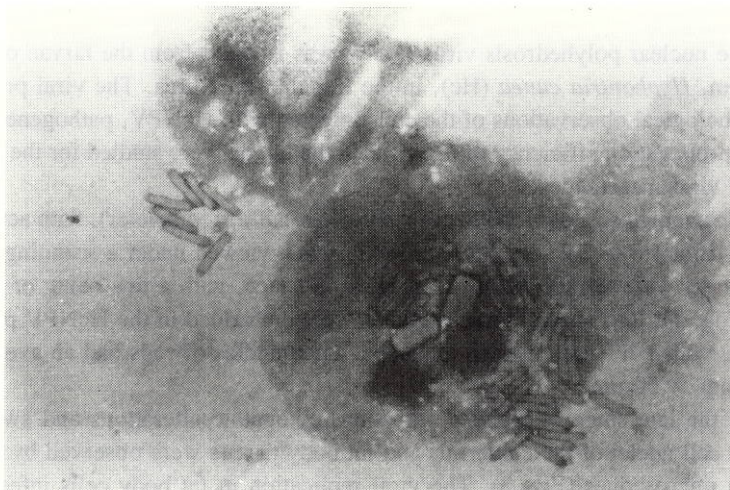

FIG. 2. Alkali liberated viral particles from HcNPV polyhedra.

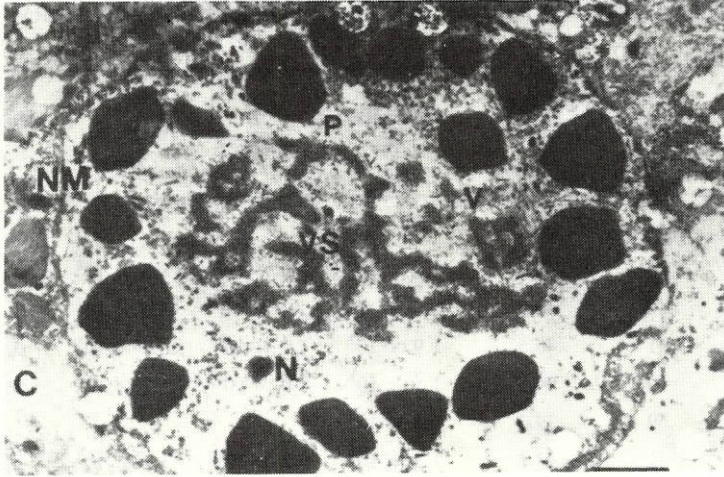

FIG. 3. Completely assembled HcNPV polyhedra in the nucleus of a cell injected with the virus at a late stage of viral infection.

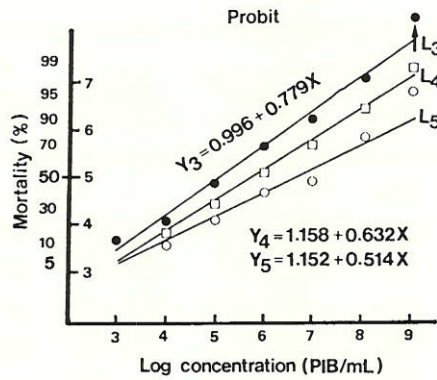

FIG. 4. Dose mortality responses of three Hc larvae following ingestion of different concentrations of HcNPV (arrow indicates 100% mortality).

TABLE I. MULTIPLICATION OF NPV FOR FOURTH INSTAR LARVA OF Hc

PIB conc. (PIB/g wet diet)	No. of test larvae	Feed intake/ larva (mg)	PIB intake/ larva	PIB produced	PIB produced/ larva	Multiplication ratio
<i>Control</i>	40	46.4				
1.5×10^2	38	43.3	1.8×10^0	2.5×10^{10}	8.6×10^8	4.7×10^8
1.5×10^3	40	46.3	2.0×10^1	7.6×10^9	3.6×10^8	1.7×10^7
1.5×10^4	41	45.5	1.9×10^2	1.7×10^{10}	6.2×10^8	3.2×10^6
1.5×10^5	40	34.8	1.5×10^3	4.0×10^{10}	1.2×10^9	8.0×10^5
1.5×10^6	39	39.3	1.7×10^4			
1.5×10^7	41	43.6	1.8×10^5	5.3×10^{10}	1.2×10^9	6.6×10^3

TABLE II. MULTIPLICATION OF NPV FOR FIFTH INSTAR LARVA OF Hc

PIB conc. (PIB/g wet diet)	No. of test larvae	Feed intake/ larva (mg)	PIB intake/ larva	PIB produced	PIB produced/ larva	Multiplication ratio
<i>Control</i>	42	81.3				
1.5×10^2	39	93.6	4.0×10^1	8.5×10^9	4.2×10^8	1.0×10^8
1.5×10^3	40	70.3	3.0×10^1	9.8×10^9	3.5×10^8	1.1×10^7
1.5×10^4	40	55.4	2.4×10^2	4.8×10^9	1.5×10^8	6.2×10^6
1.5×10^5	38	79.7	3.4×10^3	8.6×10^9	2.9×10^8	8.5×10^4
1.5×10^6	40	69.3	3.0×10^4	1.7×10^{10}	4.5×10^8	1.5×10^4
1.5×10^7	39	60.6	2.6×10^5	2.2×10^{10}	5.6×10^8	2.1×10^3

TABLE III. MULTIPLICATION OF NPV FOR SIXTH INSTAR LARVA OF Hc

PIB conc. (PIB/g wet diet)	No. of test larvae	Feed intake/ larva (mg)	PIB intake/ larva	PIB produced	PIB produced/ larva	Multiplication ratio
<i>Control</i>	39	78.9				
1.5×10^2	32	106.1	4.6×10^0	4.5×10^9	3.4×10^8	7.3×10^7
1.5×10^3	37	99.4	4.3×10^1	4.9×10^9	3.0×10^8	6.9×10^6
1.5×10^4	40	72.8	3.1×10^2	4.2×10^9	2.4×10^8	7.7×10^5
1.5×10^5	39	51.3	2.2×10^3	6.7×10^9	2.3×10^8	1.0×10^5
1.5×10^6	40	46.5	2.0×10^4	5.1×10^9	1.7×10^8	8.5×10^3
1.5×10^7	24	107.0	4.6×10^5	5.0×10^9	2.6×10^8	5.6×10^2

In the pathogenicity tests of HcNPV, the median lethal dose 50 (LD₅₀) values were 1.90×10^5 , 1.20×10^6 and 1.85×10^7 polyhedral inclusion bodies (PIB)/mL for, respectively, the third, fourth and fifth instar larvae of *H. cunea* (Fig. 4). Median lethal time 50 (LT₅₀) values were 9.33, 11.29 and 16.5 d for, respectively, the third, fourth and fifth instar larvae of *H. cunea*.

Regarding the mass production of HcNPV in *H. cunea* larvae, the propagation efficiency and biological activities of the virus were not considerably different whether the virus was isolated from larvae reared on an artificial diet or from larvae reared on raw leaves (Tables I-III).

IAEA-SM-301/12P

**CYTOPLASMIC INCOMPATIBILITY
FOR SUPPRESSION OF *Ephestia cautella*
INFESTATION RATE IN SIMULATED
DATE STORES**

M.S.H. AHMED

Faculty of Agriculture and Biology,
Nuclear Research Centre,
Baghdad, Iraq

Two well isolated, small stores were constructed simulating somewhat old country or terminal date stores in Iraq. Ten single walled, commercial standard carton boxes (SCBs), each containing 100 kg of sterilized dates of the 'Zahdi' variety from the 1985 harvest, were placed in the stores. Thirty pairs of strain *Ephestia cautella* 'Baghdad' (B) [1, 2] were then released in store Nos 1 and 2. In addition, 300 incompatible 'American' (A) males were released in store No. 1 containing the 30 pairs mentioned above. This was followed by the introduction of another 300 A males just as the adults started to emerge. One month later, an additional 300 A males were added to store No. 1, with 300 more being introduced after one more month.

Date samples were taken almost monthly from every SCB in the two stores and examined to assess the rates of infestation for a total of five months. The suppression effect of the incompatible males on the percentage of date fruits infested was evident, causing a highly significant decrease in infestation ($P < 0.01$) in store No. 1 throughout the examination intervals, which ranged from 37 to 158 days of storage.

It is believed that continuing releases of incompatible males over several generations might bring about a considerable degree of suppression of infestation. Incompatible males could thus be used in place of radiation sterilized males in the sterile insect technique, since radiation usually lowers the sexual competitiveness of the insects [3]. It is assumed that any single date storage structure can be separately treated, with perhaps one or a few release sites per store, provided that an appropriate *E. cautella* strain can be found [4] having a genetic 'match' with the natural populations [5].

In this respect, strain A males appeared to have a significant influence in bringing about a decrease in the percentage of egg hatch (Table I) of strain B adults, which were caged in containers of three different sizes in the ratios mentioned in the table. Generally, the mean hatching ability of the eggs decreased exponentially, with increasing numbers of A males, in the form $y = ab^x$. Although the effect of container size on the reduction of the egg hatching was statistically not significant, the competitiveness of A and B males at a ratio of 1:1, as calculated by the formula of Fried [6], seemed to increase as the container size increased.

TABLE I. PERCENTAGE HATCH OF EGGS LAID BY *E. cautella* BAGHDAD STRAIN FEMALES MATED WITH B MALES AND CYTOPLASMICALLY INCOMPATIBLE STRAIN A MALES AT THE INDICATED RATIOS AND PLACED IN BEAKERS OF THREE DIFFERENT SIZES

(Figures in parentheses are numbers of replicates)

Numbers of each strain (A:B:B)	Beaker size (L)		
	1.6	3	5
0:5:5	72.26 ^a (10)	64.61 ^a (12)	64.70 ^a (14)
5:5:5	44.10 ^b (7)	33.18 ^b (9)	30.72 ^b (14)
20:5:5	17.38 ^c (7)	21.91 ^{bc} (13)	21.04 ^{bc} (13)
40:5:5	10.04 ^c (6)	15.82 ^c (14)	18.44 ^c (14)

Note: Mean percentages in a column followed by the same superscript letters are not significantly different ($P > 0.05$; Duncan's Multiple Range Test). Means within rows are not significantly different at the level of confidence and with the test mentioned above.

REFERENCES

- [1] AHMED, M.S.H., LAMOOZA, S.B., OUDA, N.A., ALHASSANY, I.A., "Preliminary report on mating studies of three varieties of *Cadra (Ephesia) cautella* Walker", Sterility Principle for Insect Control 1974 (Proc. Int. Symp. Innsbruck, 1974), IAEA, Vienna (1975) 413-422.
- [2] AHMED, M.S.H., et al., J. Stored Prod. Res. **20** 3 (1984) 151.
- [3] BROWER, J.H., J. Stored Prod. Res. **15** (1979) 1.
- [4] LAMOOZA, S.B., et al., in Proc. 4th Scientific Convention of the Iraqi Biological Society, Baghdad, 1977, p. 134 (abstract).
- [5] LACHANCE, L.E., et al., Science **218** (1982) 1142.
- [6] FRIED, M., J. Econ. Entomol. **64** 4 (1971) 869.

GENETIC APPROACHES TO INSECT CONTROL
(Session 3)

Chairman

C.O. CALKINS
United States of America

Invited Paper

ORGANIZATION OF MEDFLY ERADICATION CAMPAIGNS

J. REYES, A. VILLASEÑOR,
A. SCHWARZ, J. HENDRICHS
Programa Moscamed,
Directorate General of Plant Health,
Tapachula, Chiapas,
Mexico

Abstract

ORGANIZATION OF MEDFLY ERADICATION CAMPAIGNS.

Mediterranean fruit fly (medfly) eradication campaigns which incorporate the sterile insect technique in their organizational schemes include two basic technical areas: field operations and sterile fly production. The key elements of a campaign are: (1) the human and financial resources; (2) the working area; (3) the time frame; and (4) the information generated. Each of these elements is divided and organized in such a way as to permit maximum efficiency. To take advantage of all of the resources, these elements are divided into field operations, sterile insect production and administration. Within the field operations category are the resources devoted to detection, control, information and quarantine activities. Included in the sterile fly production phase are mass rearing and maintenance of the insect production process. To maintain an orderly and systematic method of control, the working area and the time frame are divided into equal parts. The information is classified according to technical and operational indices in order to provide a timely and adequate source of information to the campaign head, supervisors and administrators. In planning eradication activities, the 'diversity' of the working area is a key determinant: cost and functionality of the control systems depend on the complexity of the ecosystem, topography and communications facilities. The design of the temporal strategies (stages of progress) and spatial strategies (working areas) must agree with the temporal and spatial distribution of the pest.

1. CAMPAIGN MANAGEMENT STRUCTURE

Since the single objective of a Mediterranean fruit fly (medfly) eradication campaign is the elimination of the pest using the sterile insect technique (SIT), its structure must include two basic technical areas, field operations and sterile fly production. At the staff level, there must be a technical group which advises on the establishment of the general strategies and research plans. A simplified scheme of the organization of an eradication campaign is presented in Fig. 1.

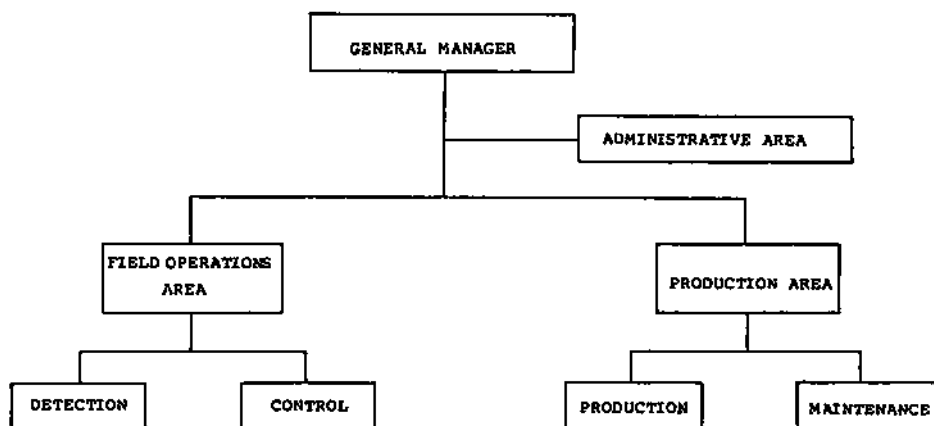

FIG. 1. Simplified framework of a control/eradication campaign using SIT.

2. ORGANIZATION OF FIELD OPERATIONS

The main objectives in creating a field operations area are to ensure (1) timely detection of the wild fly at any biological stage, and (2) control and eradication of detected outbreaks.

Detection activities are carried out by a group comprised of personnel from the trapping and sampling sections. This group is responsible for the planning, establishment and evaluation of a highly effective monitoring system in order to determine the distribution and degree of the temporal and spatial infestation of the pest.

The control activities are carried out by a group consisting of personnel from the chemical and autocidal control sections. When it is required, they also form special 'brigades' for cultural control. This group is in charge of evaluating the methods of controlling wild pest populations and planning their extermination. Finally, they are directly responsible for the eradication of the pest.

In all countries quarantine measures are applied to avoid the spread of many plagues and diseases, regardless of whether or not the medfly is present. For this reason, it is almost certain that a well organized and functioning quarantine service already exists even before the implementation of the medfly eradication campaign. During the campaign period, close co-ordination between them is necessary.

Another activity that is relevant to an eradication campaign is public relations. It has been demonstrated that even when the measures taken to exterminate the pest are efficient, the lack of an effective information system can have a serious impact on planning and the large investments involved, with a consequent increase in the costs of the campaign.

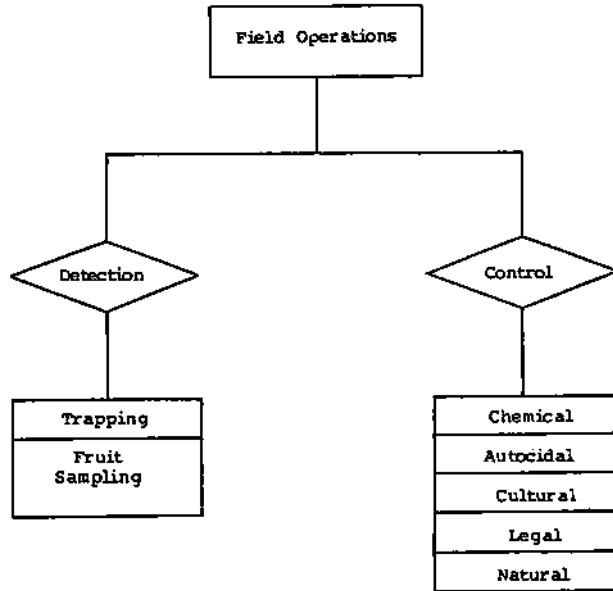

FIG. 2. Different kinds of detection and control systems used in field operations.

Most of the social problems that affect the programme arise as a consequence of the activities carried out by field operations, since these have direct effects on the people and the places where they live. It is therefore absolutely necessary that public relations activities are co-ordinated with activities in the working area. In this way, all detection activities and main control methods used in medfly eradication can be integrated within one working nucleus (Fig. 2).

2.1. Division of the working area

The working area is the 'surface' where each eradication stage is carried out. The division of the working area involves:

- (1) Presentation of results from equal sized surfaces in order to obtain homogeneous data that allow one to make fast comparisons without creating additional data handling.
- (2) Rapid location of the infestations to determine if they are close to or far from a certain reference point (operations centre, landing strips, etc.).
- (3) Keeping a close control over the operation of the detection and control systems.

To accomplish the first point, it is necessary to divide the working area into equal sized quadrants using common conventional co-ordinates, as in cartographic

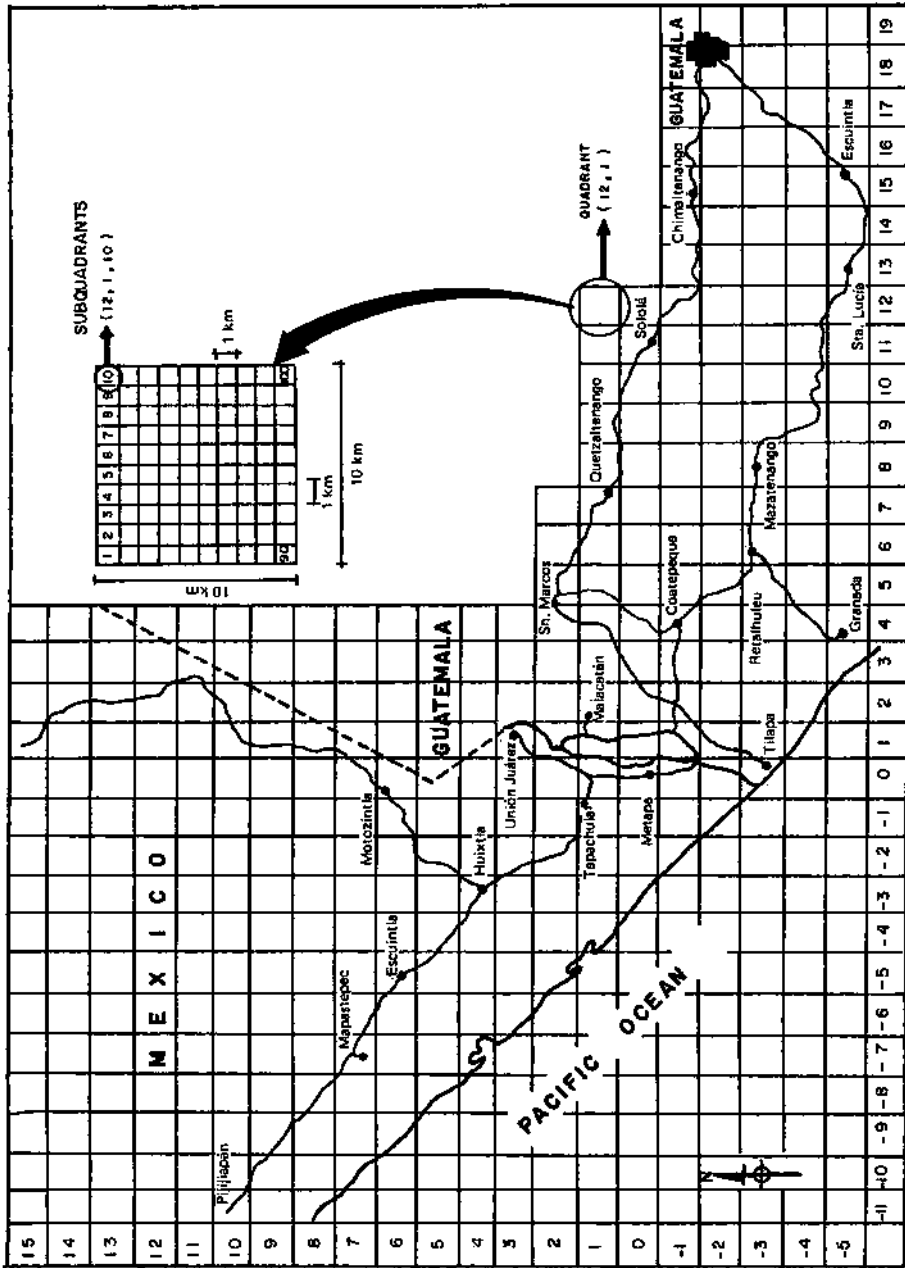

FIG. 3. Working area divided into 100 km² quadrants and 1 km² subquadrants. The codes used to name each of the divisions are also given.

maps. The size of the quadrants will depend basically on the size of the working area. For areas between 2000 and 50 000 km², quadrants of 100 km² (10 km × 10 km) may be used. For larger areas, quadrants of 625 km² (25 km × 25 km), or sectors formed by several quadrants of 100 km² each, may be used.

For rapid location of points of interest (infestations or isolated detections), a key is assigned to each quadrant (using Cartesian co-ordinates). Thus, each quadrant will be identified by two numbers. To make this process faster, subquadrants of 1 km² (1 km × 1 km) may be used. All of the 100 subquadrants formed can be identified by numbers from 1 to 100, following an order by rows. This permits easy location of infestations (Fig. 3).

2.2. Division of the time frame

An advisable practice is to divide the Gregorian year of 365 days into equal sized periods. This permits the handling of results within standard periods. In this way, the data from the working area are more homogeneous and allow rapid calculations to be carried out. The year is thus divided into 13 periods of exactly four weeks each. Using this method, and in spite of having a week with an additional day, easy comparisons can be made without any extra data handling.

If it is necessary to prepare reports which have to be divided by months, such as those intended for the public or requested by governmental organizations, it is recommended, in order to avoid double data recording, that the 13 periods be distributed among the 12 months of the year, including in each month the weeks that have the most days corresponding to the month in question.

2.3. Classifying information

In any working system, information is basic for planning and control, so that its efficient handling becomes a matter of some importance. Information must be true, understandable and timely. Otherwise, serious troubles may arise, troubles which not only reduce efficiency, but also hinder some eradication activities. These will be reflected in the goals that have been set and, finally, in the achievement of the established objectives.

Concerning field operations, information must provide knowledge on two different aspects which have the same importance. The two aspects are pest infestation and its control, and the efficacy of the monitoring and control systems. In order to achieve this, all information is handled through two types of indices: technical and operational. Technical indices measure the level of infestation, or the proportion by which infestation increases or is controlled, as well as the intensity of the measures applied for its control. Operational indices measure the degree of efficiency with which the detection and control methods are applied (Fig. 4).

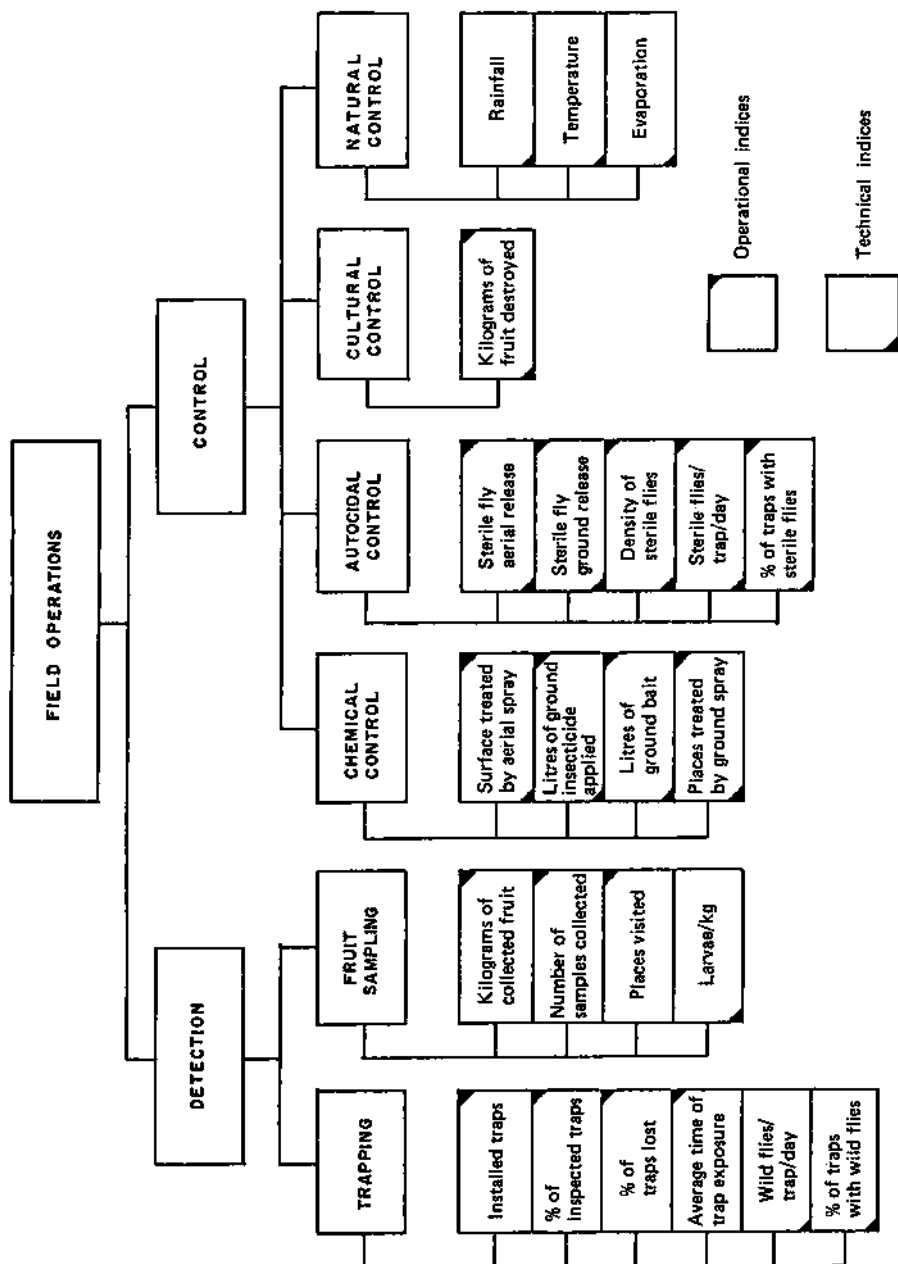

FIG. 4. Key technical and operational indices used in field operations to assess the degree of pest infestation and the operational effectiveness of the campaign.

3. PLANNING OF ERADICATION ACTIVITIES

3.1. Effect of the ecosystem

The medfly is a pest which has a great ability to adjust to many different ecological and climatic environments. Thus, in order to control the medfly, it is necessary to work in different ecological zones, sometimes even within one eradication campaign.

Operation and efficiency of the detection and control systems are affected mainly by the:

- (1) density and complexity of the ecosystem
- (2) topography
- (3) infrastructure or availability of means of communication.

Although the first two may be considered to be natural factors and the third an artificial one, all of them are co-related. It is a common fact that the larger the structural complexity of the ecosystem, or the more uneven the topography, the more limited are the means of communication.

Depending on the degree of ease or difficulty of the field operations activities, the ecological zones in tropical and subtropical regions of Central America may be classified as follows:

- (a) Coastal and midplains
 - cultivated
 - not cultivated,
- (b) Forest and midplains,
- (c) Coffee plantations zone,
- (d) Mid-plateaus and Continental plateaus,
- (e) Mountainous zones.

These ecological zones may be grouped into three basic zones, owing to their similarity, according to the cost and degree of relative progress of each activity in field operations (see Table I).

3.2. Eradication process

In the eradication process there is a logical sequence of stages by which a campaign progresses. These stages are mainly determined by the lack of the pest or the degree of infestation; this is the temporal aspect of the process.

During the eradication process, the working zone is variable and is divided according to the spatial distribution of the infestation.

TABLE I. FEATURES OF THE ECOLOGICAL ZONES IN TROPICAL AND SUBTROPICAL REGIONS WHICH AFFECT AN ERADICATION CAMPAIGN USING SIT

Ecological zone	Type(s) of vegetation	Climate	Annual rainfall (mm)	Temperature (°C)
Cultivated uplands and coastal plains	Cultivated	Tropical-wet	2000-4000	20-30
	Annual crops: banana, cotton, sugarcane, etc.			
Not cultivated	Tropical forest			
Coastal plains and jungle uplands	Tropical forest	Tropical-wet	1500-2000	20-30
Coffee plantations	Coffee, cocoa	Tropical-mountainous	1500-4000	15-20
Continental high plateaus	Annual crops: corn, wheat, grass, etc.	Temperate	500-1000	15-25
Mountainous	Mixed coniferous forests	Mountainous	500-1000	10-20

This temporal-spatial distribution determines the temporal strategies (stages of progress) and the spatial strategies (working areas), which can be summarized as follows:

- (1) infestation
- (2) pre-eradication
- (3) eradication
- (4) post-eradication
- (5) free zone.

Within the working zones, there may exist subdivisions which will depend on the characteristics of the particular zone and on the type of control which is being used. The object of creating these subdivisions is to induce an artificial isolation

TABLE II. PERFORMANCE OF FIELD OPERATIONS ACTIVITIES BASED ON THE WORK ZONE

Activity \ Zone	Post-eradication					
	Free	Buffer	Containment	Eradication	Pre-eradication	Infestation
Detection strategy	Low density trapping	High density trapping	High density trapping	High density trapping	High density trapping	Low density trapping
	Quarantine	Quarantine	High intensity of fruit sampling	High intensity of fruit sampling	Low intensity of fruit sampling	
						Control front 
Control strategy	Use of the contingency plan	Use of the contingency plan	Low density sterile fly releases	High density sterile fly releases	Intensive aerial bait spray applications	
			Some aerial, ground bait spray applications (only for outbreaks)		Intensive ground bait spray applications	

between the different zones in order to avoid reinfestations in the free areas. In each of the stages and/or working zones, the intensity of the detection and control activities depends on the spatial distribution of the pest and the time required to reduce or eliminate the infestation (Table II).

3.3. Emergency plans

In any eradication campaign, it is important to rely on an emergency plan for those areas which are already free of the pest. The plan must indicate clearly the

activities to be carried out to prevent reinfestation and the persons responsible for them.

In those countries which are free of the pest, there are regulations which explain in a general way the quarantine measures established against the pest, or there are plant protection laws. However, when an eradication campaign is started, the total operation of the emergency plan falls within the field operations area. For this reason, one of the first tasks is to prepare an emergency plan. This plan must be updated at least once a year, so that it agrees with the progress reached by the eradication campaign and is suited to the new pest-free zones or areas of strategic importance.

Memoria encargada

PROGRAMA DE ERRADICACION DE LA MOSCA DEL MEDITERRANEO EN GUATEMALA

F. HENTZE
Programa Moscamed,
Ciudad de Guatemala, Guatemala

Abstract-Resumen

MEDFLY ERADICATION PROGRAMME IN GUATEMALA.

The programme on eradication of the Mediterranean fruit fly (*Ceratitis capitata*) in Guatemala has successfully demonstrated that this pest can be eradicated from large areas with the use of the sterile insect technique (SIT), supplemented by a series of control measures. More than 60% of the country is now free of the medfly as a result of the measures taken in the last few years. In the coffee growing areas, the large wild fly populations have been reduced by a factor of more than 1000, in terms of fertile flies per trap per day, and many areas have been totally freed of the pest.

PROGRAMA DE ERRADICACION DE LA MOSCA DEL MEDITERRANEO EN GUATEMALA.

El programa de erradicación de la mosca de la fruta del Mediterráneo (*Ceratitis capitata*) en Guatemala ha demostrado exitosamente la posibilidad de lograr la erradicación de esta plaga de grandes áreas usando la técnica del insecto estéril (TIE), complementada con una serie de acciones de control. Más del 60% del país está actualmente libre de la Moscamed, gracias a las acciones realizadas en los últimos años. En áreas cafetaleras las grandes poblaciones de moscas silvestres han sido reducidas en más de 1000 veces, en términos de moscas fértiles por trampa por día, y muchas áreas han sido totalmente liberadas de la plaga.

1. INTRODUCCION

La mosca del Mediterráneo fue detectada por primera vez en Centroamérica, en 1955, en Costa Rica. Desde allí se dispersó de forma natural a través de Guatemala, alcanzando el sur de México en 1977.

La detección de la mosca del Mediterráneo en Guatemala, en 1975, propició la formación de la Comisión Mixta México-Guatemala para la prevención, control y erradicación de esta plaga. En el año 1977 el Departamento de Agricultura de los EE UU (USDA) se incorporó a la lucha mediante acuerdos bilaterales, y de esta forma se dio origen al Programa Moscamed. Así mismo, se ha recibido apoyo del Organismo Internacional de Energía Atómica (OIEA), tanto en equipo como en asistencia técnica.

Favorecida por las condiciones climáticas y amplia disponibilidad de hospederos, la plaga avanzó en el territorio guatemalteco y mexicano.

Las acciones de control puestas en práctica permitieron, primero, confinar la plaga en la frontera México-Guatemala y, posteriormente, avanzar y desplazar el frente de infestación dentro del territorio guatemalteco.

Actualmente las acciones de erradicación se desarrollan en la región cafetalera guatemalteca, a más de 50 km de la frontera con México en su parte más cercana a la misma.

El Programa Moscamed tiene como objetivos: a corto plazo, detener el avance de la mosca del Mediterráneo hacia el interior de México y los EEUU; a mediano plazo, erradicar la mosca del Mediterráneo de Guatemala; y a largo plazo, erradicar la mosca del Mediterráneo de Centroamérica y Panamá.

2. DIVISION ESTRATEGICA DEL PAIS

De acuerdo con la estrategia de erradicación de norte a sur, la disponibilidad de insectos estériles y la capacidad técnica instalada, el área de acción se dividió en cinco zonas (Fig. 1).

2.1. Zona libre (A)

Es un área libre de la plaga, provista de una red de trapeo estratégicamente localizada con el fin de detectar oportunamente cualquier introducción de la plaga.

Las acciones de detección son más intensas en las áreas que limitan con la zona de post-erradicación. Las detecciones que ocurran en esta zona son ocasionales y totalmente aisladas.

2.2. Zona de post-erradicación (B)

Es un área donde la plaga ha sido erradicada, pero por estar cercana a zonas infestadas es susceptible de reinfestaciones ligeras y continuas, por lo cual está bajo control autocida, con liberaciones de moscas estériles a bajas densidades. El trapeo es utilizado como método de evaluación de las dispersiones de moscas estériles, y el muestreo de frutos es utilizado como método principal de detección de la plaga.

2.3. Zona de erradicación (C)

Es el área donde se realizan de forma intensiva acciones de control, integrando la aspersión de insecticida cebo en forma aérea y terrestre, dispersión de moscas estériles a altas densidades y la destrucción de frutos hospederos; ésta es una zona de avance.

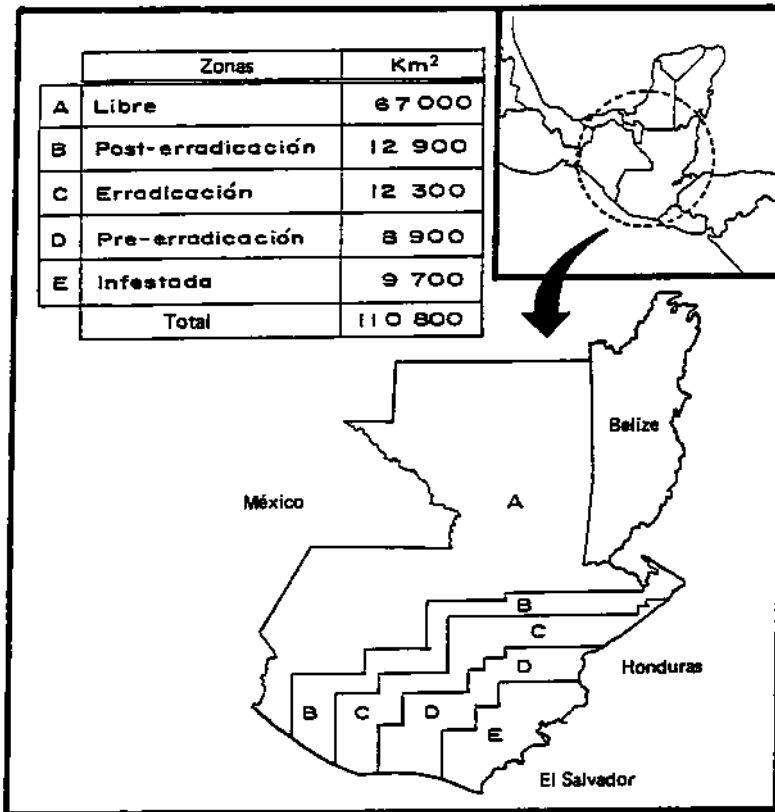

FIG. 1. Distribución de áreas de trabajo en Guatemala.

2.4. Zona de pre-erradicación (D)

Es la zona infestada que se planea erradicar en el siguiente avance; en ella se ejecutan acciones de monitoreo extensivo para determinar la dinámica de población y distribución de la plaga.

2.5. Zona infestada (E)

Es el área en la cual no existe ninguna actividad y que potencialmente se considera infestada.

3. ACCIONES DE DETECCION

3.1. Trampeo

Se utiliza la trampa pegajosa, tipo Jackson, cebada con Trimedlure. El objetivo del trampeo y el número de trampas son diferentes por cada área específica.

CUADRO I. HOSPEDEROS DE MOSCA DEL MEDITERRANEO REPORTADOS EN GUATEMALA HASTA 1987

Nombre común	Nombre científico
Café	<i>Coffea arabica</i> L.
Caimito	<i>Chrysophyllum cainito</i> L.
Naranja agria	<i>Citrus aurantium</i> L.
Naranja dulce	<i>Citrus sinensis</i> Obs.
Mandarina	<i>Citrus reticulata</i> Bco.
Guayaba	<i>Psidium guajava</i> L.
Pera	<i>Pyrus communis</i>
Mango	<i>Manguifera indica</i>
Toronja	<i>Citrus paradisi</i>
Limón mandarina	<i>Citrus</i> sp.
Almendro	<i>Terminalia catappa</i>
Durazno	<i>Prunus persica</i>
Chico	<i>Achras zapota</i>
Níspero	<i>Eriobotrya japonica</i>
Pomarrosa	<i>Eugenia jambos</i>
Manzana	<i>Pyrus malus</i>
Matasano	<i>Casimiroa sapote</i>
Jocote	<i>Spondias purpurea</i>
Lima	<i>Citrus limetta</i> Rizso
Papaya silvestre	<i>Carica</i> sp.
Persimón	<i>Dyospiros decandra</i>
Carambola	<i>Averrhoa carambola</i>
Calamondín	<i>Sargentia gragii</i>
Limón real	<i>Citrus</i> sp.
Lima limón	<i>Citrus</i> sp.
Guanaba	<i>Annona muricata</i>
Nance	<i>Byrsonima crassifolia</i>
Icaco	<i>Chrysobalanus icaco</i>

En áreas clasificadas como "A" (libres de la plaga), se coloca una trampa por cada 3 o 4 km² que se revisa semanalmente. El número de trampas suele ser más alto en el caso de poblados o huertos frutícolas.

En el área "B" (post-erradicación), se coloca una trampa por cada 2 o 3 km².

En el área "C" (erradicación), se coloca una trampa por cada km² en zonas de hospedero continuo (café) y bajo control químico; el número de trampas se reduce a la mitad cuando se inician las liberaciones de insecto estéril.

En el área "D" (pre-erradicación), el número de trampas es bajo, colocándose una trampa por cada 4 o 5 km², con revisión cada dos semanas.

El trapeo se extiende por casi todo el país, formando una red estratégicamente localizada. La colocación de trampas se hace por medio de vehículos de doble tracción, motocicletas, caballos, lanchas, a pie, etc. El número total de trampas oscila entre 30 000 y 40 000.

3.2. Muestreo de frutos

Esta es la técnica de detección y método de búsqueda de la plaga más importante en áreas sujetas a liberaciones de insectos estériles en forma masiva. En áreas donde no se realizan liberaciones de moscas estériles, el muestreo de frutos se lleva a cabo de forma extensiva, para complementar el trapeo. El número de muestras y peso dependen directamente de la disponibilidad de frutos en el campo. Solamente 28 hospederos naturales han sido reportados para Guatemala en más de 100 especies de frutos muestreados, de los cuales el café es el más importante, seguido de la naranja agria, la mandarina, la pera, etc. (véase el Cuadro I).

4. ACCIONES DE COMBATE

Las acciones de combate son el eje de la lucha contra la mosca del Mediterráneo. Su objetivo es combatir y evitar la dispersión de la plaga mediante la implementación de un sistema integrado de control que incluye la aspersión de cebo tóxico por vía aérea y terrestre, la destrucción de frutos hospederos, la liberación de mosca estéril y el establecimiento de medidas de cuarentena.

4.1. Combate químico

El control químico terrestre está diseñado basándose en las condiciones de campo y se aplica para la erradicación de brotes aislados. Las aspersiones aéreas de insecticida cebo son el arma de control más importante en la supresión de las poblaciones nativas y permite una efectiva acción de los insectos estériles para conseguir la erradicación.

La experiencia acumulada en Guatemala en los últimos años ha permitido desarrollar una tecnología de control químico aéreo sobre la Moscamed altamente efec-

tiva, bastante selectiva ecológicamente y de bajo costo económico. El cebo tóxico está compuesto de un 90% de atrayente alimenticio y un 10% de insecticida (Malathion al 91%). La aplicación se realiza en franjas alternas, cubriéndose únicamente un 50% del área con el cebo; la deposición del cebo se hace en gotas gruesas (2-3 mm), colocando de 15 a 20 gotas por 100 cm².

El atrayente alimenticio usualmente usado es la proteína hidrolizada. Sin embargo, durante 1987 se evaluaron adicionalmente y en forma extensiva los siguientes cebos: a) proteína hidrolizada (30%) + melaza de caña de azúcar (20%) + solución de almidón (40%) + Malathion (10%); b) melaza de caña de azúcar (50%) + solución de almidón (40%) + Malathion (10%); y c) proteína hidrolizada (50%) + solución de almidón (40%) + Malathion (10%).

Todos estos cebos funcionaron exitosamente como tóxicos contra la Moscamed, reduciendo las poblaciones nativas en más del 90%. Sin embargo, debe mencionarse que, a nivel de laboratorio, la melaza de caña de azúcar demostró mucha mayor atracción sobre la mosca del Mediterráneo que la proteína hidrolizada. La solución de almidón, que se ha incluido y evaluado en los cebos anteriormente expuestos, estuvo compuesta de un 96% de agua y un 4% de almidón en polvo. Esta solución, cuya consistencia era la de una gel, tuvo dos objetivos en el cebo: 1) proporcionarle cuerpo al cebo tóxico, consiguiendo una mayor proporción de gotas gruesas, así como mejorar la distribución del insecticida dentro del cebo, y 2) reducir los costos haciendo el cebo más económico.

El número de aplicaciones que se lleva a cabo en Guatemala oscila de 4 a 6, con un intervalo de 7 días. Las aspersiones se realizan en áreas extensas cultivadas con café.

En el caso del Malathion, aunque es un insecticida muy efectivo en el abatimiento de la plaga en el campo, se ha planificado una evaluación a gran escala del ácido bórico como una alternativa al Malathion, con el objeto de conseguir un cebo más selectivo para la Moscamed.

Chambers et al. (véase la Bibliografía) han demostrado la potencialidad del ácido bórico como sustituto del Malathion.

4.2. Combate mecánico

El combate mecánico se ha enfocado principalmente a la cosecha y a la destrucción de los principales frutos hospederos, en aquellos lugares donde se han detectado brotes de mosca del Mediterráneo. Su objetivo es la destrucción de huevos y larvas que puedan estar presentes en las frutas en áreas libres de la plaga, evitando así su proliferación.

En el caso de plantaciones grandes de café, el fruto no se destruye, sino que se trata con agua caliente para eliminar los diferentes estados inmaduros de la mosca. Adicionalmente se elimina otra importante plaga del café, la broca (*Hypotenemus hampei*), reduciéndose los niveles de infestación de ésta en la siguiente temporada.

4.3. Combate autocida

Después de haber suprimido las poblaciones nativas de Moscamed usando aspersiones de cebo tóxico, se llevaron a cabo liberaciones masivas de insectos estériles hasta conseguir la erradicación de la plaga. La cantidad de insectos estériles a liberar por semana varía según el tipo de zona (A, B o C), las condiciones ecológicas, los niveles de infestación y la disponibilidad de mosca estéril.

Los insectos estériles se usan básicamente de dos maneras: 1) liberación extensiva, funcionando como barrera biológica para evitar el paso de la plaga de un área infestada y en proceso de erradicación a un área libre de la mosca, y 2) liberación intensiva para erradicar brotes o poblaciones nativas. En el primer caso, las cantidades oscilan entre 500 y 2000 moscas por semana y hectárea y, en el segundo caso, se aplica el modelo de Knipling computarizado, usando una relación de 100 insectos estériles por uno silvestre. Conociendo la eficiencia de la trampa y cómo esta eficiencia es afectada por los factores climáticos, se utilizan las fórmulas siguientes para transformar las moscas por trampa a moscas por hectárea: $E = 0,09523 (T) - 0,001867 (H.R.) - 2,11$ moscas silvestres/hectárea = $(100/E) \times (\text{moscas/trampa/semana})$; donde E es la eficiencia de la trampa, T la temperatura promedio semanal en grados centígrados, y H.R. la humedad relativa promedio semanal.

Conociendo la población absoluta de moscas silvestres, se libera 100 veces más insectos estériles semanalmente y por hectárea, en un área que varía de 50 a 100 hectáreas alrededor de la zona de detección, durante las 10 semanas siguientes.

4.4. Combate legal

Con el propósito de proteger las áreas libres de la plaga, una red de estaciones cuarentenarias se ha colocado en los diferentes aeropuertos, puertos y carreteras que cruzan hacia esas áreas. Diecinueve estaciones operan en Guatemala, desarrollando las actividades de fumigación de vehículos, decomiso y destrucción de fruta y fumigación de fruta con bromuro de metilo.

5. PRODUCCION DE MOSCAS ESTERILES EN GUATEMALA

El laboratorio de cría y esterilización de mosca de la fruta del Mediterráneo en Guatemala inició su actividad de producción de insectos estériles en marzo de 1984. Fue diseñado para producir 100 millones de moscas por semana, bajo el sistema Trunkenpoltz, pero actualmente el laboratorio ha sido agrandado para producir 100 millones más de moscas estériles por semana, éstos últimos bajo el sistema Popping (de Hawai). Esto se ha realizado con el propósito de evaluar qué sistema de producción es el mejor. La dieta para ambos sistemas está compuesta de bagazo de caña de azúcar, afrecho de trigo, levadura de torula, ácido clorhídrico y benzoato de sodio.

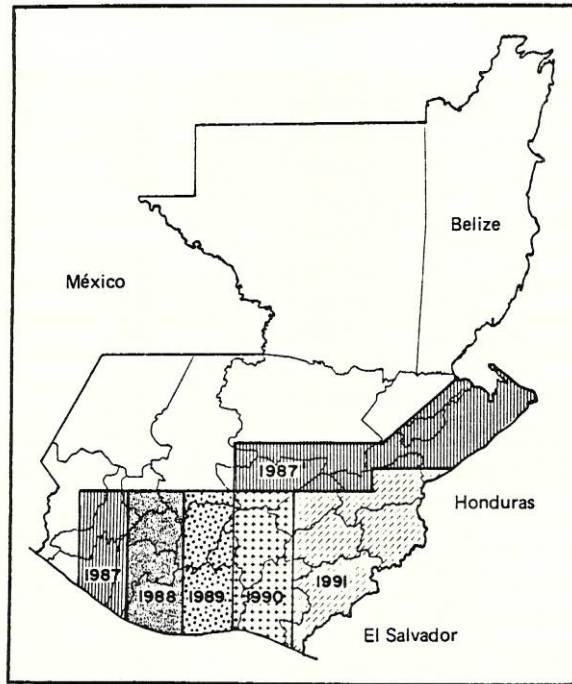

FIG. 2. Proyecto de erradicación de 5 años de duración.

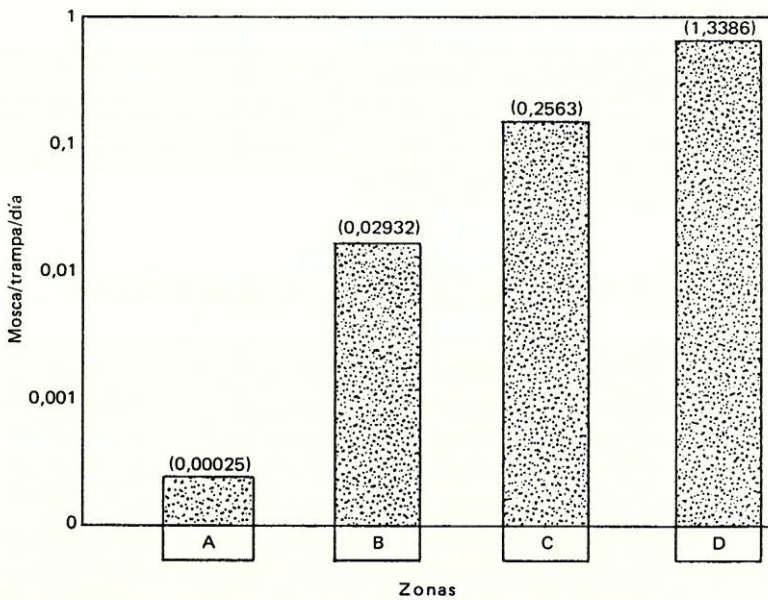

FIG.3. Moscas capturadas por trampa por día en las áreas de trabajo de Guatemala.

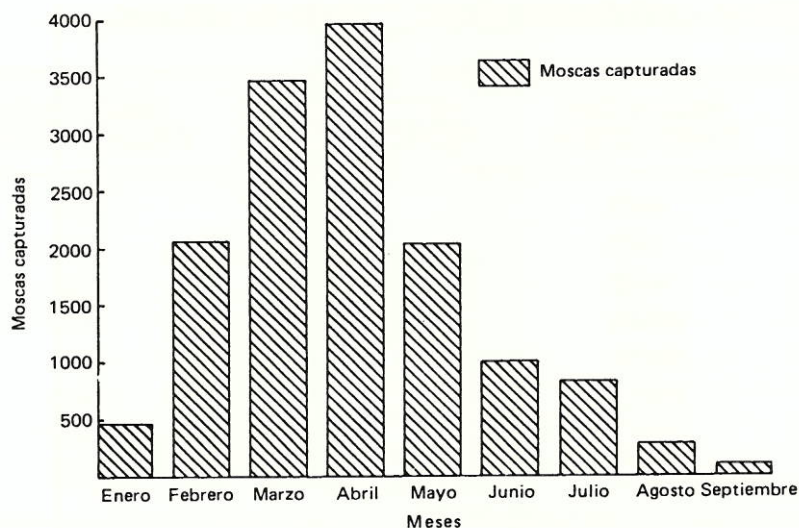

FIG. 4. Decaimiento de la plaga.

6. PROYECTO DE ERRADICACION DE LA MOSCAMED EN GUATEMALA

De acuerdo a la estrategia de erradicación de la Moscamed de Guatemala de norte a sur, se planea un proyecto de erradicación (Fig. 2) de 5 años de duración que depende principalmente de la disponibilidad de insectos estériles. El costo de este proyecto es de cerca de dól. 30 millones.

7. RESULTADOS Y DISCUSION

La técnica del insecto estéril (TIE) ha demostrado ser efectiva para el control y erradicación de la mosca del Mediterráneo en Guatemala. Debido a las altas poblaciones alcanzadas por la plaga en el cultivo del café, es imprescindible realizar aplicaciones aéreas y terrestres de cebo tóxico para reducir las poblaciones nativas a niveles en los cuales el insecto estéril funcione eficazmente.

En la Fig. 3 puede observarse la diferencia en los niveles de infestación en las diferentes zonas de trabajo, demostrándose el efecto de la TIE en la reducción paulatina de las poblaciones hasta conseguirse la erradicación.

Las aspersiones de cebo tóxico se llevaron a cabo en las zonas B (únicamente en brotes) y C (en forma extensiva) con las diferentes combinaciones para formar el cebo atrayente, permitiendo un abatimiento de la población de aproximadamente un 93%. En la Fig. 4 puede observarse el decaimiento de la plaga a partir del mes de abril, cuando se inician las aspersiones aéreas de cebo tóxico.

CUADRO II. ACTIVIDADES DE COMBATE EN GUATEMALA

Año	Combate químico Hectáreas asperjadas	Combate mecánico Tons. fruta destruida	Combate autocida Millones mosca liberada
1980	6 640	—	2 812
1981	3 538	—	2 792
1982	77 628	—	3 124
1983	147 158	32,2	3 848
1984	265 779	942,0	3 917
1985	267 451	1116,4	16 246
1986	405 385	1835,9	19 305
1987 ^a	395 483	2832,4	16 982

^a Al 31 de octubre.

En el Cuadro II pueden observarse los volúmenes de trabajo en términos de hectáreas asperjadas, toneladas de fruta destruida y millones de moscas estériles liberadas por el Programa Moscamed en Guatemala.

Todas estas acciones han permitido cumplir con el objetivo número uno de evitar el desplazamiento de la plaga hacia el interior de México y los Estados Unidos. Así mismo se espera consolidar el programa de erradicación y llevarlo a cabo en los próximos 5 años.

8. CONCLUSIONES

La técnica del insecto estéril es sumamente efectiva en programas de manejo, control y/o erradicación de plagas como la mosca del Mediterráneo.

BIBLIOGRAFIA

- CHAMBERS, D.L., LORRAINE, H., DOWELL, R.V., "Boron as an alternative toxicant in protein bait for Mediterranean fruit flies", *Fruit Flies of Economic Importance (Proc. Int. Symp. Rome, 1987)* (CAVALLORO, R., Ed.), A.A. Balkema, Rotterdam (en prensa).
- HENTZE, F., *Trapping efficiency of Ceratitis capitata W. under different climatic conditions in Guatemala, Programa Moscamed Rep. (1986).*

HENTZE, F., MATA, R., "Mediterranean fruit fly eradication programme in Guatemala", Fruit Flies (Proc. 2nd Int. Symp. Colymbari, Crete, 1986) (ECONOMOPOULOS, A.P., Ed.), Elsevier, Amsterdam (1987).

Programa Moscamed, XX Reunión de Subsecretarios de Agricultura, Mexico-Guatemala-Estados Unidos, Hermosillo, México, Programa Moscamed, Guatemala, 1987.

THE STERILE INSECT TECHNIQUE AND ITS ROLE IN INTEGRATED TRYPANOSOMIASIS CONTROL PROGRAMMES

A.M.V. VAN DER VLOEDT*, J.P. KABAYO**,
E.D. OFFORI*, D. LUGER**

* Insect and Pest Control Section,
Joint FAO/IAEA Division of Isotope and
Radiation Applications of Atomic Energy for
Food and Agricultural Development,
International Atomic Energy Agency,
Vienna

** FAO/IAEA Entomology Unit,
IAEA Seibersdorf Laboratory,
Vienna

Abstract

THE STERILE INSECT TECHNIQUE AND ITS ROLE IN INTEGRATED TRYPANOSOMIASIS CONTROL PROGRAMMES.

In the paper an attempt is made to define the rationale for using the sterile insect technique (SIT) for tsetse fly eradication within the global concept of trypanosomiasis control. Against the background of past and present research and development, and particularly the success of integrated tsetse fly control campaigns in Burkina Faso and Nigeria, the paper identifies problems to be overcome before further major action programmes with an SIT component are undertaken.

1. INTRODUCTION

Tsetse flies (*Glossina* spp.) and the haemoparasites (*Trypanosoma* spp.) they transmit, which cause sleeping sickness in man and trypanosomiasis in livestock, constitute a major threat to human health and cause considerable losses among African cattle. During the last half century, methods of disease and vector control have been developed with the primary goal of disrupting the cycle of disease transmission, or controlling vector populations to keep their detrimental effects at acceptable levels. However, on many occasions, it has been found to be very difficult to implement effective, economic and environmentally acceptable techniques and also ensure a continued disease-free or even low endemicity status in a relatively small proportion of the *Glossina* belt. Broad spectrum practical analysis of vector/disease control and appraisal of the relative merits of some of the control

strategies in the context of African rural development were carried out recently by Jordan [1].

Tsetse flies were the first medically important insects against which genetic methods (i.e. hybridization of closely related species) [2] were directed. The idea of applying the sterile insect technique (SIT) [3] as a method of tsetse fly control was put forward some twenty-five years ago, at a time when it was generally accepted that there was no better alternative to the conventional use of highly effective, persistent insecticides. The idea aroused much enthusiasm, primarily because of the very low reproductive potential of *Glossina*, which, in theory, makes it particularly amenable to control by the principle of induced sterility. This enthusiasm was aroused by the soundness of the basic principles of insect suppression by SIT, as proved by the success of the screwworm fly eradication programme [4, 5] and further strengthened by the growing concern about environmental pollution and the risk of encouraging the development of insecticide resistance. However, this has sometimes generated the false impression that SIT alone is a panacea for the tsetse fly problem, an impression that has never been promoted by the IAEA [6].

It cannot be overemphasized that trypanosomiasis is a very complex tsetse fly borne medical and veterinary problem for which there is no easy solution. The chain of disease transmission between the vectors and the hosts can only be broken effectively and durably by vector control and this can be achieved only by optimal application and integration of all available tools, including trypanocidal drugs [1].

In 1967, the Joint FAO/IAEA Division of Isotope and Radiation Applications for Food and Agricultural Development started its tsetse fly programme with the objective of developing SIT for use, in combination with other environmentally safe methods, in controlling/eradicating selected species of tsetse flies from various parts of Africa whenever it is found to be feasible. The programme, conducted with the participation of scientists from various countries in Africa (Burkina Faso, Ghana, Kenya, Nigeria, Tanzania, Uganda, Zambia and Zimbabwe), Belgium, Canada, Czechoslovakia, France, the Federal Republic of Germany, the Netherlands, Sweden, the United Kingdom and the United States of America, has necessarily involved research and development activities of a varied nature.

What has been achieved so far is the result of the competence and dedication of many scientists and their co-workers in several parts of the world and is proof that international co-operation is more than just a useful concept. It works, provided someone co-ordinates the efforts. Thanks to these joint efforts, considerable progress was made in studying tsetse fly ecology and population dynamics, in developing techniques for mass rearing various species of tsetse fly and in determining the doses of radiation required to adequately sterilize male tsetse flies without adversely affecting their mating and other performance in the field. We have gradually improved our understanding of the genetics, physiology and nutritional preferences of the major species of tsetse fly. In the process, we have accumulated vital information on trypanosome transmissibility and the vectorial capacity of laboratory reared, sterilized males for which safe release strategies were worked out.

2. SIT PILOT TESTS AND OPERATIONAL PROJECTS AGAINST TSETSE FLIES

In comparison with conventional tsetse fly control by means of insecticide spraying, the use of SIT is very recent. This is basically because it was a new technology which required very specific research and development work and, not least, acceptance by decision making bodies before it could be transferred from the laboratory to the reality of field conditions in Africa. In this respect, the pioneer work conducted in Tanzania by a team from the United States Department of Agriculture [7] and in Burkina Faso by the Institut d'Élevage et de Médecine Vétérinaire des Pays Tropicaux-Gesellschaft für Technische Zusammenarbeit (IEMVT-GTZ) teams [8], during their initial pilot research project, has provided baseline information on the operational feasibility of integrating SIT and insecticides, first for control and later for the eradication of *G. morsitans morsitans*, *G. palpalis gambiensis*, *G. tachinoides* and *G. m. submorsitans*. During the second phase of the Burkina Faso programme, the combination of two techniques: reducing wild populations by trapping and using insecticide impregnated screens, and then releasing sterile males, led to the complete eradication of the three tsetse fly species in an agro-pastoral zone in the 'Guinea savanna' of about 3000 km² (more than 650 km of riverine habitat) [9, 10]. These major achievements encouraged the initiation in 1979 of another large scale integrated field project in Nigeria, referred to as BICOT, that, by mid-1987, was well advanced in the eradication of *G. p. palpalis* from a 1500 km² target area. In reference to BICOT, it should be emphasized that its first phase was designed and implemented as a research project, especially since the second species, *G. tachinoides*, was left as an internal control. Thus, no attempts were made to make an impact on trypanosome transmission. However, the outcome of the project activities confirmed that (1) trap/target devices can be economically used for effective suppression of both *G. tachinoides* and *G. p. palpalis*; (2) locally reared and sterilized *G. p. palpalis* males can be effectively deployed to eradicate the target species; (3) releases of sterile males, unlike the use of insecticides, are effective all year round; and (4) insecticide impregnated screens can be effectively used as barriers, especially when re-impregnation is carried out at appropriate time intervals and where there is increasing human activity and community participation in the control operations [11, 12].

The main benefit of the projects referred to above is in providing the justification for further efforts and investments for fine-tuning SIT technology as part of integrated control/eradication programmes, especially to tackle the trypanosomiasis problem in zones with multiple vectors co-existing under a variety of difficult ecological conditions. The feasibility of the integrated control concept, with SIT as a component, has certainly been strengthened by the well documented [13-17] cost effectiveness of odour baited and insecticide impregnated traps and screens.

3. THE FEASIBILITY OF ERADICATION

It is certainly true that the complexity of the tsetse/trypanosomiasis problem, and past experience, should warn against generalized attempts to seek vector population eradication. Many authorities [1] doubt that eradication is possible and others question the wisdom of eradication, or even a high degree of control. In principle, we are inclined to concur with the above points of view, particularly when one takes the following into consideration:

- (1) The many examples of incomplete success or failure of both experimental and large scale insecticide programmes which, in certain zones, suffered from adverse meteorological conditions or where the outcome of the spraying campaign was reinfestation.
- (2) The risk of localized 'over-stocking' beyond the natural 'carrying' capacity of tsetse fly cleared land.

However, when development of the land resources in a tsetse fly infested area constitutes a national priority in the context of improved human and animal health and general socio-economic development, or there are locations where strategic use of trypanocides is not practised, or where chemoresistance has been observed, the option of tsetse fly eradication, and thus trypanosomiasis control, should be considered.

There are certainly a number of tsetse fly infested areas where, in accordance with FAO criteria for tsetse fly control support (i.e. high production potential, proximity to areas with high human population density and competition for land, the technical and economic feasibility of controlling tsetse flies and trypanosomiasis, the national priorities and the prospects of funding for control and development), an integrated tsetse fly control programme with an SIT component could be considered. One of those is the proposed BICOT II area (12 000 km²) in the subhumid zone of Nigeria. Successful elimination of tsetse flies from this area, which encompasses grazing reserves, would significantly accelerate the trend towards increasing pastoral-type settlements and improving animal husbandry and agricultural production [18].

4. IMPEDIMENTS TO THE OPERATIONAL USE OF SIT

We are aware that there is some antagonism as regards the feasibility of tsetse fly control projects with an SIT component and that our belief in the practicability of the concept of mass rearing, release of sterile males and eradication conflicts with opinions expressed by other people with recognized experience in the fields of tsetse flies and trypanosomiasis [1, 19]. In addition to positive criticism (e.g. monospecificity, high investment costs, a relatively long preparatory phase, etc.), uninformed comments were made just as the Tanga research project was terminated, but before

the enlarged Burkina Faso project was successfully completed and before the BICOT project entered its eradication phase against *G. p. palpalis*. In spite of the negative forecasts, the efficacy of the technology has been fully proved and the next step, i.e. area wide eradication through integration of available tools and methods, is worthy of consideration. Certainly, this next step should include further improvements in efficiency and effectiveness by developing improved mass rearing facilities and improved strategies for utilizing the sterile insects in a multispecies habitat.

The mode of reproduction and the nutritional requirements of tsetse flies make their rearing a time consuming and labour intensive enterprise for which an optimal combination of manpower, procedures, equipment, space and environmental requirements is essential. In spite of the tremendous progress that has been made in tsetse fly rearing in the last few years, all existing facilities still lack a reasonable degree of automation or mechanization that would permit a reduction in labour, elimination of human error, improvement of insect quality and an increase in the output of the facility. In addition, it should be emphasized that tsetse fly puparia have almost no shelf storage potential, i.e. storage cannot exceed the normal pupal period and adult males earmarked for release require additional space and handling before being transferred to the field. All of these aspects have serious logistical and financial repercussions which eventually could be alleviated through further research and development work. Other factors affecting the efficiency of the sterile insect release method for tsetse fly have been dealt with in great detail by Curtis [20].

5. OTHER CRUCIAL ASPECTS

As far as the situation in the field is concerned, the first major problem, cited repeatedly by all tsetse fly workers, is the problem of tsetse fly barriers. Indeed, every tsetse fly control or eradication programme faces the same problem of the potential reinvasion of previously cleared areas, especially now that there is sufficient proof of the tremendous flight capacities of tsetse flies [21]. Two options can be considered. (1) The short term barrier, separating the SIT application area from the remaining fly belt. It is moved forward as soon as the highest possible degree of control, and even eradication, has been achieved and a new adjacent area is made ready for treatment. Under West African conditions, the short term barrier can probably best be realized by the Burkina Faso and Nigeria approaches (i.e. a combination of an insecticide impregnated screen barrier, reinforced with biconical traps). (2) The long term barrier separating tsetse fly free areas with a potential for development from the neighbouring fly belt, or from different parts of the same belt. Screens and targets used in an area with community participation will certainly help in the consolidation of the barrier, but a lasting solution can only be offered through rational land utilization and human occupation.

The other major problem we are confronted with is that of trypanosome transmission, and trypanosomiasis in general. Trypanosome transmission is linked to our

concept of control and/or eradication. There is certainly no need to be a 'passionate' eradicator, especially when one considers the effectiveness of strategic chemotherapy and chemoprophylaxis and the importance of the trypanotolerance phenomenon as an alternative method in the fight against animal trypanosomiasis. In our opinion, the only justification for eradicating tsetse flies, i.e. the total extermination of the flies in a geographically defined area, is that they are the major obstacles to socio-economic development, causing recurrent problems if they are not totally eliminated.

As yet, there is insufficient evidence that reducing the tsetse fly population using the appropriate tools, even to one-tenth of its natural density and maintaining it at that level, would decrease very substantially the number of infected animals and, subsequently, decrease the losses and costs involved in diagnosis and treatment. In fact, logic indicates the opposite when one considers the following:

- (1) For all trypanosome species infecting man and domestic animals, animal reservoirs exist [22], the treatment and/or elimination of which is extremely difficult, or is environmentally and morally unjustifiable.
- (2) Shifts from a low endemicity situation to one which is epizootic is in most situations linked more with the trypanosome species, and the virulence of the trypanosome strain, than with tsetse fly density.
- (3) The tsetse fly has a relatively long life. It takes up the infection quite early and remains a source of infection throughout its life. Its survival does not seem to be impaired in any significant way by this life-long trypanosome infection [23, 24].
- (4) The possibility of trypanosome transmission at each probing of the fly, and its very frequent need for a blood meal (on average every two and a half to three days), brings it into regular contact with its human and animal hosts over long periods of time. Furthermore, the presumed necessity of repeated probing by tsetse flies carrying salivarian trypanosomes [25] might influence the rate of vector-host contacts, and thus the probability of infection.

Another point of importance concerns the vectorial capacity of released, sexually sterilized flies. Under laboratory conditions, it has been shown that 'teneral' gamma irradiated tsetse flies can cyclically transmit all major pathogenic trypanosome species as efficiently as can untreated flies [26]. From our own point of view, we see no reason why there should be any difference and this in fact is the reason why both the Nigerian and the Burkina Faso teams have adopted a release strategy in which — after prior suppression of the natural tsetse fly population, including the infected flies — treated males are given at least one blood meal prior to their release, thus avoiding or drastically reducing the risk of propagating *T. brucei*, and eventually *T. congolense*, type infections. As pointed out pertinently by Moloo and Kutuza, large scale releases of sterile males should be preceded by and combined with drug treatment of resident cattle in the target area [26], especially when dealing with a species such as *G. m. centralis* for which it has been proved that non-teneral flies (up to 10%) can establish and mature *T. brucei* type infections [27].

As far as trypanosome transmission in general is concerned, it is still an extremely valuable research option to find out to what extent the compositions of blood and artificial diets determine the ability of the flies to establish and mature particular types of trypanosome infections [28] and to find out if there is any specific genetic constitution of the fly responsible for it, or if this capacity is primarily dependent upon ecological factors influencing the fly during its pupal stage and/or early adulthood. There is already good evidence [29, 30] that it is indeed possible to select and produce strains of tsetse flies that are refractory to trypanosome infection. In the light of the future development of the most practical and safe release strategy, i.e. release of flies treated and released in the pupal stage, this approach merits further efforts and should be explored for various tsetse fly and parasite species.

6. RESEARCH AND DEVELOPMENT AT THE IAEA SEIBERSDORF LABORATORY

The FAO/IAEA Entomology Unit of the IAEA Seibersdorf Laboratory provides research and development support for field projects and co-ordinated research programmes. In addition, essential training in the use of techniques developed for mass rearing and radiation sterilization of the tsetse fly is continuously provided by this unit. Relevant information on research and development conducted during the past three years at the Seibersdorf tsetse fly unit can be summarized as follows.

6.1. Colonization of tsetse flies

The option of multispecies tsetse fly breeding has been chosen to broaden the training programme, enhance comparative studies on reproductive biology, nutritional requirements and radiation sterilization and create a basis for area wide control where different tsetse fly species co-exist.

At present, six species are maintained: *G. p. palpalis* (from Nigeria; maintained since 1974; production 100 000 puparia/month); *G. tachinoides* (from Burkina Faso; maintained since 1984; 10 000 puparia/month; expanding colony); *G. fuscipes fuscipes* (from the Central African Republic; maintained since 1986; 500 puparia/month; experimental colony); *G. pallidipes* (from Kenya; maintained since 1984; 2500 puparia/month; experimental colony); *G. austeni* (from Tanzania; maintained since 1986; 1000 puparia/month; experimental colony); and *G. brevipalpis* (from Kenya; maintained since 1986; 1000 puparia/month; expanding colony).

A highly productive backup colony of *G. p. palpalis* has been maintained and hundreds of thousands of surplus puparia have been sent to Nigeria as an adjunct to the locally produced tsetse flies. Considerable amounts of porcine and bovine blood have been collected, tested and freeze-dried for local use or dispatched for use at the BICOT rearing facilities in Vom, Nigeria.

Since rearing insects for release may comprise up to 60% of the costs involved in an SIT project, constant efforts are made to find more effective and efficient procedures. We have recently developed and successfully used individual cages (PVC frame, 44 cm × 44 cm × 5 cm, with partial partitioning into sectors using perforated metallic strips) which hold 500–600 mated female flies, i.e. a sizeable increase over the normal sized cage, which holds 30 female flies. Also, considerable progress has been made in showing that a variable temperature (21.0–25.0°C) and modified photoperiod cycle within rearing rooms is extremely beneficial in tsetse fly rearing. A stock colony containing 30 000 *G. p. palpalis* females is currently maintained in large cage systems and under modified holding conditions.

6.2. Radiation sterilization

Optimal doses of gamma radiation have been determined for most of the laboratory reared species of tsetse fly. New biological evaluation systems related to induced sterility after treatment of both female and male flies have been developed and their relevance tested to measure the progress of eradication [31].

6.3. Studies of diet

A semidefined synthetic diet for *Glossina* spp. was developed and used successfully to rear *G. p. palpalis* for several consecutive generations [32]. Work now is being directed to efforts to bring down costs. In the present form, the diets remain too expensive to be adopted as viable alternatives. Preparing some dietary ingredients in the laboratory (e.g. haemoglobin and albumin) may help to bring to fruition the promise of an economical, chemically defined diet for the tsetse fly. Already, the most promising diets are being used in nutritional and metabolic studies and in investigations of tsetse flies and trypanosomes at Seibersdorf and other research centres.

Other aspects studied in the context of diet development are:

- (1) Means to improve existing diets (e.g. freeze-dried bovine blood) with emphasis on consistency,
- (2) Correlation of haematological features (e.g. total proteins and lipids in cow and pig blood) with nutrient quality,
- (3) Effect of dialysis on the nutritional quality of blood and blood derivatives [33],
- (4) Utilization of amino acids (¹⁴C labelled) for lipogenesis and 'milk' synthesis,
- (5) Role of iron in the digestion of blood meals (⁵⁹Fe incorporation into haemoglobin),
- (6) Dietary effects on the mycetome symbionts.

6.4. Testing of insecticide formulations

In collaboration with the Joint FAO/IAEA Division's Agrochemicals and Residues Section and its Seibersdorf Laboratory Unit, we have initiated bioassay tests on insecticide formulations. An approach to improving insecticide efficacy is the development of controlled release formulations with the aim of reducing losses of active ingredients through volatilization, photodegradation, etc. A number of insecticides (endosulphan, deltamethrin, cypermethrin) are being tested with the objective of ensuring a long term activity (extending beyond three to four months) on target devices.

7. CONCLUSION

In summarizing the present status of SIT against tsetse flies, it can be stated that many years of research and development work have culminated in operational field work. From a technical point of view, SIT projects in geographically well defined areas of West Africa have been successful. Looking to the future, it would be wise to further develop the SIT approach for use on a regional, rather than individual country, basis. This requires further development of mass rearing systems for handling several tsetse fly species at the same time, as well as development of optimal conditions for long distance transportation of tsetse fly puparia from a regional production centre across international borders. Other investigations should aim to improve sterile male release strategies and monitoring procedures for trypanosomiasis incidence before, during and after vector control activities. No less important requirements are procedures for applying effective quarantines to prevent tsetse flies from reinvading cleared areas. Finally, an area which needs significant improvement in the process of technology transfer and project implementation is management.

REFERENCES

- [1] JORDAN, A.M., *Trypanosomiasis Control and African Rural Development*, Longman, London and New York (1986).
- [2] POTTS, W.H., *Nature (London)* **154** (1944) 606-607.
- [3] KNIPLING, E.F., *J. Econ. Entomol.* **48** 4 (1955) 459-462.
- [4] KNIPLING, E.F., *Smithsonian Rep. Pub.* 4365 (1958) 409-418.
- [5] KNIPLING, E.F., *United States Department of Agriculture Handbook ARS-38-98* (1964) 54.
- [6] Application of sterility principle for tsetse fly suppression. Review of a Panel, *At. Energy Rev.* **10** 1 (1972) 101-130.
- [7] CUISANCE, D., POLITZAR, H., GIDEL, R., CLAIR, M., Report, Centre de recherches sur les trypanosomoses animales, Bobo-Dioulasso, Burkina Faso (1981) 35.
- [8] WILLIAMSON, D.L., DAME, D.A., COBB, P.E., BAKULI, B., WARNER, P.V., *Bull. Entomol. Res.* **73** (1983) 391-404.

- [9] MÉROT, P., POLITZAR, H., TAMBOURA, I., CUISANCE, D., *Rev. Elev. Méd. Vét. Pays Trop.* **37** 2 (1984) 175-184.
- [10] CUISANCE, D., POLITZAR, H., MÉROT, P., TAMBOURA, I., *Rev. Elev. Méd. Vét. Pays Trop.* **37** 4 (1984) 449-467.
- [11] OLADUNMADE, M.A., TAKKEN, W., DENGWAT, L., NDAMS, I., *Bull. Entomol. Res.* **75** (1985) 275-281.
- [12] TAKKEN, W., et al., *Bull. Entomol. Res.* **76** (1986) 275-286.
- [13] LAVEISSIERE, C., COURET, D., *Cah. ORSTOM, Ser. Entomol. Méd. Parasit.* **19** 4 (1981) 271-283.
- [14] LAVEISSIERE, C., COURET, D., HERVOUET, J.P., EOUZAN, J.P., Report IRTO No. 1/RAP/84, Organisation de coordination et de coopération pour la lutte contre les grandes endémies/IRTO (1984) 29.
- [15] HARGROVE, J.W., VALE, G.A., *Bull. Entomol. Res.* **68** (1978) 607-612.
- [16] VALE, G.A., *Bull. Entomol. Res.* **70** (1980) 563-570.
- [17] VALE, G.A., HALL, D.R., *Bull. Entomol. Res.* **75** (1985) 219-231.
- [18] FERGUSON, W., BICOT II -- Project Preparation Mission, FAO Report, FAO, Rome (1987).
- [19] MOLYNEUX, D.H., et al., "Perspectives in trypanosomiasis research", *Recent Advances in Tropical Medicine* (GILES, H.M., Ed.), Churchill Livingstone, Edinburgh and London (1984) 85-102.
- [20] CURTIS, C.F., "Factors affecting the efficiency of the sterile insect release method for tsetse", *Isotope and Radiation Research on Animal Diseases and Their Vectors* (Proc. Int. Symp. Vienna, 1979), IAEA, Vienna (1980) 381-396.
- [21] CUISANCE, D., FÈVRIER, J., DEJARDIN, J., FILLEDIER, J., *Rev. Elev. Méd. Vét. Pays Trop.* **38** 2 (1985) 153-172.
- [22] MEHLITZ, D., ZILLMANN, U., SACHS, R., Report, Scientific, Technical and Research Commission of the Organization of African Unity, Lagos (1986).
- [23] DUKE, L.A., *Ann. Trop. Med. Parasitol.* **22** (1928) 25-29.
- [24] BAKER, J.R., *East African Trypanosomiasis Research Organization Annual Report, July 1956-December 1957.*
- [25] JENNI, L., MOLYNEUX, D.H., LIVESEY, J.L., GALUN, R., *Nature (London)* **283** (1980) 383-385.
- [26] MOLOO, S.K., KUTUZA, S.B., *Insect Sci. Appl.* **5** 5 (1984) 411-414.
- [27] MOLOO, S.K., et al., in Proc. 18th Mtg of the International Scientific Council for Trypanosomiasis Research and Control, Harare, Zimbabwe, 1985, Scientific, Technical and Research Commission of the Organization of African Unity, Lagos.
- [28] MAUDLIN, I., KABAYO, J.P., FLOOD, M.E.T., EVANS, D.A., *Z. Parasitenkd.* **70** (1984) 11-19.
- [29] MAUDLIN, I., *Ann. Trop. Med. Parasit.* **76** (1982) 225-227.
- [30] MAUDLIN, I., *Parasitol. Today* **1** (1985) 59-60.
- [31] VAN DER VLOEDT, A.M.V., BARNOR, H., *Insect Sci. Appl.* **5** (1984) 431-437.
- [32] KABAYO, J.P., TAHER, M., VAN DER VLOEDT, A.M.V., *Bull. Entomol. Res.* **75** (1985) 635-640.
- [33] KABAYO, J.P., TAHER, M., *J. Insect. Physiol.* **32** 6 (1986) 543-548.

Invited Paper

EPIDEMIOLOGICAL SURVEY IN THE PASTORAL ZONE OF SIDERADOUYOU, BURKINA FASO

B. BAUER, J. PETRICH-BAUER, I. KABORÉ, B. KOUROUMA,
M. MATTAUSCH, J. SOMÉ, I. TAMBOURA

Centre de Recherches sur les Trypanosomoses Animales-
Gesellschaft für Technische Zusammenarbeit (CRTA-GTZ)

Project Glossines,
Bobo-Dioulasso,
Burkina Faso

Abstract

EPIDEMIOLOGICAL SURVEY IN THE PASTORAL ZONE OF SIDERADOUYOU, BURKINA FASO.

The pastoral zone of Sideradougou, Burkina Faso, covers approximately 3500 km². An integrated campaign against three tsetse fly species (*Glossina palpalis gambiensis*, *G. tachinoides* and *G. morsitans submorsitans*) was started in 1981. A population reduction of between 88 and 93% was achieved by the use of insecticide impregnated screens. After the initial reduction, massive and continuous releases of sterile males led to a further decrease in the tsetse fly population. Reinvasion was prevented by means of barriers consisting mainly of insecticide impregnated screens and traps along the principal river systems. In the case of *G. m. submorsitans*, a total of ten lines of traps and screens were placed on both sides of the Koba River. The barriers along the rivers had a length of about 10 km, traps and screens were installed at intervals of 100 m. Eradication of all tsetse fly species was achieved during 1985. Since then the barriers have been maintained to prevent reinvasion by the tsetse flies. Regular checks, at bimonthly intervals, have so far confirmed the success of the eradication campaign, the barriers proving effective in preventing reinvasion. An epidemiological survey was initiated almost two years after eradication. Three hundred and fifty-six bovines, 6-12 months old, from different project sites, were chosen and marked with ear tags. Three hundred and fifty bovines of the same age, from outside the pastoral zone of Sideradougou in areas of varying tsetse fly densities, were chosen as well and marked in a similar fashion. The epidemiological survey started in August 1986 and ended in June 1987. The blood of all of the animals was examined using an improved haematocrit centrifugation technique (in the presence of Walker's solution) to detect pathogenic trypanosomes (*Trypanosoma vivax*, *T. congolense* and *T. brucei*) at intervals of four to six weeks. The packed cell volume and weight development were other parameters that were closely followed during the observation period. Serological samples were collected at intervals of three months to detect antibodies against pathogenic trypanosomes. A few cases of *T. vivax* infections were found in some bovines within the pastoral zone of Sideradougou, though mechanical transmission by biting flies (*Tabanids* and *Stomoxys* flies, for example) could not be excluded. However, numerous infections with all species of pathogenic trypanosomes were identified outside the project area. The results indicate that the barriers described here are effective in preventing reinvasion by tsetse flies after their successful eradication.

1. INTRODUCTION

The pastoral zone of Sidéradougou comprises approximately 3500 km² and is situated in the south-west part of Burkina Faso (Fig. 1). An integrated campaign against three tsetse fly species, i.e. *Glossina palpalis gambiensis*, *G. tachinoides* and *G. morsitans submorsitans*, was started in 1981. This work was financed and conducted by the Gesellschaft für Technische Zusammenarbeit (GTZ) and the Institut d'Élevage et de Médecine Vétérinaire des Pays Tropicaux (IEMVT), with the technical assistance of the Government of Burkina Faso, collaborating through an organization designated as the Centre de Recherches sur les Trypanosomoses Animales (CRTA).

After preliminary entomological surveys, approximately 7000 insecticide impregnated screens were installed over a period of three months. This resulted in a reduction in the natural tsetse fly population of between 88 and 93%. The screens were then withdrawn and this was followed by continuous release of sterile males. The males were produced in a mass rearing facility at CRTA in Bobo-Dioulasso [1]. Prior to their release, all of the males were individually labelled and then irradiated using a ¹³⁷Cs source. Barriers consisting of traps and screens were established before and during the campaign along the principal river systems. Repeated entomological checks over the course of 1984 revealed that the *Glossina* spp. had been eradicated [2]. This was confirmed by an expert from the Food and Agriculture Organization of the United Nations. With the exception of some peripheral foci along the escarpment between Bobo-Dioulasso and Banfora, the maintenance of the barriers since the end of the campaign has successfully prevented reinvasions by tsetse flies.

2. MATERIALS AND METHODS

An epidemiological survey was initiated almost two years after eradication. Within the pastoral zone, five sites were chosen: Dingasso, Nyarafo, Moussobadougou, Noumousso and Ouara (see Fig. 1). A total of 356 bovines, 6–12 months old, were labelled with ear tags. Of the selected animals, approximately 52% were cross-bred (Zebu × Baoulé), 47% were Zebu and only 1% were Baoulé. Figure 1 also shows three control sites outside of the pastoral zone: Kassandé, Kouèré and Satiri. Three hundred and fifty bovines of the same age were selected, and their ears were similarly labelled. In Kassandé, 43% of the animals were cross-bred, while 37% were Baoulé and 20% were Zebu. The Baoulé dominated in Kouèré, with 93%, followed by 5% cross-bred and only 2% Zebu. On the other hand, Satiri showed a clear dominance of Zebu (96%), while the remaining 4% were cross-bred; this may be due to the fact that the cattle owners belong to the Fulani tribe originating from the northern parts of Burkina Faso. Further south, in the region of Kouèré, most of the cattle owners are autochthones.

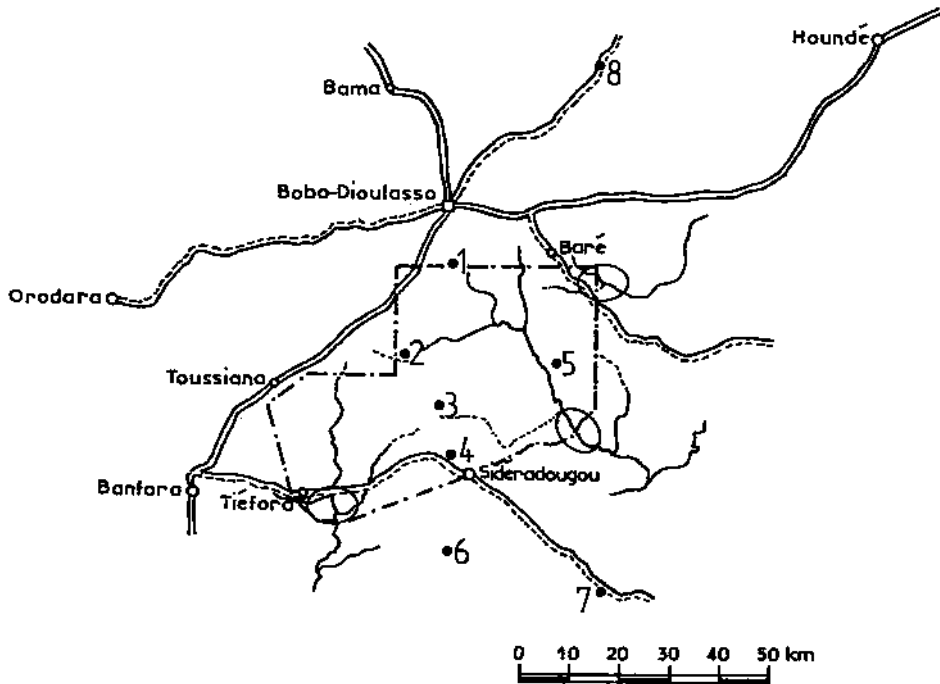

FIG. 1. The pastoral zone of Sidéradougou, Burkina Faso. The sites at which the epidemiological survey was carried out were: Dingasso — 1; Nyarafo — 2; Moussobadougou — 3; Noumousso — 4; Ouara — 5. The control sites outside the pastoral zone were: Kassandé — 6; Kouéré — 7; and Satri — 8. ○ : barriers.

At the beginning of the survey all animals received a single treatment with diminazene aceturate (3.5 mg/kg by weight) and ivermectine (0.2 mg/kg by weight). The survey started in August 1986 and ended in June 1987. Blood samples were taken from all animals at intervals of six to eight weeks. At the same time, the thoracic perimeter of each individual was recorded. The blood samples were examined using the haematocrit centrifugation technique [3] and the capillary concentration technique [4]. The packed cell volume (PCV) was recorded and serological samples were taken at three month intervals. Bovines showing African animal trypanosomiasis (AAT) were treated with 7 mg/kg by weight of diminazene aceturate. Other diseases, such as bacterial infections or internal parasites, were treated with antibiotics and anthelmintics if it was thought to be necessary. The removal of ear tags and sale, death and migration further south caused the loss of many labelled animals. For the evaluation of the results, only those bovines were taken into account that were available at least three times during the investigation period.

3. RESULTS AND DISCUSSION

Figures 2-9 summarize the prevalence of AAT and the mean PCV levels of the labelled bovines at the different sites. Within the pastoral zone, the development of the mean PCV values followed a similar pattern. With the exception of Mous-sobadougou, the mean PCV values increased distinctly during examination II. The injection of diminazene aceturate and/or ivermectine could be the cause for this improvement. A similar phenomenon was observed in cattle treated with diminazene aceturate in the Côte d'Ivoire [5]. As in every year, the effects of the dry season (October-May) caused a deterioration in the nutritional status of the cattle. Bush fires destroyed vast pasture areas and water holes dried out. The insufficient amount of food and the lack of water forced cattle owners to cover longer distances with their animals in order to cope at least partially with their nutritional needs. Hence the mean PCV level was lowest during examinations IV and V, i.e. in March and April. The onset of the rainy season in May improved the nutritional situation for the cattle, resulting in a slight increase in their mean PCV values during examination VI, reaching a peak during the last examination in June 1987. In Ouara, however, a high infection rate with *Trypanosoma vivax* (31%) probably prevented a more distinct increase in the mean PCV level (Fig. 6). The infection was acquired outside the pastoral zone. Lack of water and pasturage had forced the cattle owners to leave the pastoral zone in a south-eastern direction, thereby penetrating into the *G. m. submorsitans* belt.

No case of AAT was detected in the cattle of Mous-sobadougou and Noumousso, and in Nyarafo only one animal showed an infection of *T. vivax* during examination VI (Figs 3-5). In Dingasso, the infection rate with *T. vivax* was relatively high between examinations III and V, ranging from 4.4% to 9.4% (Fig. 2), though mechanical transmission could not be excluded in the first instance. Biting flies, e.g. *Tabanids* and *Stomoxys* flies, were frequently caught at all sites. Still, the overall infection rate remained negligible throughout the epidemiological survey provided the cattle did not leave the pastoral zone. In previous years, peripheral reinvasions by tsetse flies were observed along the escarpment between Bobo-Dioulasso and Banfora. The fly activity was highest during December and January when bush fires frequently destroyed the vegetation. At the foot of the escarpment permanent springs and dense, evergreen vegetation had formed ideal resting sites for invading tsetse flies. In the search for a possible explanation for the increase in the infection rate, biconical traps were installed around the springs that were used as a watering place for the cattle. During a 24 h period, nine *G. tachinoides* were caught in a total of 30 traps. One fly had a mature infection with *T. vivax*. The use of insecticide impregnated screens at intervals of 25-50 m rapidly cleared up the reinvasion. In subsequent entomological surveys, no more tsetse flies could be detected. The infection rate of the cattle dropped to 1.5% in the following investigations.

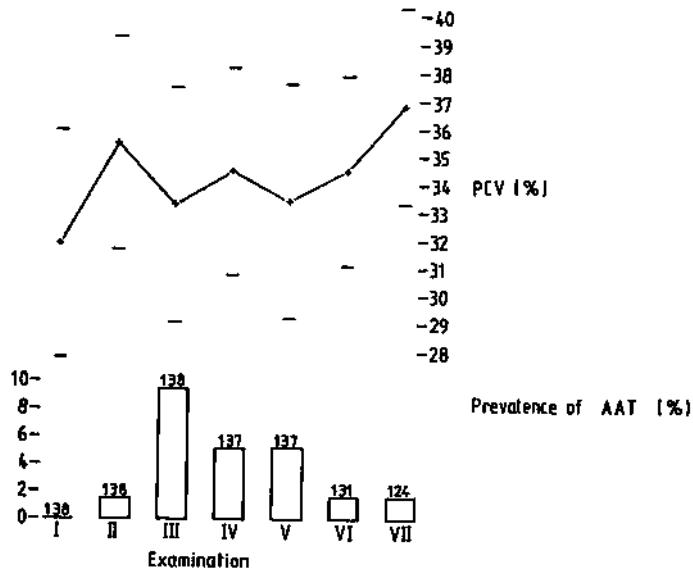

FIG. 2. Prevalence of AAT and the mean PCV levels of labelled bovines at Dingasso, August 1986 - June 1987 (□: *T. vivax*).

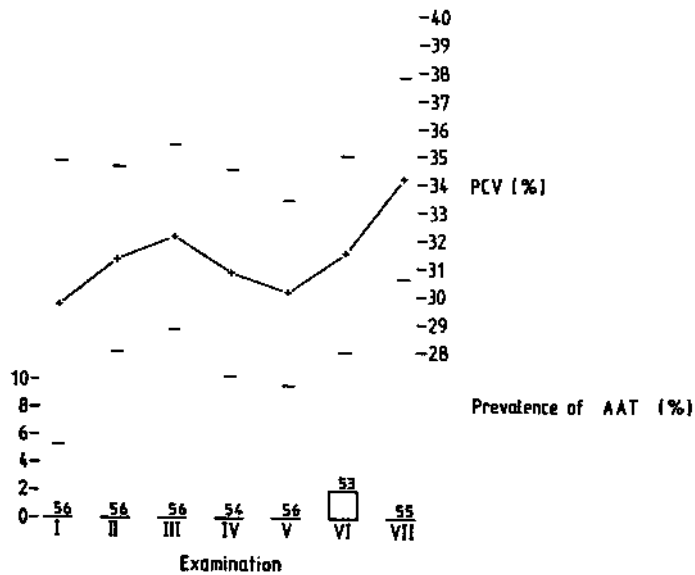

FIG. 3. Prevalence of AAT and the mean PCV levels of labelled bovines at Nyarafa, August 1986 - June 1987 (□: *T. vivax*).

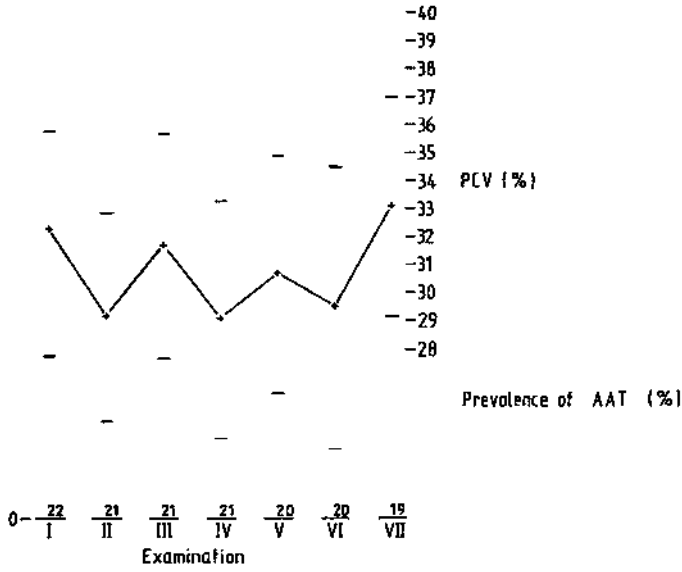

FIG. 4. Prevalence of AAT and the mean PCV levels of labelled bovines at Moussobadougou, August 1986 - June 1987.

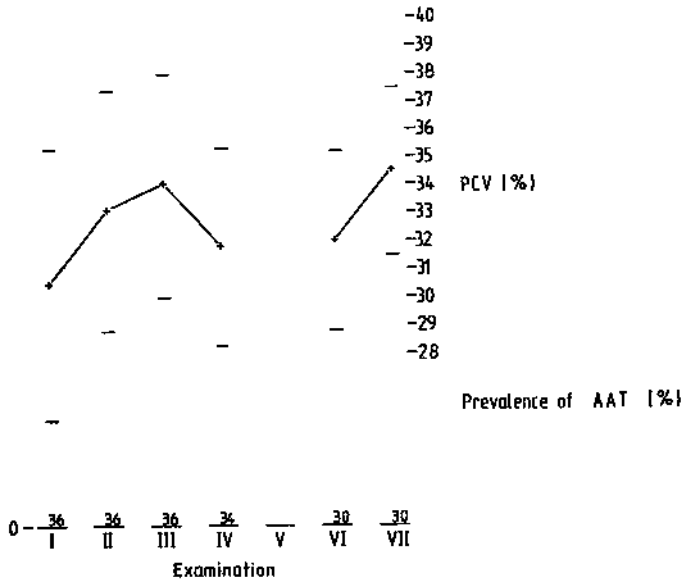

FIG. 5. Prevalence of AAT and the mean PCV levels of labelled bovines at Noumouso, August 1986 - June 1987.

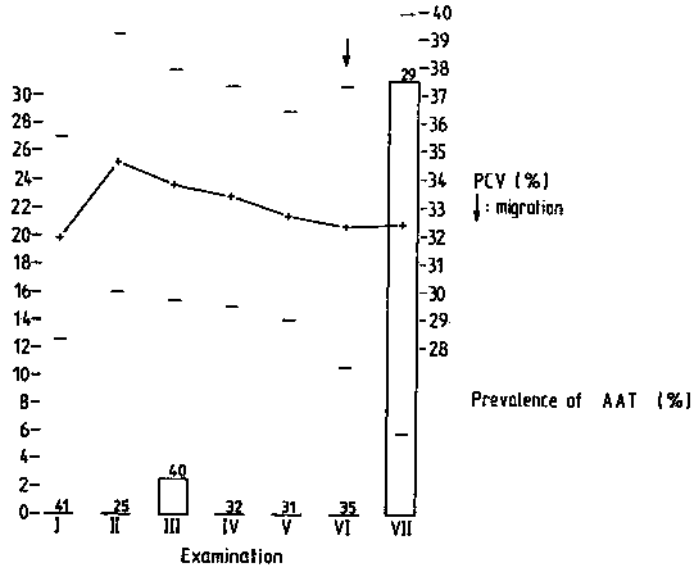

FIG. 6. Prevalence of AAT and the mean PCV levels of labelled bovines at Ouara, August 1986 - June 1987 (□: *T. vivax*).

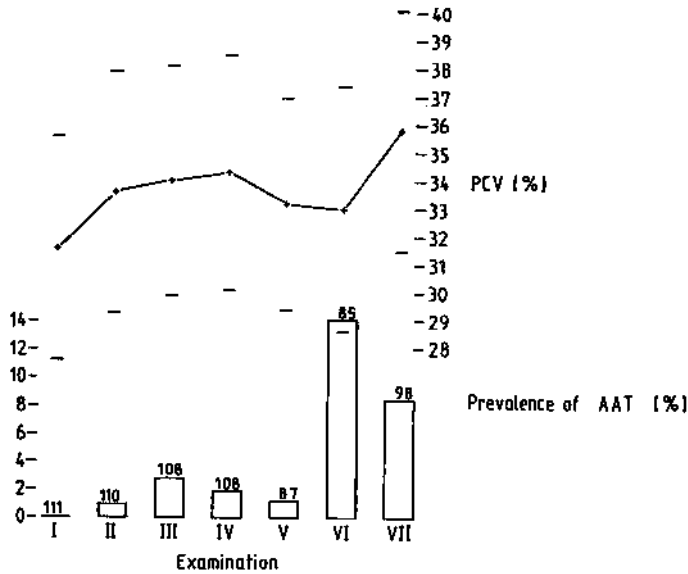

FIG. 7. Prevalence of AAT and the mean PCV levels of labelled bovines at Kassandé, August 1986 - June 1987 (□: *T. vivax*).

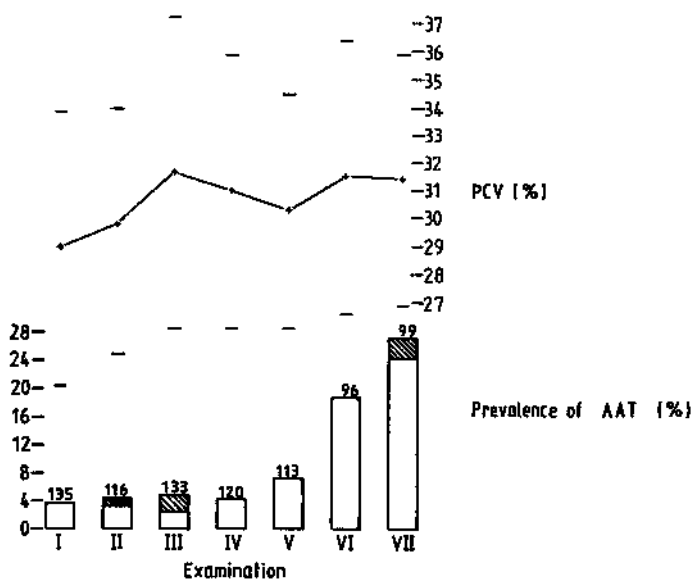

FIG. 8. Prevalence of AAT and the mean PCV levels of labelled bovines at Kouèré, August 1986 - June 1987 (□: *T. vivax*; ▨: *T. congolense*).

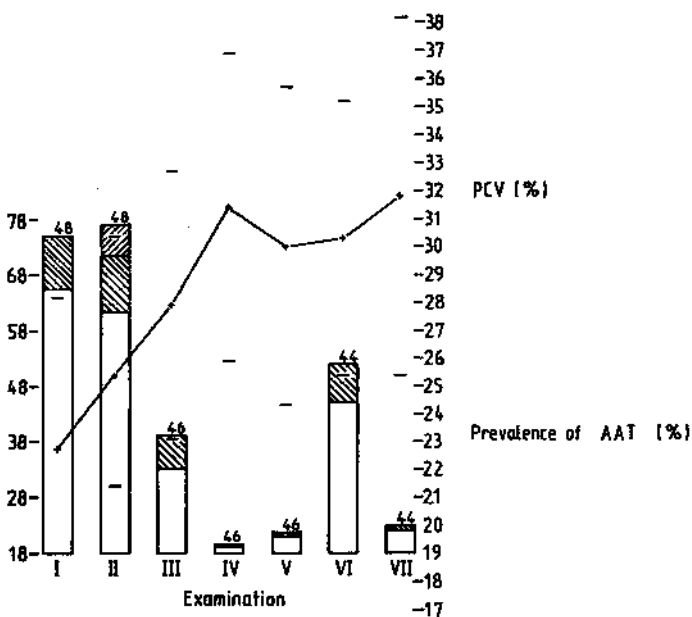

FIG. 9. Prevalence of AAT and the mean PCV levels of labelled bovines at Satiri, August 1986 - June 1987 (□: *T. vivax*; ▨: *T. congolense*; ▩: *T. brucei*).

Figure 7 summarizes the results obtained at the first control site. The region of Kassandé is intensively cultivated, with the greater part of the original vegetation, as well as the fringing forests, along the rivers having been destroyed. These rivers usually dry out during March–May every year. However, there is no need for cattle owners to undertake frequent migrations with their livestock because the watering places and pasturage are almost sufficient throughout the year. The *Glossina* spp. do not occur in this region and it is only at the end of the dry season that lack of water forces a migration further south to permanent rivers which are infested with *G. p. gambiensis* and *G. tachinoides*. This was confirmed by the results of the epidemiological survey which, during the first five examinations, found the prevalence of AAT to be low (0–2.8%). The infection rate rose sharply during examinations VI and VII: 14.1% and 8.2%, respectively, of the bovines were infected with *T. vivax*.

The results obtained at Kouèré are presented in Fig. 8. At this control site, the two riverine species and *G. m. submorsitans* occurred in numbers that were difficult to detect during the rainy season and the beginning of the dry season (October and November). As in Kassandé, the prevalence of AAT was relatively low during the first five examinations (3.5–6.2%). A significant increase in the infection rate was recorded in examination VI (17.7%). The maximum value of 27.3% was found in the last examination. As is the case in Kassandé, the lack of water forced the cattle owners to penetrate into areas with permanent watering places (rivers) where the 'fly pressure' was higher. Infections with *T. vivax* were still dominant but, in contrast to the prevailing results, *T. congolense* was detected in some bovines as well (0.9–3.0%). Apparently, the overall infection rate at Kouèré was even higher. Some of the Baoulés that tested positive escaped before they could be treated with diminazene aceturate, but during the following examination the parasitaemia in these bovines was not detectable and their PCV level had even improved. Treatment with trypanocides in the meantime could be excluded. Presumably, some of the Baoulés succeeded in controlling the level of parasitaemia to such an extent that detection with the described techniques was difficult. Previous attempts had shown that it was difficult to detect infections with a parasitaemia of less than 1000 trypanosomes/mL.

Satiri was characterized by a relatively high tsetse fly density. *Glossina palpalis gambiensis*, *G. tachinoides* and *G. m. submorsitans* were frequently caught. For instance, ten biconical traps sometimes caught more than 100 tsetse flies during two hours of trapping in the morning. *Glossina palpalis gambiensis* was dominant in the catches, followed by *G. tachinoides* and, finally, *G. m. submorsitans*. The favourite habitat for all three tsetse fly species was the fringing forest along the river which, apart from some patches, had dried out during the dry season. As can be seen in Fig. 9, the prevalence of AAT was very high throughout the entire survey period. Apparently, a dose of 3.5 mg/kg by weight of diminazene aceturate was insufficient to cure the infection. Of the bovines tested, 74.0% were positive during examination I. In spite of the treatment, the infection rate rose to a maximum of 77.1% in examination II. Consequently, the curative dose of diminazene aceturate was doubled (7 mg/kg by weight). This dose caused a drop to 39.1% after treatment of all labelled animals.

Throughout the epidemiological survey, the prevalence of AAT remained high in Satiri. Even with close surveillance, i.e. at intervals of four weeks between the examinations instead of six to eight weeks as for all of the other sites, the infection rate varied between 19.6% and 52.3%. Found at the site were *T. vivax* (still dominating), *T. congolense* and *T. b. brucei* (only after inoculation in mice). As a result of the close veterinary surveillance, the mean PCV level increased from 22.7% to 31.8% at the end of the epidemiological survey.

With respect to its accuracy, the assessment of weight based on the measurement of the thoracic perimeter is not satisfactory. Yet, a consecutive recording of all measurements over a period of ten months permitted recognition of trends in the evolution of the weights of the labelled animals. In spite of the increasing agricultural activities reducing pasturage, the weight gain was highest within the pastoral zone: Nyarafo recorded 45.1%, Noumousso 44.4% and Moussobadougou 38.0%. On the other hand, even with pasturage of high quality, the maximum weight increase outside the pastoral zone was found in Kouèré (32.1%), whereas in Satiri the gain was only 23.9%.

4. CONCLUSIONS

Along the eastern, south-eastern and southern boundaries barriers prevented a reinvasion by tsetse flies. In the north-west, peripheral reinvasions from tributaries of the Comoé and the Kou at the upper part of the escarpment resulted in increased infection risk to herds grazing at the foot of the escarpment. Compared with the control sites, the prevalence of AAT was very low. *Trypanosoma vivax* was the only species found. Contrary to expectations, the risks of mechanical transmission seemed to be rather remote within the pastoral zone. Potential mechanical vectors, such as *Tabanids*, *Stomoxys* flies and *Hippoboscids*, were permanently caught, but obviously failed to transmit *T. vivax* in important numbers. A high infection rate with *T. theileri* — examination III revealed 17.9% out of 291 labelled bovines — was further indirect proof of the presence of potential mechanical vectors.

In contrast to the findings of Bambara [6] and the statement of Pinder et al. [7], *T. vivax* was the main pathogen. Bambara examined a total of 417 bovines of different ages and unknown origin. The animals arrived at the local abattoir in Bobo-Dioulasso and were examined only once at the end of 1983. Seventeen per cent of the animals showed trypanosomiasis, out of which 83% were *T. congolense*, 14% were *T. vivax* and 3% were mixed infections.

Reliable data on the prevalence of AAT and its relative importance should be available before a tsetse fly campaign. Generally, there is a lack of information, which seriously hampers the cost-benefit analysis of a tsetse fly campaign. Therefore, we strongly recommend starting with epidemiological/entomological surveys prior to the implementation of a tsetse fly control or eradication campaign. Ideally, this survey would accompany, and even run longer than, a tsetse fly campaign, thus

allowing close monitoring of the efficacy of the control measures. This could also be very helpful in the mobilization of the local population such that the efficacy and the benefits of the control measures will be better understood. The ultimate objective is active participation and support by the local population of tsetse fly control/eradication campaigns, leading to the take-over locally of essential work by the end of a project. For instance, the running costs for the maintenance of the barriers in the pastoral zone of Sidéradougou amount to approximately CFAF 9 million/year.¹ These costs could be substantially reduced if the local population were involved.

There are a number of effective tools available to combat the tsetse fly. The use of traps and insecticide impregnated screens, followed by releases of sterile males, has proved to be very effective in Burkina Faso and Nigeria. The option of whether to achieve control or eradication has been discussed in detail by other authors. According to our experience, it is important to implement tsetse fly campaigns in areas where there is an interest to improve livestock production and where a legal framework exists beforehand. With respect to the West African region, the importance of land use studies and land use planning before the implementation of a tsetse fly campaign cannot be overemphasized as there is a steadily increasing demand for land. Long term planning is required to identify and define potential areas for pastoral/agropastoral or agricultural use.

REFERENCES

- [1] BAUER, B., FILLEDIER, J., KABORE, I., Large-scale rearing of tsetse flies (Diptera, Glossinidae) in the C.R.T.A., Bobo-Dioulasso, Burkina Faso, based on *in vitro* feeding techniques, *Rev. méd. vét. pays trop.* **37** (1984) 9.
- [2] POLITZAR, H., CUISANCE, D., An integrated campaign against riverine tsetse, *Glossina palpalis gambiensis* and *Glossina tachinoides*, by trapping and the release of sterile males, *Insect. Sci. Appl.* **5** (1984) 439.
- [3] WOO, P.T.K., Evaluation of the haematocrit centrifuge and other techniques for the field diagnosis of human trypanosomiasis and filariasis, *Acta Trop.* **28** (1971) 298.
- [4] WALKER, P.J., Capillary concentration technique applicable to infections of *T. congolense* in cattle, *Trans. R. Soc. Trop. Med. Hyg.* **66** (1972) 348.
- [5] MAYER, J., DENOULET, W., Résultats d'utilisation de boucles d'oreille imprégnées de pyréthroides dans la lutte contre les glossines (Permethrine), *Rev. elev. méd. vét. pays trop.* **37** 3 (1984) 290.
- [6] BAMBARA, X., Mémoire de Fin d'Etudes, CRTA (GTZ/IEMVT) (1984).
- [7] PINDER, M., BAUER, J., FUMOUX, F., ROELANTS, G.E., *Trypanosoma congolense*: Lack of correlation between the resistance of cattle subjected to experimental cyclic infection or to field challenge, *Exp. Parasitol.* **64** (1987) 410.

¹ 1 Communauté financière africaine franc (CFAF) = 2 FF.

**SEASONAL SEX RATIO DISTORTION
IN *Glossina tachinoides* Westwood POPULATIONS
INHABITING PERIDOMESTIC AGRO-ECOSYSTEMS
OF THE NSUKKA AREA, ANAMBRA STATE,
NIGERIA, IN RELATION
TO THE STERILE INSECT TECHNIQUE**

L.C. MADUBUNYI

Department of Veterinary Parasitology and Entomology,
Faculty of Veterinary Medicine,
University of Nigeria,
Nsukka, Nigeria

Abstract

SEASONAL SEX RATIO DISTORTION IN *Glossina tachinoides* Westwood POPULATIONS INHABITING PERIDOMESTIC AGRO-ECOSYSTEMS OF THE NSUKKA AREA, ANAMBRA STATE, NIGERIA, IN RELATION TO THE STERILE INSECT TECHNIQUE.

Glossina tachinoides Westwood populations inhabiting Nsukka peridomestic agro-ecosystems were sampled for sex composition with unbaited blue biconical traps deployed in a cross-section of the biotopes from 06:30 to 18:30 h weekly from April 1983 to March 1987. The sex ratio deviated significantly from 1:1 in favour of males at two locations and in favour of females at a third location. Samples from biotopes where domestic pigs were usually present contained either equal proportions of both sexes or higher proportions of females in contrast to those from biotopes where pigs were scarce or absent, which invariably contained very high proportions of males. There was a marked seasonal difference in the monthly sex ratio, with samples containing higher proportions of females during the wet season (April to October) than in the dry season (November to March). This seasonal variation in sex ratio distortion was significantly correlated with seasonal fluctuations in 'fly apparent density'. These findings are discussed in the light of literature on the sex ratio in tsetse fly populations and their application in the sterile insect technique for tsetse fly control/eradication.

1. INTRODUCTION

Glossina species exhibit a 1:1 sex ratio at emergence [1]. However, owing to the longer life spans of females, the true sex ratio in natural tsetse fly populations is expected to exceed 1:1 in favour of females. Samples of various tsetse fly species usually contain females in the region of 60–70% [2], or 'not far' from 78% [3].

Although the actual value of the sex ratio as a statistical parameter in wild tsetse fly populations has been questioned recently [2], it definitely has practical and bio-economic implications. It is a widely used criterion for evaluating tsetse fly sampling techniques. In this regard, the biconical trap [4] has been found to be more reliable than other methods for sampling the *Glossina palpalis* Robineau-Desvoidy group of

tsetse flies [5]. Also, the successful application of nuclear technology in tsetse fly control/eradication using the sterile insect technique (SIT) requires a comprehensive knowledge of the sex ratio of the target population if the desired 'overflooding' ratio of sterile:wild males is to be achieved. So far, the practice in tsetse fly eradication programmes using SIT is to rear and release irradiated males in numbers aimed at achieving ratios ranging from three to ten sterile males per wild male in the target population following a prerelease reduction of such populations. Reports from SIT campaigns indicate that once an overflooding sterile:wild male ratio has been chosen, and the requisite number of sterile males/time interval computed, eradication operations are geared towards releasing a near constant number of irradiated males at predetermined release sites in the project area until the end of the release phase. This practice assumes that the sex ratio of the target population remains virtually constant in time and space [6].

Glossina tachinoides Westwood is one of the tsetse fly species targeted for control/eradication in Nigeria using SIT. This paper presents findings of an investigation to determine whether the sex composition of *G. tachinoides* populations remains constant in time and space in peridomestic agro-ecosystems.

2. MATERIALS AND METHODS

From April 1983 to March 1987, *G. tachinoides* flies were captured weekly by means of unbaited blue biconical traps [4] in three peridomestic agro-ecosystems near Nsukka: Orië-Orba (6°51'N, 7°27'E), Amesumesu-Edem (6°52'N, 7°20'E) and Ozalla-Edem (6°52'N, 7°19'N). The essential features of these agro-ecosystems have been described by Madubunyi [7]. At points preselected to represent a cross-section (biotopes) of each agro-ecosystem, namely around pigsties, on farmland and refuse dumps frequented by roaming pigs, traps were positioned between 06:00 and 06:30 h and emptied between 18:00 and 18:30 h local time on each sampling day.

All *G. tachinoides* flies caught were separated according to sex and counted. Monthly mean (\pm standard error (SE)) sex composition was evaluated for significant departure from a 1:1 ratio. Differences in monthly sex composition between locations, seasons and trap positions were subjected to statistical tests identified in the results. Separation of the means was by Duncan's Multiple Range Test for unequal replications [8]. The analysis of sex ratio variations in biotopes was confined to Orië-Orba because the population at Ozalla-Edem 'collapsed' [9] and that at Amesumesu-Edem became very small after mid-1985.

3. RESULTS

The *G. tachinoides* populations manifested sex ratios which differed significantly from the 1:1 ratio and levels of abundance, both of which varied with location.

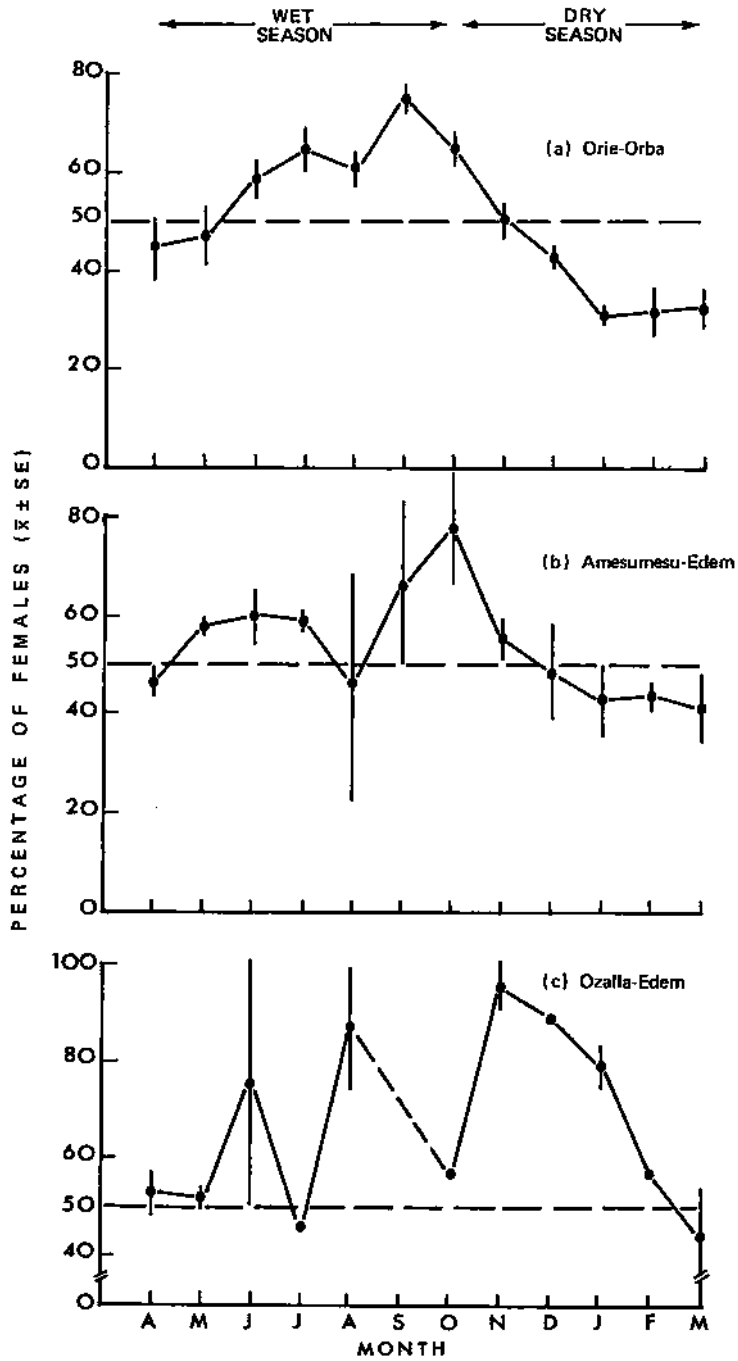

FIG. 1. Monthly fluctuations in the percentage of females in biconical trap samples of peridomestic *G. tachinoides* populations.

TABLE I. SEASONAL PERCENTAGE OF FEMALES IN BICONICAL TRAP SAMPLES OF *G. tachinoides* POPULATIONS IN THE NSUKKA AREA

Location	Monthly mean \pm SE	
	Apparent density	Females (%)
Orie-Orba		
Wet season	15.96 \pm 1.86	59.08 \pm 2.41
Dry season	38.35 \pm 3.20	38.29 \pm 2.46
Amesumesu-Edem		
Wet season	5.67 \pm 0.75	59.43 \pm 4.68
Dry season	7.04 \pm 0.98	46.58 \pm 2.88
Ozalla-Edem		
Wet season	9.46 \pm 2.19	64.93 \pm 6.44
Dry season	2.27 \pm 0.51	72.12 \pm 8.67

Thus, at Orie-Orba the sex ratio (0.79) was significantly distorted in favour of males ($\chi^2 = 159.49$, $P < 0.001$), with 44.10% of the 11 478 flies caught being females. However, at Amesumesu-Edem it (0.97) did not differ significantly from 1:1 ($\chi^2 = 0.28$; $P > 0.05$), as 49.33% of the 1561 flies caught were females. At Ozalla-Edem, on the other hand, the sex ratio (1.17) was significantly distorted in favour of females ($\chi^2 = 7.69$, $P < 0.01$), with 54.01% of the 1198 flies caught being females.

At each location, the proportion of females in the catch varied from month to month (Fig. 1). From April to October (i.e. the wet season), the monthly percentage of females was either equal to, or greater than, that of the males. However, from November to March (i.e. the dry season), there was a steady decrease in the percentage of females in monthly trap samples. These distortions in the sex ratio favouring females during the wet season, also characterized by low 'fly apparent density', and favouring males during the dry season, which is characterized by high fly apparent density (Table I), were highly significant only at Orie-Orba ($P < 0.001$, $t = 5.90$, degrees of freedom (df) = 43) and Amesumesu-Edem ($P < 0.01$, $t = 2.96$, df = 33). At Ozalla-Edem, where females invariably constituted over 64% of the monthly samples, the seasonal difference in sex ratio was not significant ($t = 0.38$, df = 17).

Significant differences ($P < 0.01$) were detected between traps both in monthly fly catches ($F = 27.30$, df = 9/436) and sex composition ($F = 28.74$, df = 9/350) (Table II). Although traps in the same biotope tended to have the same characteristics

TABLE II. PERCENTAGE OF FEMALES IN BICONICAL TRAP CATCHES OF *G. tachinoides* FROM DIFFERENT PARTS OF THE ORIE-ORBA PERIDOMESTIC AGRO-ECOSYSTEM

Trap No.	Biotope	Monthly mean* \pm SE	
		No. of flies	Females (%)
1	Pigsty	23.26 \pm 1.95 ^a	71.49 \pm 2.53 ^a
2		40.19 \pm 3.60 ^b	58.26 \pm 2.75 ^b
3		80.41 \pm 10.69 ^c	58.78 \pm 2.23 ^b
4	Farmland	39.91 \pm 6.31 ^b	18.73 \pm 2.30 ^c
5		30.80 \pm 5.30 ^b	13.40 \pm 1.57 ^c
6	Refuse dump	4.30 \pm 1.20 ^d	47.16 \pm 5.29 ^b
7		4.33 \pm 0.70 ^d	35.79 \pm 4.55 ^b
8		9.13 \pm 1.17 ^{de}	45.89 \pm 4.18 ^b
9		1.62 \pm 0.47 ^d	47.78 \pm 9.26 ^b
10		18.72 \pm 2.03 ^{ec}	49.32 \pm 2.70 ^b

* Means accompanied by the same superscript letter(s) are not significantly different at $P=0.05$.

in the foregoing respects, statistically significant differences were nevertheless observed between traps within the same biotope. Furthermore, individual traps in one biotope were not always statistically separable from those in a different biotope. Generally, however, flies appeared to be most abundant around the pigsty (traps 1-3) and least abundant around refuse dumps frequented by scavenging native pigs (traps 6-10). On the other hand, the percentage of females in monthly catches was highest in the pigsty biotope and lowest in the farmland biotope (traps 4 and 5).

In all biotopes, a high percentage of females in the samples and low apparent density characterized the wet season fly population. The dry season population, on the other hand, was characterized by a low percentage of females in samples and high apparent density (Table III). In the pigsty and farmland biotopes the percentage of females in monthly catches fluctuated during the wet season as fly apparent density decreased steadily. During the dry season, however, the percentage decreased steadily as fly apparent density also increased steadily (Fig. 2). A highly significant correlation was evident between the percentage of females in the catches and the apparent density both around the pigsty ($P < 0.001$, $r = -0.86$, $a = 83.71$, $b =$

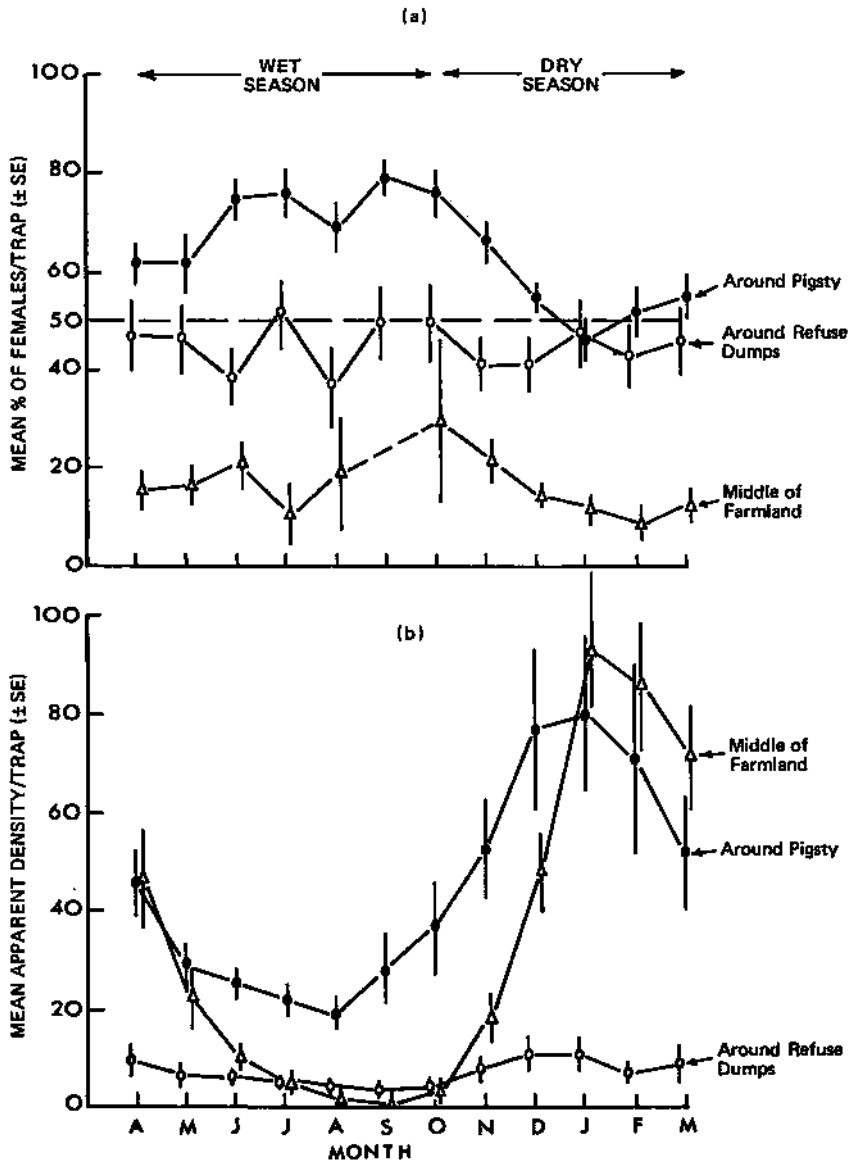

FIG. 2. Monthly fluctuations in the (a) percentage of females and (b) apparent density of *G. tachinoides* in different biotopes of a peridomestic agro-ecosystem.

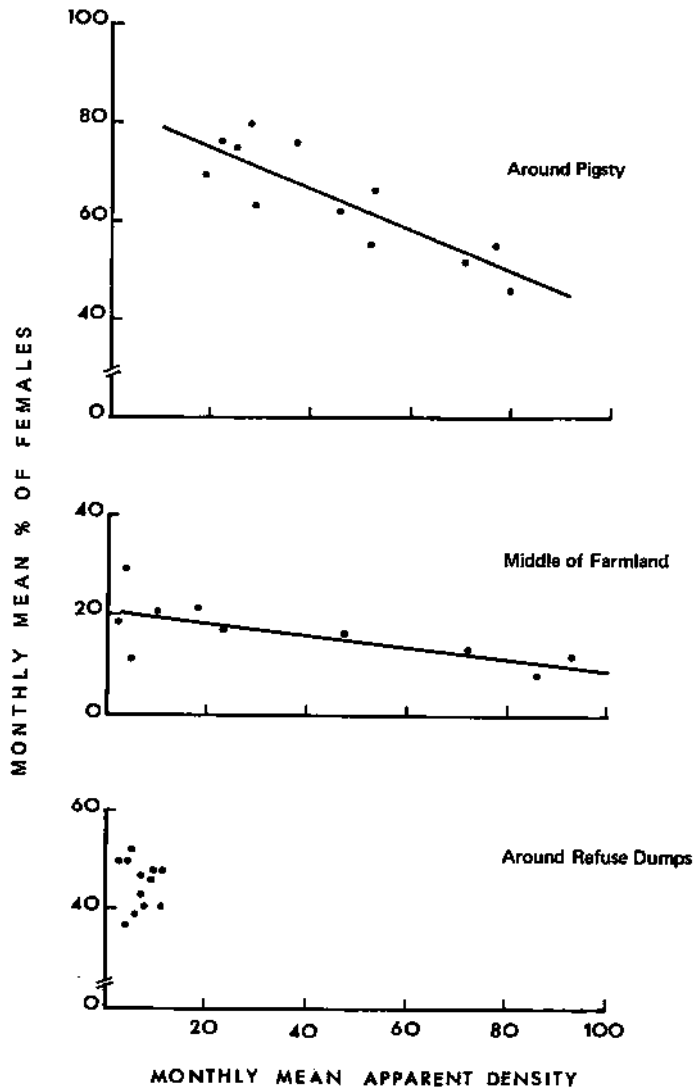

FIG. 3. The relationship between the percentage of females in biconical trap samples and the apparent density of *G. tachinoides* in a peridomestic agro-ecosystem.

TABLE III. SEASONAL APPARENT DENSITY AND PERCENTAGE OF FEMALES IN BICONICAL TRAP CATCHES OF *G. tachinoides* FROM DIFFERENT BIOTOPES OF A PERIDOMESTIC AGRO-ECOSYSTEM

Biotope	Monthly mean \pm SE	
	Apparent density	Females (%)
Pigsty		
Wet season	33.58 \pm 5.13	71.27 \pm 1.97
Dry season	66.65 \pm 6.62	54.77 \pm 2.09
Farmland		
Wet season	13.67 \pm 2.88	18.11 \pm 2.53
Dry season	63.55 \pm 6.41	14.06 \pm 1.38
Refuse dump		
Wet season	5.92 \pm 0.68	45.92 \pm 2.87
Dry season	9.32 \pm 1.25	44.41 \pm 3.00

-0.43, $df = 10$) and in the middle of farmland ($P < 0.05$, $r = -0.66$, $a = 21.12$, $b = -0.12$, $df = 9$) (Fig. 3). Similar seasonal differences in the monthly sex ratio and a significant correlation between apparent density and sex ratio were not evident in trap catches from around refuse dumps, where the tsetse fly apparent density remained evenly low throughout the year.

4. DISCUSSION

Baldry reported that in the Nsukka area, females usually constitute about 68% in hand-net catches of *G. tachinoides* [10]. He later added that although flies of both sexes may occur in equal proportions during the early wet season, for most of the year females are more available than males and may constitute 80% of the fly catches at the height of the wet season [11]. The results of the present study corroborated the foregoing only during the wet season and only in certain biotopes of the peridomestic agro-ecosystems, namely around the pigsty (female composition 60-80%) and refuse dumps (equal proportions of both sexes).

Simpson's observations on the sex ratio of *G. tachinoides* at Yapi, Ghana (then the Gold Coast), produced probably the first indication that this population parameter could vary within the same month in the same location [12]. Since then, several authors have mentioned fluctuations in the sex ratios of various tsetse fly species

throughout the year [2]. With regard to *G. tachinoides*, Gruvel reported a practically constant low sex ratio (i.e. distorted in favour of males) during the dry season in the Republic of Chad [13]. The results of the present study show that not only does the sex ratio of *G. tachinoides* remain constantly low throughout the dry season at Nsukka, Nigeria, it is also usually low throughout the year in certain biotopes of peridomestic agro-ecosystems, especially in the middle of farmland. The results further show that it differs substantially between biotopes and fluctuates monthly in each biotope.

In the Numan Division of Adamawa Province (now Saradauna) of northern Nigeria, Davies observed that where the *G. tachinoides* density was comparatively low (less than 10 flies/'boy-hour'), only 30% of the flies caught were females, but where the density was higher (more than 20 flies/'boy-hour'), 50% were females [14]. On the Duddurun Gaya River, also in northern Nigeria, Davies noted that larger percentages of female flies were caught immediately after insecticidal spraying (i.e. low fly density) than before the spraying (i.e. high fly density) [15]. Clearly, the foregoing suggest that the sex ratio in *G. tachinoides* is related to fly population density in a manner which could differ dramatically between fly populations (and locations). This was strongly supported by data from the present study and offers an explanation for the sex ratio differences detected between locations and seasons. Evidently, in the Nsukka area, low percentages of females in samples of *G. tachinoides* are associated with high fly density in time and space. Within locations, however, the sex ratio differed between biotopes in a manner which appeared unrelated to fly density only. Nevertheless, in each biotope seasonal sex ratio fluctuations were strongly associated with seasonal fluctuations in fly apparent density.

Differences between biotopes with regard to the sex ratio of the *G. palpalis* group of tsetse flies have been ascribed to a selective use by the sexes of different parts of the ecosystem according to the main phases of their existence: mating, breeding, feeding, resting and dispersal [13, 16-19]. Thus, in the preforest zone of the Côte d'Ivoire, a high proportion of the females in biconical trap catches of *G. palpalis* in villages and open areas was associated with feeding grounds. On the other hand, a high proportion of males in catches from adjoining plantations and fringing forests was associated with resting and breeding sites. In peridomestic agro-ecosystems of the Nsukka area, *G. tachinoides* breeds at an evenly high rate year round [20] and rests and larviposits in sites scattered throughout the surrounding farmland and around pig enclosures [21]. Consequently, functional partitioning of this ecosystem by this fly with regard to breeding and resting sites is doubtful and is further called into question by the fact that not only are females rarely caught in farmland, but that it is also very difficult to find puparia in this biotope, particularly during the wet season, when fly density is also usually at its lowest [7] in all parts of the agro-ecosystem. Nevertheless, irrespective of fly density or season, higher proportions of females in catches were recorded in biotopes where domestic pigs, the preferred hosts of *G. tachinoides* [10], were usually present, namely the pigsty and refuse dumps fre-

quented by pigs. Therefore, high percentages of males in samples of *G. tachinoides* may not be more than an indication of the relative scarcity of preferred hosts in the various biotopes of the ecosystem.

A sex ratio distortion in favour of males has been reported in many tsetse fly species throughout tropical Africa from the earliest days of tsetse fly research [22]. However, these observations were usually dismissed rather lightly on some classical behavioural premises, e.g. that males are generally on the prowl, whether hungry or not, and so are more readily captured than females [23]; that females are usually fugitive, except when hungry, and with good reason seek to avoid males on account of the latter's extreme violence in mating, which may result in injury to the females or their young [24]; inadequacies of sampling techniques; insufficient coverage of biotopes, etc. Nevertheless, in recent times, sex ratio distortion in favour of males has been induced in *G. morsitans* Westwood by irradiation [25] and in *G. pallidipes* Austen by mating females with normal salivary glands with males infected with a DNA virus which causes salivary gland hyperplasia and gonadal pathologies and which shortens the life-span of both sexes [26].

In addition, sex ratio distortion in *G. m. submorsitans* Newstead has been traced to 'distorter' males [27] and has been shown to be genetically controlled [28]. Therefore, naturally occurring sex ratio distortion in favour of males, such as that detected in the present study, deserves more serious consideration than hitherto given. While the data at hand cannot deal with the question of the causes of the observed seasonal changes in the distortion, a clear understanding of the underlying mechanisms could find ready application in modern tsetse fly population management. It is pertinent to recall that higher puparial weight (and thus, by implication, better maternal nourishment) has been linked with lower percentages of males in *G. p. palpalis* (Robineau-Desvoidy) [29].

The results of this study show that significant deviations from a 1:1 sex ratio in natural tsetse fly populations are neither always in favour of females nor always explainable by the longer life-spans of the females. They further show that the sex ratios in populations of *G. tachinoides* do not remain constant in time and space and the variations may not be as negligible as is often assumed in mathematical models of the sterile male principle. The results suggest that a high percentage of males in samples of the tsetse fly may be indicative of the relative scarcity of preferred hosts in parts of the ecosystem. Significant seasonal deviations from a 1:1 sex ratio in favour of males would periodically upset the ratio of sterile to wild males in SIT programmes and could lead to delay/failure in achieving eradication, without necessarily involving immigrant wild flies. Also, because male apparent density could differ dramatically between biotopes of the same ecosystem, correspondingly different numbers of irradiated males have to be released in parts of the project area to achieve and maintain the desired overflooding ratio of sterile to wild males evenly and at all times. It is thus obvious that more attention needs to be given to the seasonal sex ratio dynamics of target tsetse fly populations during prerelease activities in SIT programmes.

ACKNOWLEDGEMENTS

This work was financed through grants by the International Atomic Energy Agency, Vienna, and the University of Nigeria, Nsukka. The assistance of Johnson Nwosu is greatly appreciated.

REFERENCES

- [1] BUXTON, P.A., The natural history of tsetse flies. An account of the biology of the genus *Glossina* (Diptera), Mem. Lond. Sch. Hyg. Trop. Med. No. 10 (1955).
- [2] CHALLIER, A., The ecology of tsetse (*Glossina* spp.) (Diptera:Glossinidae): A review (1970-1981), Insect Sci. Appl. 3 (1982) 97-143.
- [3] GLASGOW, J.P., "The *Glossina* community", The African Trypanosomiasis (MULLIGAN, H.W., Ed.), George Allen and Unwin, London (1970) 395-415.
- [4] CHALLIER, A., EYRAUD, M., LAFAYE, A., LAVEISSIÈRE, C., Amélioration du rendement du piège biconique pour glossines (Diptera, Glossinidae) par l'emploi d'un cône inférieur bleu, Cah. ORSTOM Sér. Entomol. Méd. Parasitol. 15 (1977) 283-286.
- [5] GOUTEUX, J.-P., DAGNOGO, M., Écologie des glossines en secteur pré-forestier de Côte d'Ivoire. II. Comparaison des captures au piège biconique et au filet, Aggressivité pour l'homme, Cah. ORSTOM Sér. Entomol. Méd. Parasitol. 24 (1986) 99-100.
- [6] BERRYMAN, A.A., Mathematical description of the sterile male principle, Can. Entomol. 99 (1971) 858-865.
- [7] MADUBUNYI, L.C., Aspects of the ecology and epizootiological/epidemiological importance of *Glossina* species inhabiting a peridomestic agroecosystem in the Nsukka area, Anambra State, Nigeria, Insect Sci. Appl. 7 (1986) 515-520.
- [8] STEEL, R.G.D., TORRIE, J.H., Principles and Procedures of Statistics with Special Reference to the Biological Sciences, McGraw-Hill, New York (1980).
- [9] MADUBUNYI, L.C., The collapse of *Glossina tachinoides* (Diptera:Glossinidae) populations in two peridomestic agroecosystems in the Nsukka area of Anambra State, Nigeria, Insect Sci. Appl. (in press).
- [10] BALDRY, D.A.T., Observations on a close association between *Glossina tachinoides* and domestic pigs near Nsukka, Eastern Nigeria. II. Ecology and trypanosome infection rates in *G. tachinoides*, Ann. Trop. Med. Parasitol. 58 (1964) 32-44.
- [11] BALDRY, D.A.T., The epidemiological significance of recent observations in Nigeria on the ecology of *Glossina tachinoides* Westwood (Diptera:Muscidae), Bull. Entomol. Soc. Nigeria 2 (1969) 34-38.
- [12] SIMPSON, J.J., Bionomics of tsetse and other parasitological notes in the Gold Coast, Bull. Entomol. Res. 8 (1918) 193-214.
- [13] GRUVEL, J., Structure des populations de *Glossina tachinoides* Westw. à la réserve de Kalamaloué. VI, Revue Élev. Méd. Vét. Pays Trop. 28 (1975) 195-215.
- [14] DAVIES, M., *Glossina* distribution in the Numan Division, Adamawa Province, Department Rep., Veterinary and Tsetse and Trypanosomiasis Unit Files (1955).
- [15] DAVIES, J.B., Report on insecticidal spraying operations on the Duddurun Gaya River, Department Rep., Medical and Sleeping Sickness Service Files (1958).
- [16] CHALLIER, A., GOUTEUX, J.-P., Ecology and epidemiological importance of *Glossina palpalis* in the Ivory Coast forest zone, Insect Sci. Appl. 1 (1980) 77-83.

- [17] GOUTEUX, J.-P., LAVEISSIÈRE, C., Écologie des glossines en secteur pré-forestier de Côte d'Ivoire. 4. Dynamique de l'écodistribution en terroir villageois, Cah. ORSTOM Sér. Entomol. Méd. Parasitol. **20** (1982) 199-229.
- [18] RANDOLPH, S.E., ROGERS, D., Local variation in the population dynamics of *Glossina palpalis palpalis* (Robineau-Desvoidy) (Diptera:Glossinidae). II. The effect of insecticidal spray programmes, Bull. Entomol. Res. **74** (1984) 425-438.
- [19] GOUTEUX, J.-P., Écodistribution de *Glossina palpalis palpalis* (Rob.-Desv.) en secteur préforestier de Côte d'Ivoire. Sexe, rythmes ovaro-utérins et utilisation de l'espace, Acta Oecol. — Oecol. Appl. **8** (1987) 27-38.
- [20] MADUBUNYI, L.C., The seasonal breeding rate of *Glossina tachinoides* Westwood (Diptera:Glossinidae) in peridomestic agroecosystems of the Nsukka area, Anambra State, Nigeria, Bull. Entomol. Res. **78** (1988) (in press).
- [21] BALDRY, D.A.T., Observations on the peridomestic breeding behaviour and resting sites of *Glossina tachinoides* Westw. near Nsukka, East Central State, Nigeria, Bull. Entomol. Res. **59** (1968) 585-593.
- [22] SQUIRE, F.A., On the sex ratio in *Glossina*, Bull. Entomol. Res. **43** (1953) 231-235.
- [23] FISKE, W.F., Investigations into the bionomics of *Glossina palpalis*, Bull. Entomol. Res. **10** (1920) 347-463.
- [24] LAMBORN, W.A., Second report on *Glossina* investigations in Nyasaland, Bull. Entomol. Res. **6** (1915) 249-265.
- [25] CURTIS, C.F., et al., Sex ratio distortion and semi-sterility in the progeny of irradiated *Glossina morsitans*, Genet. Res. **21** (1973) 153-165.
- [26] JAENSON, T.G.T., Sex ratio distortion and reduced life-span of *Glossina pallidipes* infected with the virus causing salivary gland hyperplasia, Entomol. Exp. Appl. **41** (1986) 265-271.
- [27] RAWLINGS, P., MAUDLIN, I., Sex ratio distortion in *Glossina morsitans submorsitans* Newstead (Diptera:Glossinidae), Bull. Entomol. Res. **74** (1984) 311-315.
- [28] GOODING, R.H., Evidence for genetic control of sex ratio distortion in two colonies of *Glossina morsitans submorsitans* Newstead (Diptera:Glossinidae), Quaest. Entomol. **22** (1986) 19-28.
- [29] TENABE, S.O., GREILING, J., "Studies on the performance of flies emerging from groups of laboratory bred puparia of *Glossina palpalis palpalis* in different weight classes", Proc. 17th Mtg Int. Scientific Council for Trypanosomiasis Research and Control Arusha, Tanzania, 1981, Organization for African Unity/STRC Pub. No. 112, Nairobi (1983) 508-512.

GENETICS AS A COMPONENT OF VECTOR MOSQUITO CONTROL IN EAST AFRICA

T.K. MUKIAMA
Department of Botany,
University of Nairobi,
Nairobi, Kenya

Abstract

GENETICS AS A COMPONENT OF VECTOR MOSQUITO CONTROL IN EAST AFRICA.

Among the proposed genetic control methods that have been tested with a degree of success are the release of sterile males, cytoplasmically incompatible strains and strains carrying chromosomal aberrations. In East Africa, the most important mosquitoes are *Anopheles gambiae sensu strictu*, which transmits malaria, filariasis and the O'nyong-nyong virus; *An. arabiensis*, which transmits malaria, filariasis and the Tatguine virus; and *An. funestus*, which transmits malaria, filariasis and the O'nyong-nyong and Tanga viruses. Other important vectors are *Aedes simpsoni*, which transmits yellow fever, and *Ae. africanus*, which is responsible for the forest cycle of the disease among monkeys. Cytological examination of specimens of *An. gambiae sensu lato* resulted in 804 positive identifications of the XB type chromosome only, indicating that *An. arabiensis* is the most abundant, and probably the only, member of the complex present, and constitutes close to 65.7% of the total mosquito population. Blood meal analysis of 1024 specimens showed its marked preference for bovid (51.9%) and human (28.1%) blood. Sporozoite rating by dissection and enzyme linked immunosorbent assay averaged 0.02%. Control methods tried in the past include chemical spraying and environmental management in the Kisumu area. A trial against *An. arabiensis* is suggested at Karima village, in Mwea, whereby an integrated approach incorporating environmental, chemical and genetic measures could be undertaken. This would take advantage of the low population during the dry season from mid-December to mid-April and would involve biological larviciding, mass pyrethrum spraying and the release of sterile males. There is a lack of adequate genetic knowledge of this species, especially genetic markers and linkage relationships, even though chromosome maps are available and inversion polymorphism is better understood. Notice should be taken of the reportedly discouraging results of genetic control trials, where failure has been attributed to immigration, poor competitiveness of laboratory produced males, failure to mate or density dependent mortality.

1. INTRODUCTION

Several methods applicable to the genetic control of mosquitoes have been proposed, and detailed reviews of their theoretical bases and practical feasibility have been made [1-3]. These methods include the release of sterile males [3-6]; the use of strains exhibiting cytoplasmic incompatibility [7] (a characteristic since shown to be produced by symbionts rather than genetic factors [8]); the use of strains carrying chromosomal aberrations [3,9,10]; the induction of both recessive and dominant lethal mutations [2];

the use of strains with sex distorting genes and meiotic drive factors [2]; and the release of sterile hybrids [11]. In addition, population replacement has been proposed using heterozygote inferiority or underdominance with respect to incompatibility systems [3]. The replacing strain should have other desirable characteristics, such as refractoriness to disease agents or resistance to insecticides [7]. The possibility of utilizing autogenous strains of mosquitoes for population replacement has also been proposed [12,13], whereby a non-biting autogenous mutant could be produced as the replacing strain, with the introduction of and selection for other desirable qualities being a necessary prerequisite.

In the light of these possible methods, this paper looks at the vector mosquito situation in East Africa and, with special reference to Anopheles arabiensis, explores the possibility of incorporating genetics in a control strategy in terms of locality, time and the prevailing socio-economic conditions.

2. VECTOR MOSQUITOES OF EAST AFRICA

Numerous species of mosquitoes abound in East Africa, and a detailed account of their taxonomy and bionomics is given by Gillies and de Meillon [14]. All lowland wetlands of East Africa are prone to colonization by mosquitoes but, owing to the patterns of human habitation, only certain areas are of special concern. These include the humid coastal strip of the Indian Ocean, inland areas along the shores of most freshwater lakes and inland water reservoirs either for hydro-electric power generation or irrigated farming.

General accounts of the mosquito fauna of the Lake Victoria region are given in the literature [14,15]. Recent studies in the area, however, have paid particular attention to the vectors of malaria, the An. gambiae complex [16-22] and the impact on the mosquito fauna of major ecological changes associated with extensive rice irrigation farming [23-30]. In this area, An. gambiae sensu strictu (s.s.) is a vector of malaria [18,21] as well as the O'nyong-nyong and Bwamba viruses [22] and filariasis [22]. An. arabiensis is a vector of malaria, filariasis and the Tatguine virus. An. merus exhibits significantly lower sporozoite rates in nature, even though laboratory strains develop parasite infectivity rates of the same order as An. gambiae s.s. or An. arabiensis. It is a much less important vector of malaria, but transmits filariasis. Other members of the complex, An. quadriannulatus and species D, are less well known, although the latter is suspected to be the main vector of malaria and filariasis where it occurs in the Semliki area of Western Uganda [22]. The other

important vector is An. funestus, which transmits malaria, filariasis, O'nyong-nyong virus and Tanga virus [14]. An. pharoensis is a common mosquito in East Africa, but is not known to transmit malaria, even though its importance as a vector is well proven in Egypt, Sudan and Zaire [31].

Important culicine vectors include Aedes simpsoni, which transmits yellow fever [32-34], and Ae. africanus, which is responsible for the forest cycle of yellow fever among monkeys, but also serves as the link between this cycle and the human one involving Ae. simpsoni [35]. Other common biting mosquitoes are Ae. aegypti [36-43], Culex quinquefasciatus (Mukiama and Mwangi, unpublished) and several Mansonia species [25, 29].

3. MWEA RICE IRRIGATION SCHEME

In recognition of the difficulties expected in attempting to discuss the possibility of using a genetic component in the control of mosquitoes in an area as large and diverse as East Africa, it is considered more realistic to specifically refer to the situation in an area of recent study. This is the Mwea Rice Irrigation Scheme in Central Kenya. Research interest in this area started in 1982, and studies in different aspects of mosquito biology are still in progress.

3.1. The study area

The Mwea Irrigation Scheme was developed about 25 years ago in a riverine flood plain 50 km south-east of Mt. Kenya. It uses the waters of the Thiba River, a tributary of Kenya's longest river, the Tana. Its geographical position is roughly between 37°15' to 37°30' east and 0°30' and 0°45' south. This area is about 120 km by road from Nairobi. The irrigated zone measures about 150 km² and is criss-crossed by a network of canals and dirt access roads. The altitude is between 1200 and 1300 metres above sea level. The general topography is that of a basin, surrounded by hilly, high ground in all directions except the south-east. The soil is predominantly of the black cotton type. About 30 villages are scattered within the Scheme, where the peasant farmers are housed in very high concentrations, together with most of their livestock. The meteorological data (1984-1986) are given in Table I.

Karima village in Mwea lies about 1.5 km from the nearest neighbouring village and is completely surrounded by rice fields. The village is a concentration of about 50 mud and corrugated iron houses, with an average of about 7 people per house. The village is about 200 metres at its longest and about 60 metres at its widest point. Chickens, goats and sheep stay

TABLE I. METEOROLOGICAL DATA FOR MWEA IRRIGATION SCHEME, 1984-1986

MONTH/YEAR	MEAN RELATIVE HUMIDITY (%)	TOTAL RAINFALL (mm)	TEMPERATURE (°C)		RICE FIELD CONDITION
			MEAN MAX.	MEAN MIN.	
JAN 1984	48.5	5.8	29.9	14.4	NF
FEB	54.4	0*	31.6	14.3	NF
MAR	45.8	11.4	31.8	17.3	NF
APR	56.8	144.1	30.9	18.9	PF
MAY	53.5	8.9	29.1	18.2	F
JUN	56.6	3.9	-	16.2	F
JUL	61.5	4.6	-	16.5	F
AUG	61.0	3.7	-	16.4	F
SEP	51.0	19.8	-	16.7	F
OCT	61.9	219.6	-	17.7	F
NOV	68.6	147.5	-	16.9	F
DEC	62.4	42.3	26.4	15.5	PF
JAN 1985	52.7	10.6	29.4	14.5	NF
FEB	48.9	68.5	30.2	17.2	NF
MAR	53.6	69.0	31.0	16.9	NF
APR	66.1	475.5*	27.2	16.6	PF
MAY	67.5	54.3	26.1	17.5	F
JUN	66.8	0.9	24.9	15.9	F
JUL	62.0	2.4	24.7	15.8	F
AUG	56.0	6.0	24.9	15.7	F
SEP	51.9	1.5	29.0	17.0	F
OCT	53.8	47.2	29.2	17.0	F
NOV	67.8	136.4	27.4	17.3	F
DEC	60.5	33.2	28.0	14.9	PF
JAN 1986	43.6	3.2	30.9	14.0	NF
FEB	37.7*	0*	32.8*	14.9	NF
MAR	52.2	90.3	30.9	16.7	NF
APR	61.1	291.8	28.4	17.6	PF
MAY	68.5	105.8	26.7	17.1	F
JUN	68.9*	15.5	23.7	15.6	F
JUL	61.4	0*	24.4	14.5	F
AUG	55.2	5.8	26.7	14.1	F
SEP	49.3	17.6	28.1	15.6	F
OCT	51.6	52.0	30.0	16.9	F
NOV	68.1	224.1	26.9	16.8	F
DEC	65.7	151.1	26.5	15.7	PF
Mean	57.6	68.7	28.3	16.2	

Note: F - Flooded.
 PF - Partially flooded.
 NF - Not flooded.
 * - Range.

indoors overnight, while cattle and donkeys stay in enclosures adjoining the dwellings. Large numbers of mosquitoes were always recorded in the village.

3.2. The rice cycle

The rice cycle begins in August when the fields are completely flooded and rice seedlings are transplanted from nursery plots. The growth period continues up to late November, when the crop ripens and is eventually harvested in early December. The growing period coincides with the short rainy season, which occurs in October and November. During this time, the irrigation water is diverted to the main channels, such that by the time the rice reaches maturity, the fields are actually dry.

Extremely dry weather follows in late December, January, February, March and up to mid-April, when the long rains begin. During this period, the rice fields lie fallow, with livestock grazing in them. Natural flooding occurs during the long rainy season, whose termination is rather unpredictable, but is on average some time in June. Weeding and general preparation of the fields takes place during this period until reflooding and planting in August.

3.3. The mosquitoes of Mwea

In 1984 and 1985, a survey was made in Mwea to determine the mosquito species present and their seasonal dynamics. The sampling techniques used were pyrethrum space spraying for the daytime indoor resting population and Center for Disease Control (CDC) miniature light traps for the night-time house entering population. Of the total of 23 397 mosquitoes identified, the most abundant species (comprising 99% of the total) were An. gambiae sensu lato (s.l.) (65.71%); C. quinquefasciatus (21.00%) and An. pharoensis (12.29%). The other species, in the order of their abundance, were C. tigripes, An. funestus, C. nebulosus, C. univittatus, An. pretoriensis, An. maculipalpis, An. coustani, Ae. quasiunivittatus and M. fuscopennata.

Blood meal analysis of fed An. gambiae s.l. mosquitoes (1024 specimens) showed that 51.9% fed on bovids, 28.1% on man, 3.9% on avians, 2.1% on canids and 2.1% on equids. Salivary gland dissections of adult females showed a sporozoite rating of 0.03%, while analysis by enzyme linked immunosorbent assay (ELISA) gave 0.01%.

3.4. The genetics of An. arabiensis

Speciation in the An. gambiae complex is based on intraspecific chromosome differentiation. Specifically, the

TABLE II. MEAN FREQUENCIES OF THE MOST COMMON ALLELES (WITH A FREQUENCY GREATER THAN 0.10) IN An. arabiensis OF MWEA IRRIGATION SCHEME, KENYA

ALLELE	S	I	F	OTHERS
<u>LOCUS</u>				
<u>Ac</u>	0.91	-	-	0.09
<u>Idh</u>	0.76	-	0.23	0.01
<u>6-Pgd</u>	0.73	-	0.19	0.08
<u>Odh</u>	0.89	-	0.10	0.01
<u>Pgm-1</u>	-	0.96	-	0.04
<u>Adh</u>	0.16	0.50	0.34	-
<u>Est-1</u>	0.43	0.13	0.44	-
<u>beta-Had</u>	0.17	-	0.81	0.02

presence of fixed inversions on the X and 2nd chromosomes forms the basis for the identification of the members of this group [44]. Further possibilities of identification result from electrophoretic variation in a few gene-enzyme systems [45, 46].

A total of 804 specimens of An. gambiae s.l. from villages in Mwea were positively identified as An. arabiensis by the XB chromosome type. No positive identifications of the rest of the members of the group were made. The identified specimens included both outdoor and indoor resting catches. This suggests that An. arabiensis is the most abundant, and probably the only, member of the species complex present in Mwea.

The formal genetics of anophelines have been reviewed by Kitzmiller and Mason [47], Kitzmiller [48] and Narang and Seawright [49]. In Mwea, the morphological larval mutants black diamond, collarless and stripe were regularly observed in the field, but no adult mutants were observed.

Although a considerable number of enzyme variants have been described in An. arabiensis, none have been assigned to specific chromosomes or linkage groups [49], although Pgm, Est-1, Est-2 and Est-3 are known to be under autosomal control. Loci assigned to specific chromosomes include white eye in chromosome I, diamond, DDT-resistance and dieldrin resistance genes in chromosome II and collarless in chromosome III [49]. Recent studies by Lines et al. [50] indicate that malathion resistance is incompletely dominant, is probably under the control of one gene and is likely to be under the influence of a sex linked modifier.

Electrophoretic variation was screened in eight enzymes in cytologically identified specimens of An. arabiensis from Mwea [51]. Seven loci had polymorphic alleles, of which at least two

were common (Table II). Pooled allele frequencies at the Pgm, beta-Had and Odh loci were in Hardy-Weinberg equilibrium, while those at the Ao, Idh, Est-1 and 6-Pgd loci showed significant deviations. The frequency of heterozygotes at the Adh, Est-1 and 6-Pgd loci was less than expected, while at the Ao locus, there was an excess. The respective gene frequencies and the villages were statistically shown to be in association, suggesting that each village actually constitutes a distinct population, with alleles at the various loci most likely in Hardy-Weinberg equilibrium. It can therefore be expected that little gene flow occurs between these isolated village populations.

3.5. Previous control trials in Kenya

Studies conducted in the Ahero Rice Irrigation Scheme in Kisumu District, Western Kenya, have shown that rice fields provide a stable habitat for mosquito breeding, and that a combination of environmental control methods, backed by sound planning and design, could greatly reduce the numbers of man biting mosquitoes [23-30], and hence the degree of disease transmission. Grainger [23] found larvae of An. gambiae and An. funestus in this area and attempted, without success, to control them by intermittent irrigation and desiccation. Chandler and Highton [28] have recommended similar techniques coupled with rice crop husbandry practices that take account of the height, spacing, transplanting period and water depth as environmental management measures that are likely to prove effective in the long run. Surtees [24] experimentally showed that anopheline larvae tended to accumulate close to the surface in centres of minimal water movement, suggesting that in practice they could be flushed out of rice fields by increasing the current in the flow of irrigating water. A comprehensive review of possible environmental and chemical methods of control is given by the same author [27].

Insecticidal spraying against adults was undertaken in the Kisumu area in the early 1970s using fenitrothion [19, 20]. The results showed an increase in the degree of exophily in An. arabiensis and its numbers relative to An. gambiae s.s., but with a great reduction in the numbers of both species. It was also suggested that the movement away from houses increased the preference of An. arabiensis for cattle.

No organized control activities have been reported against mosquitoes in Mwea.

In the 1970s, the only local genetic control trial was launched in the village of Rabai, near Mombasa, in the Coast Province, against Ae. aegypti [40, 41]. Double translocation heterozygote males were obtained by crossing two different translocation homozygotes, one involving chromosomes 1 and 3,

and the other chromosomes 1 and 2. Prerelease sexing was done in the pupal stage for eliminating the females. About 500 males were released daily over 61 days. The population was monitored by landing-biting catches twice weekly, indoor oviposition traps once weekly and collection of pupae once weekly. The target village population was about 1200 mosquitoes as determined by mark-release-recapture. Release males were shown to be equally competitive with wild males under laboratory conditions. Partial sterility was introduced into the release village population and a considerable reduction in numbers was achieved as evidenced by the severe decline of oviposition rates a few weeks following termination of the release programme. In both the release and control villages, increases in oviposition rates were observed which were not associated with comparable increases in pupal productivity. The relatively steady output of pupae during periods of varying egg production was deemed to be due to density dependent larval mortality, whereby the sterility induced by the translocations resulted in fewer larvae hatching, and consequently increased the probability of survival of those larvae that did hatch. It was also observed that seasonal factors contributed to the mosquito population fluctuations, thus further complicating the assessment of the actual effects of the translocation induced sterility.

4. A PROPOSED CONTROL STRATEGY AT KARIMA VILLAGE, MWEA

4.1. Prerequisites

The following considerations are indispensable if a control trial involving genetic components is to be implemented:

- (1) Since the most realistic and practical genetic mechanism to utilize is the sterile male, it is imperative that the proper genetic strains be produced and isolated. From past experience, such strains could carry chromosome aberrations, which should be appropriately labelled by morphological genetic markers.
- (2) The identified special laboratory strains should then be colonized under laboratory conditions and selected for preferable physiological and behavioural characteristics.
- (3) Mass rearing techniques should then be perfected for the selected future field-release stock and should incorporate quality control measures.
- (4) A genetic sexing mechanism should be introduced into the special strain in the mass rearing facility so that females are eliminated, preferably at the egg stage. Sterilization of males should then be effected.

- (5) Delivery and release methods should be streamlined.
- (6) Monitoring and programme evaluation techniques should be identified and pre-tested.
- (7) Estimates of costs, personnel, time and the actual location of the production facilities should be carefully considered.
- (8) A pilot study should be carried out to determine the seasonal fluctuations in mosquito numbers, the species composition (especially the An. gambiae complex), and to estimate the total number of mosquitoes in the release village.

4.2. Control strategy

The control strategy should essentially be an integrated one, including the following:

- (1) August-November: Field operations during this period should ensure that all major and subsidiary irrigation canals are cleared and cleaned up to ensure uninterrupted water flow; all fields are weeded; strong banks are maintained alongside the plots and canals to prevent seepage of water or overflow; by the end of November all fields should be completely drained and water directed into the main channels. The ensuing clear, hot and sunny conditions should enable the fields to dry up.
- (2) If any areas still contain stagnant water which cannot be drained off or is too deep to dry up naturally, biological larviciding should be introduced by utilizing spore-forming bacteria (Bacillus thuringiensis, B. sphaericus) or larvivorous fish, depending on the size and nature of the water bodies. This should be sustained throughout the trial period. The possibility also exists of larviciding with dilute formulations of Melia yokensii extracts, which have been shown to be very effective against mosquito larvae [52].
- (3) From December to the end of January, an intensive pyrethrum spraying activity should be initiated and sustained. This, together with the prevailing dry weather conditions, should drastically suppress the native vector population.
- (4) From February, sterile male An. arabiensis, incorporating appropriate genetic mechanisms, should be released and continued daily for the next 4 months.
- (5) From June, post-release monitoring should begin and continue up to the next dry season. This should essentially involve the identification of surviving adults and their numbers, together with field sampling of pre-adult stages in the rice fields.

5. DISCUSSION

The results of sterile male release programmes for mosquitoes so far have not been very encouraging, even though reasonable levels of sterility have been injected into natural populations. In fact, near total elimination has been achieved against C. quinquefasciatus and An. albimanus in small areas of Florida and El Salvador, respectively [51,53,54]. Total elimination, however, has not been achieved and the problems and limitations pertaining to this state of affairs have been discussed in detail by Weidhaas and Patterson [6] and Service [55]. Briefly, negative results have been attributed to the following factors:

- (1) Immigration of fertilized females into release areas,
- (2) Lower competitiveness of laboratory produced males,
- (3) Assortative mating resulting from behavioural pre-mating barriers,
- (4) Density dependent larval regulation,
- (5) Deterioration of genetic sexing mechanisms,
- (6) Adverse effects of prevailing weather conditions, e.g. change in the direction of prevailing winds or heavy downpours of rain,
- (7) Lack of effective barriers when releases are made in large inland areas as opposed to isolated islands, and
- (8) Lack of accurate knowledge of the actual numbers of the target population and the effective number of sterile laboratory males to be released.

Any future control trial in Mwea will have to contend with most of these problems, which, although recognized for a number of years now, have yet no solutions available.

A generally important prerequisite for genetic control programmes is sufficient knowledge of the genetics of the target organism. In An. arabiensis, considerable progress has been made in cytogenetics [44], but a great deal remains to be done in basic genetics. Also important is the unavailability of comprehensive ecological information, particularly on mating behaviour, life-history strategies and population dynamics. Most of these requirements are not met in the East African context, although unpublished data are available on the seasonal population dynamics of several mosquito species in Mwea, including An. arabiensis [56]. Other serious constraints include insufficient laboratory facilities and lack of trained personnel plus finances to back an expensive control trial operation such as the one proposed.

It is also appreciated that, up to now, there is no reliable and sound basis on which to predict the success or otherwise of genetic control trials. Future attempts, incorporating other control components, as suggested, may offer better chances of success.

ACKNOWLEDGEMENTS

Our work in the Mwea Irrigation Scheme and this presentation received support at various stages from the United States National Academy of Sciences, the International Atomic Energy Agency, through Research Contract No. 3272/RB, and the Deans' Committee, University of Nairobi.

REFERENCES

- [1] DAVIDSON, G., KITZMILLER, J.B., Application of new procedures to control: Genetic control of anophelines, Misc. Pub. Entomol. Soc. Am. 7 (1970) 118.
- [2] KITZMILLER, J.B., Genetic control of mosquitoes, Am. J. Trop. Med. Hyg. 21 (1972) 764.
- [3] ASMAN, S.M., McDONALD, P.T., PROUT, T., Field studies of genetic control systems for mosquitoes, Annu. Rev. Entomol. 26 (1981) 289.
- [4] KNIPLING, E.F., Possibilities of insect control or eradication through the use of sexually sterile males, J. Econ. Entomol. 48 (1955) 459.
- [5] KNIPLING, E.F., "Sterile technique: Principles involved, current application, limitations and future application", Genetics of Insect Vectors of Disease (WRIGHT, J.W., PAL, R., Eds.), Elsevier, New York (1967) 587-616.
- [6] WEIDHAAS, D.E., PATTERSON, R.S., "Control of mosquitoes by the sterile male technique", Sterile Insect Technique and Radiation in Insect Control (Proc. Symp. Neuherberg, 1981), IAEA, Vienna (1982) 67.
- [7] LAVEN, H., Eradication of Culex pipiens atigans through cytoplasmic incompatibility, Nature 216 (1967) 383.
- [8] BARR, A.R., "The Culex pipiens complex", Cytogenetics and Genetics of Vectors (Proc. 16th Int. Congr. Entomol. Kyoto, 1980) (PAL, R., KITZMILLER, J.B., KANDA, T., Eds.), Elsevier Biomedical, Amsterdam (1981).
- [9] SEAWRIGHT, J.A., "Chromosome aberrations for mosquito control", Biocontrol of Mosquitoes, AMCA Bull. No. 6 (1981).
- [10] SEAWRIGHT, J.A., KAISER, P.E., NARANG, S., "Chromosome manipulation studies of Anopheles albimanus", Cytogenetics and Genetics of Vectors (Proc. 16th Int. Congr. Entomol. Kyoto, 1980) (PAL, R., KITZMILLER, J.B., KANDA, T., Eds.), Elsevier Biomedical, Amsterdam (1981).
- [11] DAVIDSON, G., ODETOYINBO, J.A., COLUSSA, B., COZ, J., A field attempt to assess the mating competitiveness of sterile males produced by crossing two members of species of the Anopheles gambiae complex, WHO Bull. 42 (1970) 55.

- [12] SEAWRIGHT, J.A., NARANG, S., KAISER, P.E., "Use of genetics in insect control", Recent Developments in the Genetics of Insect Disease Vectors, Proc. Int. Symp. Bellagio, Italy, 1981.
- [13] SPIELMAN, A., Bionomics of autogenous mosquitoes, Annu. Rev. Entomol. 16 (1971) 231.
- [14] GILLIES, M.T., de MEILLON, B., The Anophelinae of Africa South of the Sahara (Ethiopian Zoogeographical Region), 2nd Edition, No. 54, South African Institute of Medical Research, Johannesburg (1968).
- [15] HADDOW, A.J., Mosquito fauna and climate of native huts at Kisumu, Kenya, Bull. Entomol. Res. 33 (1942) 91.
- [16] SERVICE, M.W., Ecological notes on species A and B of the Anopheles gambiae complex in the Kisumu area of Kenya, Bull. Entomol. Res. 60 (1970) 105.
- [17] SERVICE, M.W., Identification of the Anopheles gambiae complex in the Western Nyanza area, Kenya, 1971, WHO/VBC/72.362 (1972).
- [18] WHITE, G.B., The Anopheles gambiae complex and malaria transmission around Kisumu, Kenya, Trans. R. Soc. Trop. Med. Hyg. 66 (1972) 572.
- [19] JOSHI, G.P., SERVICE, M.W., PRADHAN, G.D., A survey of species A and B of the Anopheles gambiae Giles complex in the Kisumu area of Kenya prior to insecticidal spraying with OMS-43 (fenitrothion), Ann. Trop. Med. Parasitol. 69 (1975) 91.
- [20] SERVICE, M.W., JOSHI, G.P., PRADHAN, G.D., A survey of Anopheles gambiae (species A) and An. arabiensis (species B) of the An. gambiae Giles complex in the Kisumu area of Kenya following insecticidal spraying with OMS-43 (fenitrothion), Ann. Trop. Med. Parasitol. 72 (1978) 377.
- [21] HIGHTON, R.B., BRYAN, J.H., BOREHAM, P.F.L., CHANDLER, J.A., Studies of the sibling species Anopheles gambiae Giles and Anopheles arabiensis Patton (Diptera: Culicidae) in the Kisumu area, Kenya, Bull. Entomol. Res. 69 (1979) 43.
- [22] WHITE, G.B., Anopheles gambiae complex and disease transmission in Africa, Trans. R. Soc. Trop. Med. Hyg. 68 (1974) 278.
- [23] GRAINGER, W.E., The experimental control of mosquito breeding in ricefields in Nyanza Province of Kenya by intermittent irrigation and other methods, E. Afr. Med. J. 24 (1947) 16.
- [24] SURTEES, G., Studies on water movement and dispersion of mosquito larvae with special reference to control in ricefields, Bull. Entomol. Res. 60 (1970) 275.
- [25] SURTEES, G., SIMPSON, D.I.H., BOWEN, E.T.W., GRAINGER, W.E., Ricefield development and arbovirus epidemiology, Kano Plain, Kenya, Trans. R. Soc. Trop. Med. Hyg. 64 (1970) 511.

- [26] SURTEES, G., Large scale irrigation and arbovirus epidemiology, Kano Plain, Kenya, *J. Med. Entomol.* 7 (1971) 509.
- [27] SURTEES, G., Control of mosquitoes breeding in ricefields, *J. Trop. Med. Hyg.* 74 (1971) 255.
- [28] CHANDLER, J.A., HIGHTON, R.B., The succession of mosquito species (Diptera, Culicidae) in ricefields in the Kisumu area of Kenya, and their possible control, *Bull. Entomol. Res.* 65 (1975) 295.
- [29] CHANDLER, J.A., HIGHTON, R.B., HILL, M.N., Mosquitoes of the Kano Plain, Kenya, I. Results of indoor collections in irrigated and non-irrigated areas using human bait and light traps, *J. Med. Entomol.* 12 (1976) 504.
- [30] CHANDLER, J.A., HIGHTON, R.B., HILL, M.N., Mosquitoes of the Kano Plain, Kenya, II. Results of outdoor collections in irrigated and non-irrigated areas using human and animal bait and light traps, *J. Med. Entomol.* 13 (1976) 202.
- [31] GARNHAM, P.C.C., The role of Anopheles pharoensis Theobald in the transmission of malaria in Kenya colony, *Ann. Trop. Med. Parasitol.* 39 (1945) 63.
- [32] GILLET, J.D., The habits of the mosquito Aedes (Stegomyia) simpsoni Theobald in relation to the epidemiology of yellow fever in Uganda, *Ann. Trop. Med. Parasitol.* 45 (1951) 110.
- [33] GILLET, J.D., Yellow fever in East Africa, *E. Afr. Med. J.* 46 (1969) 22.
- [34] LUMSDEN, W.H.R., Entomological studies relating to yellow fever epidemiology at Gede and Taveta, Kenya, *Bull. Entomol. Res.* 46 (1955) 149.
- [35] HADDOW, A.J., SMITHBURN, K.C., MAHAFFY, A.F., BUGHER, J.C., Monkeys in relation to yellow fever in Bwamba County, Uganda, *Trans. R. Soc. Trop. Med. Hyg.* 40 (1947) 677.
- [36] TEESDALE, C., Studies on the bionomics of Aedes aegypti in its natural habitats in a coastal region of Kenya, *Bull. Entomol. Res.* 46 (1955) 711.
- [37] VAN SOMEREN, E.C.C., TEESDALE, C., FURLONG, M., The mosquitoes of the Kenya Coast: Records of behaviour, occurrence and habitat, *Bull. Entomol. Res.* 46 (1955) 463.
- [38] TRPIS, M., HAUSERMAN, W., Demonstration of differential domesticity of Aedes aegypti L. (Diptera: Culicidae) in Africa by mark-release-recapture, *Bull. Entomol. Res.* 65 (1975) 199.
- [39] TRPIS, M., HAUSERMAN, W., Genetics of house-entering behaviour in E. African populations of Aedes aegypti (Diptera: Culicidae) and its relevance to speciation, *Bull. Entomol. Res.* 68 (1978) 521.

- [40] PETERSEN, J.L., LOUNIBOS, L.P., LORIMER, N., Field trials of double translocation heterozygote males for genetic control of Aedes aegypti L. (Diptera: Culicidae), Bull. Entomol. Res. 67 (1977) 313.
- [41] McDONALD, P.T., HAUSERMAN, W., LORIMER, N., Sterility introduced by release of genetically altered males to a domestic population of Aedes aegypti at the Kenya Coast, Am. J. Trop. Med. Hyg. 26 (1977) 553.
- [42] TABACHNICK, W.J., POWELL, J.R., Genetic structure of the East African domestic population of Aedes aegypti, Nature 272 (1978) 535.
- [43] MUKIAMA, T.K., Gene polymorphism in sympatric populations of the yellow fever mosquito Aedes (Stegomyia) aegypti in Kenya, Kenya J. Sci. Technol. 1 (1980) 35.
- [44] COLUZZI, M., SABATINI, A., PETRARCA, V., DI DECO, M.A., Chromosomal differentiation and adaptation to human environments in the Anopheles gambiae complex, Trans. R. Soc. Trop. Med. Hyg. 73 (1979) 483.
- [45] MILES, S.J., A biochemical key to adult members of the Anopheles gambiae group of species (Diptera: Culicidae), J. Med. Entomol. 15 (1979) 297.
- [46] MAHON, R.J., GREEN, C.A., HUNT, R.H., Diagnostic allozymes for routine identification of adults of the Anopheles gambiae complex, Bull. Entomol. Res. 66 (1976) 25.
- [47] KITZMILLER, J.B., MASON, G.F., "Formal genetics of anophelines", Genetics of Insect Vectors of Disease (WRIGHT, J.W. PAL, R., Eds.), Elsevier, New York (1967) 3-15.
- [48] KITZMILLER, J.B., Genetics, cytogenetics and evolution of mosquitoes, Adv. Genet. 18 (1976) 315.
- [49] NARANG, S., SEAWRIGHT, J.A., "Linkage relationships and genetic mapping in Culex and Anopheles", Recent Developments in Genetics of Insect Disease Vectors (STEINER, W.W.M., RAI, K.S., NARANG, S., Eds.), Stipes Pub. Co., Champaign, IL (1982) 231-289.
- [50] LINES, J.D., AHMED, M.A.E., CURTIS, C.F., Genetic studies of malathion resistance in Anopheles arabiensis Patton (Diptera: Culicidae), Bull. Entomol. Res. 74 (1984) 317.
- [51] PATTERSON, R.S., et al., Release of radiosterilized males to control Culex pipiens quinquefasciatus, J. Med. Entomol. 14 (1977) 299.
- [52] MWANGI, R.W., MUKIAMA, T.K., The effects of Melia volkensii (Meliaceae) extracts against larvae of Anopheles arabiensis (unpublished).
- [53] LOFGREN, C.S., et. al., Release of chemosterilized males for the control of Anopheles albimanus in El Salvador: III. Field methods and population control, Am. J. Trop. Med. Hyg. 23 (1974) 288.

- [54] KAISER, P.E., BAILEY, D.L., LOWE, R.E., SEAWRIGHT, J.A., DAME, D.A., Mating competitiveness of chemosterilized males of a genetic sexing strain of Anopheles albimanus in laboratory and field tests, Mosq. News 39 (1979) 768.
- [55] SERVICE, M.W., "Ecological considerations regarding vector dynamics", Investigations in East Africa on the Feasibility of the Sterile Insect Technique (SIT) to Control the Anopheline Mosquito (Rep. Consultants Mtg Vienna, 1982), IAEA, Vienna, 1982.
- [56] MUKIAMA, T.K., MWANGI, R.W., Anopheles arabiensis and other anophelines of Mwea Irrigation Scheme, Kenya (unpublished).

Invited Paper

GENETIC METHODS FOR CONTROL OF MOSQUITOES AND BITING FLIES

J.A. SEAWRIGHT

Insects Affecting Man and Animals Laboratory,
Agricultural Research Service,
United States Department of Agriculture,
Gainesville, Florida,
United States of America

Abstract

GENETIC METHODS FOR CONTROL OF MOSQUITOES AND BITING FLIES.

The earliest research efforts on using genetic methods for the control of mosquitoes and biting flies concentrated on the evaluation of the sterile insect technique (SIT). Several successful, but generally small scale, research efforts with mosquitoes clearly documented that either chemosterilized or radiation sterilized males were effective in causing a level of genetic load that would be sufficient for the reduction or eradication of natural populations of several species. Genetic sexing strains of several species of mosquitoes have been assembled, and this aspect of breeding specialty strains is not a limiting factor in the implementation of SIT. In the largest field experiment, conducted with *Anopheles albimanus* in El Salvador during the 1970s, a genetic sexing strain was used operationally in a factory that produced one million sterile males per day over a one year period. Technical problems that would require extensive research of a practical nature before the implementation of SIT for mosquito control involve primarily better means for the rearing, sterilization and distribution of the insects. A successful experiment was conducted to eliminate the stable fly on the island of St. Croix, the United States Virgin Islands, and since this work in the 1970s, genetic sexing strains have been developed. A considerable amount of effort was expended on the synthesis of chromosome aberrations for the control of mosquitoes. Although the results of experimental trials indicated that aberration bearing insects could effectively inject a genetic load into the natural population, no large scale tests have ever been conducted to evaluate fully the real effectiveness of induced chromosomal aberrations. More recently, most of the research work in genetic control has been aimed at the use of recombinant DNA techniques for the development of new technology. All of these topics and an assessment of their value are discussed.

1. INTRODUCTION

This review will deal primarily with mosquitoes, with some comments on the stable fly, *Stomoxys calcitrans*, and there is no intention on the part of the author to present a comprehensive literature review of the subject areas. Instead, emphasis will be placed on (1) successful research efforts on use of the sterile insect technique (SIT) and the synthesis of useful heritable chromosomal aberrations, (2) the technical limitations in our present ability to use SIT, (3) the need for genetic evaluation of the structure of natural

populations, and (4) a look at the future impact of recombinant DNA methods on genetic control. A generally optimistic point of view of the current and future situations from the author's perspective will be expressed, with emphasis on successful research efforts. Past failures will not be ignored, but neither will they be presented as irrefutable evidence of doom for genetic control.

2. PAST SIT PROGRAMS

The earliest research efforts in the form of extensive laboratory and field evaluation on genetic methods for the control of mosquitoes concentrated on the evaluation of the sterile insect technique (SIT). In applying SIT, the rationale for control lies in the use of inundative releases of sterile males which produce gametes bearing one or more dominant lethals caused by a treatment with ionizing radiation or mutagenic chemicals. In practice, then, the degree of control is directly related to the genetic lethal load (=sterility) that is imposed on a population by matings between the sterilized and native insects. The lethal load does not persist in the population when releases of sterile insects are terminated. In general, the first experimental trials with mosquitoes employed an approach similar to the successful effort with the screwworm fly, Cochliomyia hominivorax. Radiation was used to sterilize laboratory reared mosquitoes, which were released into the natural habitat. The expected results, i.e. an increased genetic lethal load that would cause either population decline or control, were not achieved, and the negative results of these experiments led to the general conclusion that the use of radiation was not suitable because somatic damage was excessive (see Patterson et al. [1] for references). There were also obvious problems, fully documented in one case, with the release of laboratory adapted mosquitoes, in that the males did not mate with the wild females [2].

Dame [3] presented a comprehensive discussion of the basic requirements that are necessary for making SIT a workable solution to mosquito control a reality rather than just a fanciful idea. As he pointed out, it is very important to identify and solve the practical problems that are inherent in SIT, the goal of which is to use an 'insect factory' and automated production and distribution systems to rear, sterilize and distribute a sufficient number of sterile males that are competitive in mating with wild females. Success is also contingent upon the availability and understanding of basic knowledge of the biology and ecology of a species. If

one examines the earlier experiments with SIT for mosquito control, it is very easy to detect violations of several of the basic requirements outlined by Dame [3]. Of course, this was to be expected, for in retrospect, there were no clear guidelines for being successful in this type of research, because of the relative newness at that time.

Patterson et al. [4] demonstrated that it was possible to use radiation sterilized males for the induction of high genetic load into natural populations of Culex quinquefasciatus in two separate experiments, one in India and the other on Seahorse Key in Florida. Generally, if the males were irradiated at the end of the pupal stage or as young adults, the males were competitive enough (25-50 %) to have a significant effect on the reproductive ability of native mosquitoes. These experiments seemingly refuted some of the earlier results and definitely indicated that release of irradiated males was a viable means to obtain mosquito control or suppression.

Chemosterilants were tested in the earlier experimental phase of genetic control, but for the most part these highly mutagenic compounds were difficult to use for the sterilization of male mosquitoes, because in general they were effective sterilants only when fed to larvae or adults. Treatments of larvae usually caused excessive somatic damage, and feeding the adults was impractical. The situation with using chemosterilants changed drastically when White [5] discovered that thiotepa could be used to sterilize pupae of Aedes aegypti, and subsequent work provided structurally related sterilants that were even better [6].

The first successful small scale SIT experiment with a species of mosquito was conducted on the island of Seahorse Key, off the west coast of Florida, by Patterson et al. [7]. They controlled a population of Culex quinquefasciatus by overflowing a natural population with chemosterilized (treated with thiotepa) males.

In 1970, a large research effort designed to develop and test genetic control for mosquitoes was initiated in New Delhi, India, under the joint sponsorship of the World Health Organization and the Indian Council of Medical Research. This group of scientists did some outstanding research on radiosterilization, chemosterilization, rearing, ecology, cytoplasmic incompatibility and chromosomal aberrations over a period of about five years (see Rao [8] and the other papers in Vol. 6 of The Journal of Communicable Diseases for many of the significant references). Unfortunately, this program was terminated, partly because of political disagreements.

In the early 1970s, a successful experimental trial, resulting in the control of a relatively small, isolated population of Anopheles albimanus, was conducted at Lake Apastepeque in El Salvador by a team of USDA/ARS scientists [9]. This effort was followed by a much larger experimental trial [10], in a 150 km² area on the coastal plain of El Salvador in which releases of sterile males peaked at approximately one million sterile males per day for a period of one year. This pilot study was the largest on record and was deemed successful in terms of inducing sterility within the release zone, but migration of fertile females into the study area was a significant factor that mitigated population control. The release rate was not sufficient to have an effect over the entire 150 km² area, but a four month experiment in an area of c. 20 km² effectively controlled the breeding of A. albimanus. This large scale test was the first SIT experiment to make use of a genetic sexing strain, designated 'Macho'. Radiation was used to induce a translocation-inversion complex that linked propoxur resistance to the Y-chromosome. The females of this strain could be selectively killed by treatment with propoxur in the egg stage; thus, it was possible to rear only males, which cut the costs of production of sterile males in half.

Beginning in the 1960s, a small number of geneticists and entomologists with dual training began work in the area of heritable chromosomal aberrations (translocations, inversions, compound chromosomes, etc.) and lethal traits for the genetic control of mosquitoes. The basic ideas (and the original references) underlying the use of heritable genetic mechanisms and much of the progress in this area was reviewed by Seawright [11]. The most important advance that resulted from this type of genetic manipulation has been the production of genetic sexing strains [12], containing visible or conditional lethal mutants, which are constructed so that the females can be killed selectively. A full discussion of the advantages and usefulness of genetic sexing techniques can be found in a review by LaChance [13]. For mosquitoes, this has been relatively easy because of the availability of dominant insecticide resistance traits, which serve as selectable markers. The resistance gene is made holandric via the induction of a Y-linked reciprocal translocation; therefore, a strain can be made that is composed of resistant males and susceptible females. If there is a problem with 'leakage' of resistant females due to genetic recombination, this problem can be averted by the induction of an inversion, as demonstrated by Seawright et al. [12] in the assembly of the Macho strain of A. albimanus. As is the case with all research, luck will occasionally give the researcher a boost, as was the case for a genetic sexing strain of Anopheles

quadrimaculatus, species A, for which there was a malathion resistance gene that was located inside a naturally occurring paracentric inversion [14]. There was also a report by Sakai and Baker [15] on the use of a sex-linked temperature sensitive lethal trait for the synthesis of a genetic sexing strain for Culex tritaeniorhynchus.

Except for the use of the Macho strain in the large scale SIT test in El Salvador, there never have been any attempts to conduct large pilot or operational programs based on the release of mosquitoes bearing chromosomal aberrations constructed for the genetic control of a species. Several male linked translocations have been tested in limited competitive mating field trials with promising results (see review by Seawright [12]).

In a highly successful research effort, the stable fly, S. calcitrans, was virtually eradicated from the island of St. Croix, the United States Virgin Islands, through an integrated pest management program that employed the use of insecticides, releases of radiation sterilized males, and releases of parasitoids [16]. The SIT element was the key part of the program, and the results were a clear indication of the applicability of genetic control for this species. The only major problem is that both sexes of the stable fly are vicious biters, with the females being slightly more avid than the males. Half of this problem was solved by the synthesis of two types of genetic sexing systems. One system was based on a black pupa mutant [17], and the females can be separated mechanically from the males by using a commercial seed sorter. In the second system, a male linked translocation was employed to assemble a strain so that the males are resistant and the females susceptible to malathion; the females can be selectively killed by treatment of the eggs [18]. Laboratory efforts to isolate a non-biting male that can function normally in inseminating females have been pursued, but so far the results have been negative. Non-biting types have been produced, but they will not mate unless fed on a solution of blood (unpublished data).

3. TECHNICAL LIMITATIONS

The principal technical limitations involve three of the most important aspects of SIT, and for practical purposes these will also be of importance in the use of future types of genetic control. Since the basic principle of SIT involves overflooding the native population with sterile or genetically altered insects, the means must be available to mass produce,

sterilize and distribute sterile males that are vigorous and competitive. This must be done economically; otherwise, the methodology is not likely to receive favorable consideration, even if it is highly effective. This is a very demanding task, but as was demonstrated in the large scale experiment in El Salvador, there is some reason for optimism. In a recent conversation with David A. Dame, it was pointed out that by the time most of the problems had been solved with the technical limitations mentioned above, the funds for the project had been exhausted, so the project was abandoned at just the time when real progress was in the offing. From personal experience and interviews with scientists who have been involved in SIT research on a practical scale (i.e. pilot studies or larger, such as the screwworm and Mediterranean fruit fly programs), it takes time and considerable effort to discover and correct all of the seemingly minor problems that are in reality very important to the success of such an endeavor. The only way to detect all of the flaws in a system is to actually attempt to conduct large scale experiments that are very expensive and could end in failure, because of unanticipated complications and/or the lack of innovative personnel who can recognize and cope with technical details. There is no guarantee that a suitable system can be evolved that will meet all of the economic criteria, but unless a large scale effort is attempted, it is impossible to predict the outcome. It takes a great deal of fortitude and considerable political skill to organize and conduct expensive ventures that are regarded by many administrators and scientists as high risk technology, and if failure is the final outcome there can be serious consequences for the reputations and careers of the scientists.

In the past, the approach to mass production procedures used in all of the SIT evaluations have simply been an extension of the methods used for laboratory colonies. Instead of rearing one pan of larvae, virtually the same methods were used to produce one hundred pans. Of course, it is a logical manner by which mosquitoes can be reared for limited testing, but in the long run research on mass production will be required. The research should be aimed at (1) minimizing the detrimental effects of colonization on the gene pool, (2) standardized diets, (3) automation and (4) quality control.

Sterilization of the males has been and will continue to be a tricky step in the procedure, because male mosquitoes are fragile insects that are subject to debilitating damage with excessive handling. The use of radiation exacts a toll on competitiveness, but this is a minimal effect when young adults are irradiated. However, the adult stage is subject to more damage through handling. Pupae are easily sterilized by

treatment with chemosterilants, but there are tiny quantities of residues in the very young adults and this might have a detrimental effect on predators [19]. The residues persist for a short time, should not be hazardous to humans or domestic animals and should not accumulate in the food chain. Seawright et al. [20] found that the higher residues were related to the general health of the pupae, with vigorous insects having much smaller amounts in them, so superior rearing and handling would minimize this problem.

Distribution of the sterile males at the point where they can mate with native females is an area of research that has hardly been touched. Certainly, it will depend on the particular target species, but for most SIT programs the distribution of insects by means of aircraft is the most feasible alternative. Past efforts have been made using a combination of vehicles and on foot, and while release from a vehicle might work for urban situations, the use of aircraft should be studied for most species.

4. POPULATION GENETICS

The success of any genetic control system (past, present and future) depends on a sufficient knowledge of the target species and its distribution. One of the most significant mistakes that could be made would be to release sterile males of a single species into a complex of sympatric sibling species, because even if the SIT worked, only one sibling form would be affected. Sibling species complexes are common in the Culicidae and new descriptions of cryptic species appear in the literature on a regular basis. The available taxonomic keys are usually of no value in discovering sibling species. The only useful way to study whether a complex exists is through genetic and biochemical analyses involving the use of hybridization crosses, polytene chromosomes, allozymes, diagnostic DNA probes, mitochondrial DNA and cuticular hydrocarbons. We have used all of these methods in our work with the A. quadrimaculatus complex to uncover and develop simple diagnostic tests for identifying the four morphologically indistinguishable species that have so far been found in natural populations. After working with these techniques, we have determined that, as with other organisms, allozyme and mtDNA analysis is most appropriate for the initial screen of a species of anopheline mosquito.

5. MOLECULAR BIOLOGY - THE FUTURE

Cockburn et al. [21] reviewed the status of molecular biology and the potential for applying these techniques in the

genetic control of economically important insects. An update of this review was recently finished and should appear soon [22]. Some of the problems encountered in designing operational systems should be more easily solved by a molecular approach than by conventional genetic and cytogenetic methods. The use of classical genetic approaches involving the use of radiation and chemical mutagens to induce useful mutants and chromosomal aberrations followed by a breeding program to construct useful strains is a laborious, expensive process that is not always successful. Although there is some opposition [23] to the 'stampede' in the direction of recombinant DNA techniques for the development of future genetic control systems, it is time to accept the reality that molecular biology is going to revolutionize our concepts in most biological and agricultural areas. As mentioned above, there are some perfectly good indications that we could control some species of mosquitoes, and certainly the stable fly is vulnerable, with practical improvements of our present knowledge of SIT. However, I think that anyone interested in the possibility of improvement in our present situation should read Cockburn et al. [21] and Cockburn and Seawright [22] and then proceed to become familiar with the literature that describes how to actually manipulate genes. Although it should be obvious, perhaps it is prudent to point out that the basic and applied research required to use recombinant DNA technology for developing novel genetic control systems will be demanding, expensive and sophisticated. The real benefits are in the future, and this fact must be remembered before embarking on research in this area.

The extensive literature on Drosophila melanogaster serves as a guide for those researchers working on genetic control technology. D. melanogaster is the best understood eukaryote in terms of genetics and cytogenetics, and the recent work on the molecular biology of this species should now serve quite well as a guide to the application of recombinant DNA techniques in the synthesis of novel genetic control systems for applied entomology. The progress in microbial genetics led to the development of extensive manipulation of the genome of D. melanogaster, and in turn this species is the model for genetic control specialists. Probably, the work on molecular genetics of pests should proceed first with those few species for which there is enough basic genetic and cytogenetic knowledge to provide tools (such as mutants, linkage group maps, polytene chromosome maps and chromosomal aberrations) that should be very useful in genome manipulation. This approach may be advisable in the synthesis of the first genetic control systems based on molecular manipulations, but in the long run, one of the attractive features of the

molecular approach is the possibility that it may be applicable to pests for which only a limited amount of basic knowledge is available.

From research on D. melanogaster, complete methods are now available for the extraction of total DNA, digestion of this DNA into fragments of known lengths and packaging of the DNA fragments into vectors for the establishment of genomic libraries [24]. Reliable techniques, using probes, are suitable for screening the genomic library for the DNA sequence that contains a particular gene of interest. Hundreds of genes of D. melanogaster have been cloned, and currently these clones represent the most easily obtainable probes for identifying a particular gene in a genomic library. The reader is referred to Cockburn et al. [21] for appropriate references.

Germ-line transformation of D. melanogaster was the most significant of the recent advances in the molecular genetics of insects in terms of demonstrating the technology for the use of a molecular approach in genetic control research. Techniques for the transformation of prokaryotes and tissue cells have been available for some time, but the transformation of a eukaryote by Rubin and Spradling [25] by microinjection of DNA clones into eggs provides methodology that has direct application in the development of genetic control. The description of transposable genes, viz. the P elements [26], in D. melanogaster was the key to their success in germ-line transformation. Transposable elements can transpose from one site on a chromosome to another and this ability to transpose was used to effect transformation. A clone of a gene was inserted into a deleted P element and this new hybrid clone was coinjected along with a clone of a functional P element into the eggs of the target germ line. A clone of a hybrid gene made up of a heat shock gene, the rosy gene and a P element of D. melanogaster and the beta-galactosidase gene of E. coli was used successfully in a more recent transformation experiment [27]. This experiment is particularly encouraging to researchers doing genetic control work because it means that the promoter regions of genes can be used in hybrid constructs and used to elicit, on demand of the condition, the activity of a trait introduced into another genome by transformation.

Efforts are under way to effect germ-line transformation of mosquitoes. So far, very limited success was achieved with Anopheles gambiae by Miller et al. [28] in an experimental setup where they tried to use the P element system of D. melanogaster to mediate transformation. Apparently, the P element does not function in the mosquito embryo, since they

only recovered one transformant out of several thousand eggs injected. This result was not surprising. O'Brochta and Handler [29] reported a lack of excision of the P element injected into the eggs of Anastrepha suspensa (Caribbean fruit fly) and Toxotrypana curvicauda (papaya fruit fly). In my research group, Tarrant and Cockburn (unpublished data) did not find any evidence for the presence of DNA sequences homologous to the P element in natural populations of several species of mosquitoes and the stable fly. Due to the results of Miller et al. [28] and the negative results in the screen for P element, our group is now screening for transposable elements in anopheline mosquitoes by examining middle-repetitive DNA sequences that differ between sibling species. So far, we have not found any useful transposable elements, but DNA probes that are specific for a given sibling species were a byproduct of this work; these are useful for quick identification of sibling forms through the use of a blot technique. We are also investigating the particle gun described by Klein et al. [30] as a means for introducing genes into the nuclei of the cells of mosquito embryos and an experiment is under way to try to induce transformation through the activation of DNA repair systems with radiation. Needless to say, it is of utmost importance to develop methods for effecting transformation, because otherwise it will be impossible to synthesize strains that can be used for genetic control.

The emphasis in my group's research program is the utilization of the molecular approach for the synthesis of genetic control systems and the ultimate application of these genetic manipulations in operational control programs. There are also applications for molecular biology in biological control, evolution, insecticide resistance and other areas. It should be defined at this point that in regard to the use of recombinant DNA techniques for pest control, there are a vast number of possible alternatives, and the selection of a particular scheme for the synthesis of a control system should be based on how much information is available on that pest. Once transformation is available, the other technology is already at hand to make strains that can be genetically sexed and sterilized by imposition of a condition, e.g. temperature. For examples of just a few of the possibilities, the reader is referred to Cockburn et al. [21]. There are so many different ways to approach using molecular techniques in the development of genetic control technology that the only limitations are the imagination of the scientists and the funding available for this work. In my own personal view, I do not think that this approach to pest control is a high risk venture. Instead, I think that adequate funding of directed efforts will be successful.

REFERENCES

- [1] PATTERSON, R.S., et al., Release of radiosterilized males to control Culex pipiens quinquefasciatus (Diptera: Culicidae), J. Med. Entomol. 14 (1977) 299.
- [2] DAME, D.A., WOODARD, D.B., FORD, H.R., and WEIHAAS, D.E., Field behavior of sexually sterile Anopheles quadrimaculatus males, Mosq. News 24 (1964) 6.
- [3] DAME, D.A., Genetic control by sterilized mosquitoes, Am. Mosq. Cont. Assoc. Bull. No. 6 (1985) 159.
- [4] PATTERSON, R.S. et al., Use of radiosterilized males to control indigenous populations of Culex pipiens quinquefasciatus Say: Laboratory and field studies, Mosq. News 35 (1975) 2.
- [5] WHITE, G.B., Chemosterilization of Aedes aegypti (L.) by pupal treatment, Nature 210 (1966) 1372.
- [6] SEAWRIGHT, J.A., BOWMAN, M.C., and LOFGREN, C.S., Insect chemosterilants: gas chromatography, p-values, and relationship of p-values to sterilant activity in pupae of Anopheles albimanus, J. Econ. Entomol. 66 (1973) 613.
- [7] PATTERSON, R.S., WEIDHAAS, D.E., FORD, H.R., and LOFGREN, C.S., Suppression and elimination of an island population of Culex pipiens quinquefasciatus with sterile males, Science 168 (1970) 1368.
- [8] RAO, T.R., Research on genetic control of mosquitoes in India: Review of the work of the WHO/ICMR research unit, New Delhi, J. Commun. Dis. 6 (1974) 57.
- [9] LOFGREN, C.S. et al., Release of chemosterilized males for the control of Anopheles albimanus in El Salvador. III. Field methods and population control, Am. J. Trop. Med. Hyg. 23 (1974) 288.
- [10] DAME, D.A., LOWE, R.E., and WILLIAMSON D.L., "Assessment of released sterile Anopheles albimanus and Glossina morsitans morsitans", Cytogenetics and Genetics of Vectors (Proc. XVI Int. Congr. Entomol. Kyoto, 1980) (KITZMILLER, J.B., KANDA, T., Eds), Elsevier Biomedical, Amsterdam (1981) 231-241.
- [11] SEAWRIGHT, J.A., Genetic control by chromosome aberrations, Am. Mosq. Cont. Assoc., Bull. No. 6 (1985) 173.
- [12] SEAWRIGHT, J.A., KAISER, P.E. DAME, D.A., LOFGREN, C.S., Genetic method for the preferential elimination of females of Anopheles albimanus, Science 200 (1978) 1303.

- [13] LACHANCE, L.E., "Genetic strategies affecting the success and economy of the sterile insect release method", Genetics in Relation to Insect Management (Proc. Rockefeller Foundation Conference) (HOY, M.A., MCKELVEY, J.J., Eds), Rockefeller Foundation, New York (1979) 8-18.
- [14] KIM, S.S., SEAWRIGHT, J.A., and KAISER, P.E., A genetic sexing strain of Anopheles quadrimaculatus species A, J. Am. Mosq. Cont. Assoc. 3 (1987) 50.
- [15] SAKAI, R. K. and BAKER, R.H., Induction of heat sensitive lethals in Culex tritaeniorhynchus by ethyl methanesulfonate, Mosq. News. 34 (1974) 420.
- [16] PATTERSON, R.S., LABRECQUE, G.C., WILLIAMS, D.F., and WEIDHAAS, D.E., Control of the stable fly, Stomoxys calcitrans (Diptera:Muscidae), on St. Croix, U.S. Virgin Islands, using integrated pest management measures. III. Field techniques and population control, J. Med. Entomol. 21 (1984) 179.
- [17] SMITTLE, B.J., SEAWRIGHT, J.A., BIRKY, B.K., Use of a commercial color sorter to separate sexes of stable fly (Diptera:Muscidae) pupae from a genetic sexing strain, J. Econ. Entomol. 79 (1986) 877.
- [18] SEAWRIGHT, J.A., BIRKY, B.K., and SMITTLE, B.J., Use of a genetic technique for separating the sexes of the stable fly (Diptera:Muscidae), J. Econ. Entomol. 79 (1986) 1413.
- [19] BRACKEN, G.K. and DONDALE, C.D., Fertility and survival of Achaeasanea tepidariorum (Araneida:Theridiidae) on a diet of chemosterilized mosquitoes, Can. Entomol. 104 (1972) 1709.
- [20] SEAWRIGHT, J.A., BOWMAN, M.C. and DAME, D.A., Stability of an aqueous solution of P,P-bis(1-aziridinyl)-N-methylphosphinothioic amide used to sterilize pupae of Anopheles albimanus, J. Econ. Entomol. 67 (1974) 337.
- [21] COCKBURN, A.F., HOWELLS, A.J., and WHITTEN, M.J., Recombinant DNA technology and genetic control of pest insects, Biotech. Genet. Eng. Rev. 2 (1984) 69.
- [22] COCKBURN, A.F. and SEAWRIGHT, J.A., "Application of molecular genetics to insect control", Handbook of Natural Pesticides: Insects, Vol. III, Plenum Press (in press).
- [23] CURTIS, C.F., Genetic control of insect pests: Growth industry or lead balloon? Biol. J. Linnean Soc. 26 (1985) 359.

- [24] MANIATIS, T., FRITSCH, E.F., and SAMBROOK, J., Molecular Cloning. A Laboratory Manual, Cold Spring Harbor, New York (1982).
- [25] RUBIN, G.M., and SPRADLING, A.C., Genetic transformation of Drosophila with transposable element vectors, Science 218 (1982) 348.
- [26] RUBIN, G.M., KIDWELL, M.G., and BINGHAM, P.M., The molecular basis of P-M hybrid dysgenesis. The nature of induced mutations, Cell 29 (1982) 987.
- [27] LIS, J.T., SIMON, J.A., and SUTTON, C.A., New heat shock and B-galactosidase activity resulting from transformation of Drosophila with an hsp70-lacZ hybrid gene, Cell 35 (1983) 403.
- [28] MILLER, L.H., et al., Stable integration and expression of a bacterial gene in the mosquito Anopheles gambiae, Science 237 (1987) 779.
- [29] O'BROCHTA, D.A. and HANDLER, A.M., Mobility of P elements in drosophilids and nondrosophilids, Nature (in press).
- [30] KLEIN, T.M., WOLF, E.D., WU, R., and SANFORD, J.C., High velocity microprojectiles for delivering nucleic acids into living cells, Nature 327 (1987) 70.

GENETIC APPROACHES TO INSECT CONTROL (cont.)

(Session 4)

Chairman

M.J. WHITTEN

Australia

Invited Paper

TEMPERATURE DEPENDENT SEX RATIO DISTORTION AFTER X-IRRADIATION OF MEDFLY MALES

R.J. WOOD, R.M. SHAHJAHAN
Department of Environmental Biology,
University of Manchester,
Manchester,
United Kingdom

Abstract

TEMPERATURE DEPENDENT SEX RATIO DISTORTION AFTER X-IRRADIATION OF MED-FLY MALES.

An inherited factor, thought to be a mutation induced by irradiation of male pupae with 1.4 krad of X-rays, causes excess male production in the progeny of males inheriting it. The gene appears to be an example of meiotic drive and is sensitive to temperature: parents kept at $18^{\circ} \pm 1.5^{\circ}\text{C}$ from age 72–96 h of pupal development gave rise to significantly more distorted sex ratios in their progeny than parents raised during the same period at the normal laboratory temperature of $26^{\circ} \pm 2.0^{\circ}\text{C}$. Taking advantage of the low temperature effect, single pair families showing the greatest sex ratio distortion have been used to start new lines. Progress in selecting strains with distorted sex ratios is reported and the potential of the gene for constructing a genetic sexing system is discussed.

INTRODUCTION

The sex ratio studies reported here began with a series of experiments designed to produce a translocation of an insecticide resistance gene onto the Y chromosome. Insecticide resistant strains of the medfly, *Ceratitis capitata* Wied., were isolated by laboratory selection, and resistance was shown to segregate as a major autosomal gene [1,2]. A breeding programme, involving irradiation with X-rays and screening with insecticides, aimed at producing an appropriate translocation of this gene, was unsuccessful in its primary objective [3]. It did, however, reveal variation in sex ratio in the progeny of single pair matings which was investigated in succeeding generations [3]. The families showing the greatest excess of males were used to found separate strains, and in one of these (A425) sex ratio continued to be significantly distorted for 55 generations. This strain was used to found other strains (see Materials and Methods below) in which the sex ratio was more distorted, although there was considerable fluctuation between generations [3].

Research has been directed towards determining the basis of the sex ratio distortion and the cause of the variability observed. Evidence reported by Wood and Shahjahan [4] pointed to a gene acting prezygotically, possibly a meiotic drive gene, the effect of which was enhanced by keeping the parents at a relatively low temperature (18-23°C) during development. No evidence could be found that temperature influenced sex ratio in the same generation. Here we report progress made in investigating the temperature effect in more detail, and describe ongoing experiments aimed at producing strains showing a more extreme excess of males.

MATERIALS AND METHODS

The strains referred to are as follows:

DiR: a substrain of SOUTHAMPTON, probably of Hawaiian origin, selected for high larval resistance to dieldrin and showing cross resistance to malathion. SOUTHAMPTON was obtained from Dr. P. Howse, Southampton University, UK.

DiS: a substrain of COSTA RICA, selected for larval susceptibility to dieldrin and also susceptible to malathion. COSTA RICA was obtained from Dr. E. Boller, Wädenswil, Switzerland.

A425: the procedure for isolating strain A425 began with X-irradiation of a sample of pupae of DiR. These were exposed at age 7 days to 1.4 krad of X-rays (at 120 rad per minute).¹ Use was made of a PANTAK 300K X-ray generator operating at 300 kV, 10 mA, located at the Paterson Laboratories, Manchester. The experimental set-up was designed to give a dose rate of 120 rad/min at the sample by placing it 20 cm from the tube. The generator had been modified by the addition of a flattening filter which gave a uniform field of 12 cm diameter. The uniformity was ± 0.02 .

Irradiated DiR males were crossed to unirradiated DiS females and the F_1 males backcrossed to DiS females by single pair matings. Before backcrossing, the F_1 had been screened at the third larval instar with 20 ppm malathion (a discriminating dose designed to remove susceptible segregants), the survivors being used for the backcrosses. The backcross families were again screened

¹ 1 rad = 1.00×10^{-2} Gy.

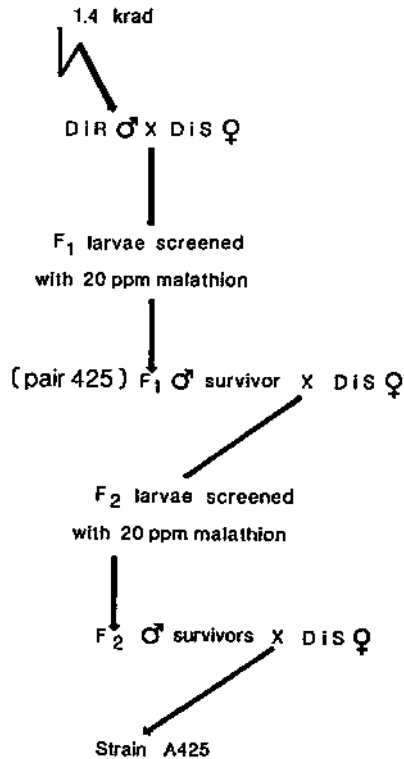

FIG. 1. Breeding scheme by which strain A425 was derived.

with malathion at F₂. Among these, the eight survivors in F₂ 425 (all male) were mass crossed to DiS females. The procedure is summarized in Fig. 1. The resulting F₃ was used to start strain A425, the sex ratio of which was investigated in the next and subsequent generations without selection [3]. The maximum sex ratio distortion observed in A425 in a large sample was 35.3%♀ (n=954) in generation 26, but there was considerable fluctuation between generations; sex ratio stabilized in later generations (40-55) at around 46%♀.

B39: this was derived from a single pair mating within A425 F₁₃. It showed wide fluctuation in sex ratio between generations and a maximum distortion of 18.0%♀ (n=762).

TABLE 1. SEX RATIO IN STRAIN C10 IN THE PROGENY (F_{29}) OF PARENTS (F_{28}) REARED DURING DIFFERENT STAGES OF PUPAL DEVELOPMENT AT $18^{\circ}\pm 1.5^{\circ}\text{C}$ AND THE REMAINDER AT $26^{\circ}\pm 2.0^{\circ}\text{C}$. PREPUPAE WERE COLLECTED ON DAY 0. REPLICATES WERE FROM SEPARATELY REARED LARVAE

	F_{28} Pupal age (days) of treatment at 18°C	F_{29}		
		Replicates	Number	% \pm S.E.
	2.7 - emergence	5	4350	34.0 \pm 1.8
Includes days 3-4 (72-96 h)	2.7 - 4.7	3	2599	29.6 \pm 1.9
	2.7 - 5.7	5	5735	30.5 \pm 2.7
	2.7 - 7.7	3	3118	36.1 \pm 1.7
	2.7 - 9.7	3	2449	36.0 \pm 4.0
	4.7 - 7.7	2	2199	39.0 \pm 0.6
Does not include days 3-4 (72-96 h)	4.7 - emergence	2	2197	42.5 \pm 3.5
	6.7 - emergence	2	1988	44.7 \pm 1.5
	7.7 - emergence	2	2195	45.6 \pm 0.5
	8.7 - emergence	2	2362	47.0 \pm 0.4
	10.7 - emergence	4	4498	45.9 \pm 2.3
	6.7 - 9.7	3	2657	46.7 \pm 0.1

C10: this was derived from a single pair mating with B39 F_2 . Sex ratio fluctuated around 38% ϕ for 15 generations, with a maximum distortion of 23.2% ϕ (n=1235). At the time of the experiments reported here (generations 29-31), it ranged from 39-46% ϕ .

Families D13 and D73, which are referred to in this account, were taken from C10. Families E38 and E39 were taken from D13. Rearing was normally carried out in insectary rooms at $26^{\circ}\pm 2^{\circ}\text{C}$ and 55 \pm 5% RH. The low temperature treatments were given in cabinets maintained at $18^{\circ}\pm 1.5^{\circ}\text{C}$.

RESULTS

Studies directed towards identifying as precisely as possible the time during development when the low temperature treatment had its maximum effect on sex ratio in the next generation were carried out on strain C10. Treatments at $18^{\circ}\pm 1.5^{\circ}\text{C}$ were given in generations 28 and 30 during different periods of pupal life. Each treatment was replicated. Sex ratio was investigated in generations 29 and 31. Data from the two experiments are given in Tables I and II and in Fig. 2. They establish that the critical period for low temperature

TABLE II. SEX RATIO IN STRAIN C10 IN THE PROGENY (F_{31}) OF PARENTS (F_{30}) REARED DURING DIFFERING STAGES OF F_{30} PUPAL DEVELOPMENT AT $18^{\circ}\pm 1.5^{\circ}\text{C}$ AND THE REMAINDER AT $26^{\circ}\pm 2.0^{\circ}\text{C}$ COMPARED WITH A CONTROL REARED FOR THE WHOLE OF PUPAL DEVELOPMENT AT $26^{\circ}\pm 2^{\circ}\text{C}$. PREPUPAE WERE COLLECTED ON DAY 0. REPLICATES WERE FROM SEPARATELY REARED LARVAE

	F_{30} Pupal age (days) of treatment at 18°C	F_{31}		
		Replicates	Number	% \pm S.E.
	0-5	12	13 813	39.2 \pm 0.5
	0-7	12	12 987	40.4 \pm 0.3
Includes days 3-4 (72-96 h)	1-6	12	13 185	40.9 \pm 0.5
	1-8	12	13 985	39.8 \pm 0.8
	2-4	12	14 174	40.2 \pm 0.4
	2-7	12	13 549	40.2 \pm 0.3
	2-9	12	12 754	38.7 \pm 0.2
Does not include days 3-4 (72-96 h)	0-2	12	13 291	45.2 \pm 0.8
	1-3	12	13 369	43.2 \pm 0.7
	no treatment (control)	12	13 823	43.6 \pm 0.4

treatment was from days 3-4 (72-96 hours) of pupal development (the jumping larvae (prepupae) having been isolated on day 0). The critical period is therefore quite narrow, although there is possibly a little leeway beyond 96 hours in some cultures (note the exposure 4.7-7.7 days in Table I).

After treatment of pupae during the critical period, the sex ratio in the next generation varied from 29.6 \pm 1.9% ϕ - 36.1 \pm 1.68% ϕ in experiment 1 and from 38.7 \pm 0.2 - 40.9 \pm 0.5% ϕ in experiment 2, compared with 42.5 \pm 2.5 - 47.0 \pm 0.4% ϕ in samples not treated at 72-96 hours. The difference was highly significant in both cases although greater in experiment 1. The two experiments were apparently similar in design and execution and the reason for the difference between the two sets of results is not yet clear.

Taking advantage of the effect of low temperature treatment, attempts were made to select single pair families with specially distorted sex ratios in order to found new strains which, it was hoped, would be consistently distorted to a higher degree than had been possible before. The first results, based on two experiments, are reported here. In each case, parents were treated at $18^{\circ}\pm 1.5^{\circ}\text{C}$ during the critical period, after

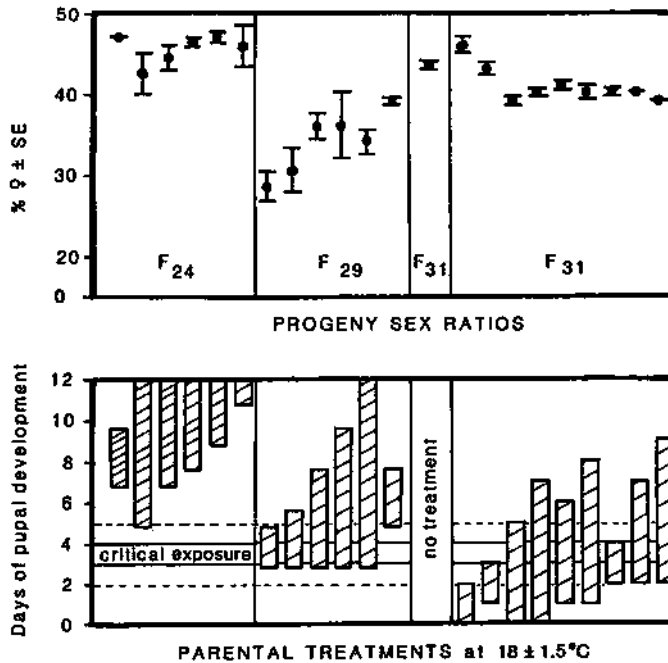

FIG. 2. Sex ratios in the progeny of individuals of strain C10 which had been maintained for various periods of pupal development at $18^{\circ} \pm 1.5^{\circ}\text{C}$, the remainder of development having been at $26^{\circ} \pm 2.0^{\circ}\text{C}$.

which sex ratio was recorded in the F_1 (which was not temperature treated) and then recorded again in the F_2 which was produced by mass mating the F_1 . Data on the most distorted sex ratios in the two experiments are shown in Fig. 3. A clear relationship was evident between F_1 and F_2 . One of the lowest sex ratios recorded in F_1 (with the benefit of low temperature treatment) was 21.4%♀ (n=42) in D13 and in F_2 (without the benefit of the treatment) it was 29.0%♀ (n=69). E39 (22.1%♀ (n=95) in F_1) was derived from D13 and is currently the subject of further investigation by inbreeding and selection.

DISCUSSION

The critical period for the low temperature effects on sex ratio has now been identified as 72-96 hours into pupal development. The timing of the effect points to sex ratio distortion being related to a disturbance at meiosis rather than spermiogenesis, i.e. the mechanism being one of true meiotic drive.

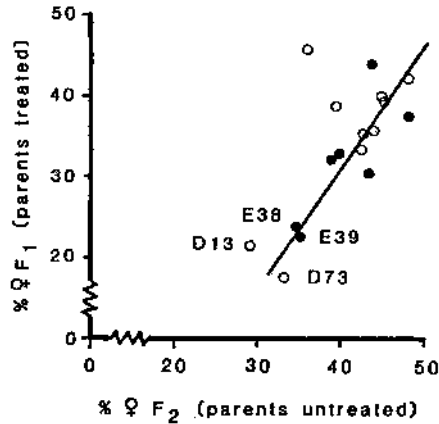

FIG. 3. Sex ratios in F_1 from single pair matings of individuals treated during the critical period of pupal development at $18^\circ \pm 1.5^\circ\text{C}$ plotted against the sex ratio in the corresponding F_2 , obtained by mass mating untreated F_1 .

It is supposed that the meiotic drive factor was induced as a mutation in the originally irradiated DiR male. The conclusion is based on evidence from a series of 138 control families from the same crossing scheme (but with the male not irradiated), in which sex ratio distortion was not observed. Nevertheless, the possibility cannot be excluded that this factor occurs as a rare natural variant. Malacrida et al. [5] have found naturally occurring sex ratio distorting genes in *C. capitata* associated with markers on two different linkage groups. Whether either of these two genes is related to the present one is not yet clear, and there is room for further investigation in this area.

If our gene was induced by the X-ray treatment, it must have been a dominant, or partially dominant, mutation. The breeding scheme (with three generations of outcrossing) was such as to exclude a recessive mutation from being expressed. Equally, the breeding scheme excluded the possibility of any induced change to the X chromosome. We are left therefore with a dominant, or partially dominant, mutation, either on the Y chromosome or one of the autosomes.

An hypothesis of Y-linked meiotic drive is compatible with observations so far. That such a system can maintain a distorted sex ratio for many generations has been demonstrated in studies on the Y-linked *D* (distorter) gene in *Aedes aegypti* [6,7]. Given sufficient sensitivity, extreme sex ratios are possible with such a system. In *Ae. aegypti*, strains have shown sex ratios consistently less than 6% females [8].

The above example relates to a genetic variant occurring naturally in wild populations. Examples of male biased sex ratios arising after irradiation are also recorded, but the explanation is different in these cases. Thus Catcheside and Lea [9] found a bias in favour of males in the progeny of irradiated males of D. melanogaster mated to wild type females which was shown to be due to extra damage to X spermatozoa which was not sustained by Y spermatozoa. A similar explanation was given for the same observation made in the tsetse fly Glossina morsitans [10]. However, this explanation cannot be applied in the present case of male excess because sex ratio distortion has been observed after three generations of outcrossing and therefore irradiated X chromosomes are excluded from consideration.

Another example from the literature is a meiotic drive gene (RD) which was isolated in Drosophila melanogaster after chronic irradiation by Novitski and Hanks [11]. This was X-linked, led to a disruption of the Y chromosome and was temperature sensitive. This, of course, gave a female-distorted sex ratio.

The genetic basis of the present sex ratio distorting factor should become clear after further study. Our first aim is to produce a strain with a consistently distorted sex ratio showing minimum fluctuation between generations. Use of the temperature effect should allow the expression of the gene to be brought under closer control.

This project is related to the production of a genetic sexing system for the medfly and is sponsored by the Joint FAO/IAEA Division. Theoretically, a temperature dependent meiotic drive gene is an attractive proposition for genetic sexing since it permits the effect to be induced in a very simple way. More work is now required to evaluate it.

ACKNOWLEDGEMENTS

This work was carried out under Ministry of Agriculture, Fisheries and Food licence No. PHF 250/72 and Joint FAO/IAEA Technical Contract No. 2488/TC. R.M.S. was supported by a Commonwealth Scholarship. The typescript was patiently prepared by Mrs. S.E. Hardman and the figures by Mr. David Ward. We are indebted to Drs E. Boller and P. Howse for strains of the medfly on which this study was based.

REFERENCES

- [1] BUSCH-PETERSEN, E., WOOD, R.J., "Insecticide resistance as a prospective candidate for the genetic sexing of the Mediterranean fruit fly Ceratitis capitata (Wied.)",

- Fruitflies of Economic Importance (Proc. Symp. Athens, 1982) (CAVALLORO, R., Ed.), Balkema, Rotterdam (1982) 182.
- [2] BUSCH-PETERSEN, E., WOOD, R.J., The isolation and inheritance of dieldrin resistance in the Mediterranean fruit fly Ceratitis capitata (Wiedemann) (Diptera: Tephritidae), Bull. Entomol. Res. 76 (1986) 567.
- [3] WOOD, R.J., SAAID, S.S., SHAHJAHAN, R.M., SOUTHERN, D.I., "Excess male production in lines of the Mediterranean fruit fly Ceratitis capitata (Wied) isolated after X irradiation followed by outcrossing", Fruitflies (Proc. Int. Symp. Crete, 1986) (ECONOMOPOULOS, A.P., Ed.), Elsevier, Amsterdam (1986) 179.
- [4] WOOD, R.J., SHAHJAHAN, R.M., "Temperature dependant sex ratio distortion after X-irradiation of Ceratitis capitata males", Fruitflies of Economic Importance (Proc. Int. Symp. Rome, 1987) (CAVALLORO, R., Ed.), Balkema, Rotterdam (in press).
- [5] MALACRIDA, A.R., GASPERI, G., MILANI, R., "Genome organisation of Ceratitis capitata: linkage groups and evidence for sex ratio distorters", Fruitflies (Proc. Int. Symp. Crete, 1986) (ECONOMOPOULOS, A.P., Ed.), Elsevier, Amsterdam (1986) 169
- [6] HICKEY, W.A., CRAIG, G.B., Distortion of sex ratio in populations of Aedes aegypti, Can. J. Genet. Cytol. 8 (1966) 260.
- [7] WOOD, R.J., OUDA, N.A., The genetic basis of resistance and sensitivity to the meiotic drive gene D in the mosquito Aedes aegypti L., Genetica 72 (1987) 69.
- [8] PEARSON, A.M., WOOD, R.J., Combining the meiotic drive gene D and the translocation T, in the mosquito Aedes aegypti (L). 1. Sex ratio distortion and fertility, Genetica 51 (1980) 203.
- [9] CATCHESIDE, D.G., LEA, D.E. The rate of induction of dominant lethals in Drosophila melanogaster by X rays, J. Genet. 47 (1945) 1.
- [10] CURTIS, C.F., et al., Sex ratio distortion and semi-sterility in the progeny of irradiated Glossina morsitans, Genet. Res. 21 (1973) 153.
- [11] NOVITSKI, E., HANKS, G.D., The analysis of irradiated Drosophila populations for instances of meiotic drive, Nature 190 (1961) 989.

GENETIC METHOD FOR SEPARATION OF MALES AND FEMALES OF THE MEDFLY ON THE BASIS OF PUPAL COLOUR

J.M.M. WALDER

Centro de Energia Nuclear na Agricultura,

Universidade de São Paulo,

Piracicaba, São Paulo,

Brazil

Abstract

GENETIC METHOD FOR SEPARATION OF MALES AND FEMALES OF THE MEDFLY ON THE BASIS OF PUPAL COLOUR.

A genetic sexing strain of the Mediterranean fruit fly (medfly), *Ceratitidis capitata* (Wied.), with females having black pupal colour and males brown pupal colour, has been obtained. Translocations were induced in adult males which were 48 h old from the normal strain at a gamma radiation dose of 55 Gy. Use of this strain in integrated control programmes using sterile male releases seems very promising and this possibility should be analysed.

1. INTRODUCTION

The Mediterranean fruit fly (medfly), *Ceratitidis capitata* (Wied.), is one of the major fruit pests in Brazil. At present, the medfly is controlled using pesticide baits. In citrus crops, the baits are applied about twenty times during fruit maturation. The sterile insect technique (SIT) methodology will be a good tool in an integrated pest management programme to reduce pest populations to very low levels.

The sterile female is less effective than the sterile male in a suppression programme [1]. In addition, the sterile females of *C. capitata* cause oviposition damage to the fruits. Therefore, removal of the females prior to release is very advantageous.

The use of the pupal colour sexing system for medfly control using the sterile male technique (SMT) should be considered. Sterile males could be released and the female pupae could be used to rear pupal microhimenopteran parasites such as *Muscidifurax raptor* [2] and/or *Spalangia endius* [3]. A combination of these two methods (parasites and SMT) might be an excellent approach to the suppression of the house fly [4] and the medfly.

Rössler was the pioneer in genetic sexing methodology with the medfly, using a dark pupa mutant [5]. Whitten designed a machine to separate brown and black pupae of Australian sheep blowflies [6]. Smittle et al. tested a single channel machine to sort 1.7 million stable fly pupae in 24 h, but for control programmes they suggest large sorters with 38 channels to sort 65 million pupae in 24 h [7].

2. MATERIALS AND METHODS

The medflies used in the present study were from a laboratory strain, maintained on a large scale at the Entomology Section, Centro de Energia Nuclear na Agricultura, Universidade de São Paulo Piracicaba, SP. The morphological mutant 'dark puparium' (dp) [8], or 'niger' (nig) [9], was isolated from our laboratory colony in 1983 and maintained as a homozygous stock.

Medfly larvae were reared at $26 \pm 1^\circ\text{C}$ on the following artificial larval diet (in wt%): brewer's yeast, 3.69; wheat flour, 11.06; sugar, 6.45; ascorbic acid, 0.18; Nipagin, 0.22; antibiotics, 0.03; water, 17.52; acid solution (chloridric acid + benzoic acid) and sugarcane bagasse, 9.22. Adults were kept at the same temperature, $75 \pm 5\%$ relative humidity and were provided with water and a dry diet.

For translocation induction, 48 h old adult males from the laboratory strain were irradiated with 55 Gy of gamma radiation by using a ^{60}Co irradiator (185 kR/h).¹ The irradiated males were crossed with virgin females from the mutant stock and the F_1 males were individually back-crossed (one male: three females) with mutant virgin females. The F_2 progeny were reared in family groups and scored for the presence of translocations, as indicated by a pseudo-linkage between the mutant (dp or nig) and sex.

The family rearing units were similar to those of Rössler [10], but used modified Nadel's traps. Glass vials (of 500 mL capacity) were also used.

3. RESULTS AND DISCUSSION

Before starting translocation tests, the mode of inheritance of the dark, or niger, pupa phenotype was determined. Reciprocal crosses were made between virgin females and males of the mutant and laboratory stock. Some of the F_1 adults were used in reciprocal back-crosses with the mutant strain and the rest were inbred.

In the reciprocal crosses between the mutant (dp or nig) and the wild type, all pupae in the F_1 generation had the normal brown colour, indicating that dp, or nig, is a recessive trait. Table I shows the numbers of each colour observed when the F_1 progeny were either reciprocally back-crossed with mutant individuals or inbred. In each case the maternal parent is listed first. The parental cross from which the F_1 progeny came is given in parentheses, again with the maternal stock listed first. The final column gives the Chi-square values for a test of goodness of fit between the observed numbers of pupae with the mutant or wild phenotype and those expected if two alleles were sorted at random. To facilitate the crossing schemes, the mutant will be represented by the symbol dp.

In none of the four back-crosses did the observed number of pupae having two phenotypes exhibit a significant departure from the expected 1:1 ratio when hetero-

¹ 1 röntgen (R) = 2.58×10^{-4} C/kg.

TABLE I. SUMMARY OF CROSSES SHOWING THAT BLACK PUPA IS A RECESSIVE, AUTOSOMAL TRAIT

Cross $\varphi \varphi \times \sigma \sigma$	Phenotype of progeny		Ratio expected ($dp^+ : dp$)	χ^2
	Wild pupae (dp^+)	Dark pupae (dp)		
$dp \times F_1 (dp \times dp^+)$	666	657	1:1	0.06
$dp \times F_1 (dp^+ \times dp)$	576	539	1:1	1.23
$F_1 (dp \times dp^+) \times dp$	666	667	1:1	0.00
$F_1 (dp^+ \times dp) \times dp$	713	674	1:1	1.10
$F_2 (dp \times dp^+)$	2331	725	3:1	2.65
$F_2 (dp^+ \times dp)$	2213	694	3:1	4.01

zygotes are crossed with homozygous recessives. The F_2 progeny ($dp \times dp^+$) were not significantly different from the 3:1 ($dp^+ : dp$) ratio expected from such a cross, but the other F_2 progeny of the mating between dp^+ females and dp males did differ significantly from the expected 3:1 ratio ($0.05 > P > 0.01$). The adults were sexed and there was no significant departure from the normal sex ratio. Statistical analysis of the data led to the conclusion that the gene responsible for the dark/niger puparium is a recessive trait and is located on an autosome.

The irradiation tests began after the confirmation of the monofactorial inheritance of dark/niger puparium. Three hundred normal males were irradiated to induce reciprocal translocations and were mated with virgin mutant females. Two hundred and ninety-two F_2 families were examined in a search for exhibited pseudo-linkages between pupal colours and sex. Out of these 292 families, five were identified as being possible reciprocal translocation heterozygotes on the basis of complete pseudo-linkages (Table II). The rate for translocations produced was 1.7%, which is similar to the frequency for inducing translocations reported by Robinson and Van Heemert [11].

The males from the translocated lines were out-crossed with females from the mutant stock and maintained as quite large populations. Each generation line was checked for the presence of recombinants. By the third generation, deviant individuals were found in lines 121, 131 and 143. It was difficult to identify in these lines the dark/niger pupae, since some dark-brown and gray pupae were present. The nutritional conditions during the larval period might have been the cause of these shades of the pupae [12].

When the two remaining lines (44 and 213) were inbred through four generations no undesirable type was detected, but the number of flies scored in each generation was very low (on average 26). The fertility of these two translocated stocks was

TABLE II. SCORED DATA FROM TRANSLOCATION LINES OF MEDFLIES ISOLATED FROM F₂ PROGENY

Designation of strain	Wild pupae	Males	Females	Dark/niger pupae	Males	Females
Line						
44	32	4	0	40	0	22
121	14	11	0	6	0	6
131	29	23	0	27	0	17
143	5	3	0	2	0	1
213	35	8	0	20	0	6
<i>Control</i>	87	32	36	80	28	23

around 35% and the pupal viability was also very low (45%). These biological parameters suggest that more than one translocation might have occurred in these lines. Cytological examination, however, has not yet been performed.

4. CONCLUSIONS

Since it is possible to obtain a medfly strain for a genetic sexing system on the basis of pupal colour, the use of this methodology in the SMT for controlling or eradicating this pest should be considered. This translocated strain would be beneficial in reducing mass rearing costs and would be useful in future integrated pest management programmes. The females (black pupae) should be used to increase mass rearing, saving the males for control by SMT. Biological control should be carried out with a part of the pupae (females), which will then be used as the substratum for mass rearing of medfly parasites.

ACKNOWLEDGEMENTS

Thanks are due to L.A. Lopes and S. Vicino for their help during the experiments and to D. Athié for revision of the English manuscript. The research was financed partly by International Atomic Energy Agency Research Contract No. 4132/RB, partly by Financiadora e Estudos e Projetos (FINEP) No. 42.86.0735.0 and partly by the Comissão Nacional de Energia Nuclear (CNEN).

REFERENCES

- [1] KNIPLING, E.F., The Basic Principles of Insect Population Suppression and Management, Agriculture Handbook No. 512, United States Department of Agriculture, Washington, DC (1979).
- [2] CASAGRANDE, M.V., Controle biológico de mosca-do-mediterrâneo, *Ceratitis capitata* (Wied.) Através do Parasito Pupal *Muscidifurax raptor* Giralt y Sanders (Hymenoptera: Pteromalidae), Rep. 86/1899-8, Fundação de Amparo a Pesquisa e Estudos do Estado de São Paulo, Piracicaba, SP (1987).
- [3] ARTHUR, V., WALDER, J.M.M., WIENDL, F.M., Alguns aspectos biológicos de *Spalangia endius* (Walk.) criados em pupas de *Ceratitis capitata* (Wied.) em condições de laboratório, Centro de Energia Nuclear na Agricultura (in press).
- [4] WALDER, J.M.M., SEAWRIGHT, J.A., Genetic method for the separation of males and females of the house fly, *Musca domestica* (Diptera: Muscidae), J. Econ. Entomol. **78** (1985) 1030-1034.
- [5] RÖSSLER, Y., Automated sexing of *Ceratitis capitata*: The development of strains with inherited sex limited pupal colour dimorphism, Entomophaga **25** (1979) 275-281.
- [6] WHITTEN, M.J., Automated sexing of pupae and its usefulness in control by sterile insects, J. Econ. Entomol. **62** (1969) 272-273.
- [7] SMITTLE, B.J., SEAWRIGHT, J.A., BIRKY, B.K., Use of a commercial color sorter to separate sexes of stable fly (Diptera: Muscidae) pupae from a genetic sexing strain, J. Econ. Entomol. **79** (1986) 877-878.
- [8] RÖSSLER, Y., KOLTIN, Y., The genetics of the Mediterranean fruit fly, *Ceratitis capitata*: Three morphological mutations, Ann. Entomol. Soc. Am. **69** (1976) 604-608.
- [9] MANSO, F., LIFSCHITZ, E., Boll. Genet. Instituto Fitotecnica **10** (1979) 31-32.
- [10] RÖSSLER, Y., Rearing unit for single-pair or small cultures of the Mediterranean fruit fly (Diptera: Tephritidae), J. Econ. Entomol. **77** (1984) 556-557.
- [11] ROBINSON, A.S., VAN HEEMERT, C., *Ceratitis capitata* — A suitable case for genetic sexing, Genetics **58** (1982) 229-237.
- [12] CAVICCHI, S., BELLETTINI, S., Genetic polymorphism of puparium colour in *Ceratitis capitata* (Wied.), Monit. Zool. **7** (1973) 135-149.

ISOLATION AND MASS REARING OF A PUPAL GENETIC SEXING STRAIN OF THE MEDITERRANEAN FRUIT FLY, *Ceratitidis capitata* (Wied.)*

E. BUSCH-PETERSEN, J. RIFFEL, A. PYREK, A. KAFU
FAO/IAEA Entomology Unit,
IAEA Seibersdorf Laboratory,
Vienna

Abstract

ISOLATION AND MASS REARING OF A PUPAL GENETIC SEXING STRAIN OF THE MEDITERRANEAN FRUIT FLY, *Ceratitidis capitata* (Wied.).

The induction and isolation of a multiple translocation strain in the Mediterranean fruit fly is described. Cytological analysis of this strain, T30C, showed the presence of a reciprocal autosomal translocation. In addition, a Y-autosome translocation, not involved in the reciprocal A-A translocation, was observed in meiotic chromosome preparations on a single occasion. Male viability of T30C was reduced both in the homozygous and in the heterozygous configurations when measured as egg hatch and as adult emergence, whereas a significant reduction in female viability was observed only in the egg hatch of the homozygous configuration, thus indicating the possible presence of chromosomal aberrations in male flies that are not present in female flies. T30C was back-crossed with the homozygous *w^p* mutant, resulting in the genetic sexing strain T:Y(*w^p*⁺)30C, in which males emerge consistently from brown puparia and females from white. Laboratory scale rearing for 24 generations provided no indication of instability in this strain. Mass rearing for ten generations resulted in the presence of 2.3% fertile females among the brown pupae, the first such females being observed in generation 4. A very low level of males emerging from white puparia was observed in almost every generation from the parental generation onwards. However, this level did not appear to increase. The possible cause of the observed low level of instability in T:Y(*w^p*⁺)30C when mass reared is discussed, and it is concluded that this was caused by the accidental introduction of foreign gene pools. The overall viability of the mass reared T:Y(*w^p*⁺)30C did not differ significantly from that of the standard mass reared 'Sohag' strain. The stability and viability of T:Y(*w^p*⁺)30C thus renders this strain suitable for inclusion in sterile insect technique (SIT) programmes dependent upon the release of only the male sex.

1. INTRODUCTION

The Mediterranean fruit fly (medfly), *Ceratitidis capitata* (Wied.), is a very destructive pest of more than one hundred agriculturally important fruit crops throughout the tropical and subtropical regions of the world [1]. Because this pest can be efficiently controlled or eradicated by the use of integrated pest management

* This work forms part of a joint FAO/IAEA research programme on the development of genetic sexing mechanisms in the Mediterranean fruit fly.

procedures involving the sterile insect technique (SIT) [2–5], much research is presently being focused on the development of genetic sex separation methods for this species [6].

Genetic sexing mechanisms have been developed in at least 15 species of insects [7], including the medfly. Genetic sexing in the medfly was pioneered by Rössler [8], who succeeded in linking the wild type allele of the black pupae (*bp*) gene onto the Y-chromosome. This was later followed by the development of a mechanism based on a brown/white pupal colour dimorphism [9] and, more recently, by one based on purine sensitivity [10]. However, all of these have drawbacks when considered in a mass rearing context. The purine sensitivity mechanism is hampered by the high cost of purine and the relative scarcity of purine on the world market. In addition, the egg to adult viability of the genetically sexed purine strain is only 17.2% of that of its wild type counterpart. The pupal colour strains are rather more promising, although they rely on the sexes being separated at the pupal stage, and therefore do not provide any saving in the actual cost of larval rearing.

A sound justification for the incorporation of genetic sexing mechanisms into SIT pest management programmes should by no means be restricted solely to a concern for reducing the cost of larval rearing. Although a reduction in these costs will not be provided by a strain based on pupal colour dimorphisms, additional savings may be attained by the necessity to store, irradiate, transport and release only the male portion of the mass reared insects. In addition, evidence from field cages has indicated that the release of only sterile males will increase the efficiency of the SIT by 50–100% owing to an elimination of the non-random mating commonly observed when releasing both sexes [11]. This increase in efficiency will effectively lead to a substantial reduction in the cost of SIT programmes.

A major consideration in contemplating the use of SIT for medfly control is the potential damage caused to the host commodities by the sterile females during the SIT release phase. Although these females are sterile and produce no offspring, they still attempt to oviposit in available host fruits, thus creating oviposition punctures which are prone to bacterial and fungal infections. Even without such infections the mere presence of oviposition punctures is often sufficient to drastically reduce the market value of such fruit and to render it unsuitable for export. For this reason, large scale employment of SIT is rarely considered by countries relying on fruit production for export. The employment of genetic sexing mechanisms prior to release would effectively eliminate this restriction on the use of SIT, and would make this means of pest control highly attractive to a number of the major fruit exporting countries. This, in turn, would create added interest, confidence and acceptance of SIT in the less affluent regions of the world. Not until methods become available to eliminate females from release consignments will SIT gain widespread acceptance for medfly control.

Considering the above arguments, it was decided to further investigate the use of existing medfly mutants as potential 'sexing' mechanisms. The standard T:Y(*w^p*⁺)101 brown/white sexing strain has previously shown itself to be prone to

recombination during mass rearing, resulting in rapid breakdown of the sex separation mechanism [12]. Here, we report on the induction and isolation of a medfly genetic sexing strain also based on a brown male/white female pupal colour dimorphism, as well as on the stability and viability of this strain under mass rearing conditions.

2. MATERIALS AND METHODS

The strains employed were:

- dc*: double chaetae [13], recessive, autosomal;
- ap*: apricot eye [13], recessive, autosomal;
- ap dc*: double mutant strain with two linked markers;
- wp*: white pupae [14], recessive, autosomal;
- 'Sohag': standard mass reared wild-type strain [15].

The T30C strain was induced and isolated as part of an experiment aimed primarily at producing chromosomal aberrations which would reduce or eliminate recombination in females between the linked *ap* and *dc* alleles [16]. Homozygous *dc/dc* males were irradiated one day after adult emergence with 50 Gy of gamma irradiation and mass mated one day later with virgin *ap/ap* females. The F₁ females were crossed in single pairs with homozygous, double mutant males and F₂ families showing absence of female recombination were isolated and further inbred in single pairs. This single pair inbreeding was continued until three successive generations had been confirmed as breeding true.

All promising lines were carefully monitored cytologically throughout the breeding programme up to, and including, the establishment of homozygous lines. At this stage, a final check was carried out by crossing each homozygous line with *ap*, so that the structurally heterozygous condition could be observed in their progeny. All meiotic studies were conducted on the developing testes of male pupae, as described by Busch-Petersen and Southern [16]. These preparations also included cells at various stages of mitosis. In addition, female mitosis was occasionally examined in ovaries by the same technique.

The viability of the T30C strain was assessed in both the homozygous and heterozygous conditions. Viability of the homozygote was determined by crossing homozygous males and females with wild type females and males, respectively, while that of the heterozygote was measured by back-crossing the F₁ flies with the wild type strain. All four reciprocal back-crosses were tested as described by Busch-Petersen et al. [17] and egg hatch and the resultant adult sex ratio were determined.

T30C males were crossed and back-crossed with virgin homozygous *wp* females in order to develop the T:Y(*wp*⁺)30C strain, in which males emerge from brown puparia and females from white. Continuous maintenance of the strain was subsequently performed through standard inbreeding.

Mass rearing of the T:Y(*w^p*⁺)30C strain was initiated in January 1987 and is still continuing. Mass rearing was performed as described by Hooper [15], except that larvae were kept at 28°C and 80–90% relative humidity (RH) throughout their development. One adult cage (2 m × 2 m × 0.2 m wide) was set up for each generation with approximately 270 000 pupae and eggs were collected for 5–12 successive days. Generations were kept non-overlapping in order to permit separate recording and analysis of data for each generation. The frequency of contaminant phenotypes and the viability of the mass reared T:Y(*w^p*⁺)30C strain was assessed as described by Busch-Petersen and Kafu [18].

Egg hatch, pupal production and adult emergence were recorded during three generations in the standard mass reared Sohag strain. Similar data were recorded at the same time from generations 5 to 7 in T:Y(*w^p*⁺)30C, thus allowing a comparison of the viability of these two strains.

3. RESULTS

No detailed data are presented. Instead, the overall results are described and discussed.

Several positive lines were obtained in the experiment aimed at isolating factors that suppress female recombination [16]. However, whereas all other lines were found to be breeding true after three to four generations of selection, line T30C required 13 generations, involving a total of 1185 selected single pair families. No *ap* phenotype was observed in the F₁ when out-crossing this line with the homozygous *ap* strain, thus suggesting that the line was homozygous for the originally irradiated *dc* chromosome.

During cytological analysis of T30C, the presence of a Y-linked translocation in addition to, and not involved in, the reciprocal autosomal translocation was observed on a single occasion [16]. However, despite a concerted effort aimed at analysing this aberration complex, the Y-linked translocation was never observed in subsequent cytological preparations of this strain.

The viability of both sexes of strain T30C was calculated in terms of both egg hatch and adult emergence from hatched eggs. Significant differences were consistently observed between the viabilities of reciprocal crosses in the egg hatches of the homozygous and heterozygous configurations. When measured in terms of adult emergence, the viability was consistently higher in the female carrier. Female viability was significantly different from that of the control only in the homozygous configuration when measured in terms of egg hatch, whereas male viability was always significantly reduced. The persistently lower viability of males suggested the possible presence of aberrations in this sex not present in the females.

Out-crossing and back-crossing of T30C females with homozygous *w^p* females resulted in the production of F₂ offspring where all the males emerged from brown

puparia and all females from white. This strain, named T:Y(*wp*⁺)30C, has shown no indication of breakdown during 24 generations of laboratory rearing.

Mass rearing of T:Y(*wp*⁺)30C has been performed for ten generations. A small number of males emerging from white pupae was observed from the parental generation onwards. However, only in generations 5, 7, 8 and 10 were a proportion of these found to be fertile. Only 35% of the contaminant males found throughout the ten generations were fertile. Females emerging from brown pupae were first observed in generation 3; however, these were all infertile. The number of observed, fertile females increased slowly from generation 4 onwards to reach 2.3% of the brown pupae screened in generation 10. All females emerging from brown pupae were found to be heterozygous *wp*⁺/*wp*, except in the last three generations when one homozygous *wp*⁺/*wp*⁺ female was found in each generation. A total of 44% of the females emerging from brown pupae throughout the experiment were fertile.

The mean viability of the T:Y(*wp*⁺)30C strain was measured in terms of egg hatch, pupal production from hatched eggs and adult emergence from brown pupae. Corresponding data were obtained during the same period from the standard mass reared Sohag strain. Although the two strains differed significantly in the individual parameters, the overall viability of T:Y(*wp*⁺)30C was not significantly different from that of the Sohag strain.

4. DISCUSSION

A consistent reduction was observed in male viability both in the homozygous and heterozygous configurations of T30C, whereas such a reduction was observed in the female homozygote only when measured in terms of egg hatch. As T30C is known to contain a reciprocal autosomal translocation, a reduction in viability may be expected from the creation of unbalanced gametes when recombination takes place in the interstitial segment between the centromere and the breakpoint in the translocation heterozygote, and is followed by alternate segregation. However, although the heterozygous viability was reduced in both sexes, it was significant only in the males. Busch-Petersen and Southern [16], in explaining the high degree of recombination suppression observed in a series of reciprocal, autosomal translocation lines, suggested that recombination suppression may be caused not only by the production of aneuploid gametes, but also by the interference by the translocation heterozygote with the initiation or maintenance of cross-over synapsis. Such interference would have little effect on viability and may thus explain the relatively high viability observed in T30C females. The Y-linked translocation additionally present in T30C males is likely to have resulted in the significantly lower viability of this sex.

The instability of genetic sexing strains under mass rearing conditions is not an uncommon feature and has been observed in varying degrees in mosquitoes [19-22], house flies [23], stable flies [24], the Australian sheep blowfly [25] and the medfly [12]. Such instability may arise from a number of causes. In the medfly, where sex

is determined by an X-Y chromosome complement [26,27], recombination occurring in the region between the 'sexing' allele and the translocation breakpoint will result in the transfer of this allele onto the autosome. The sexing allele will now be inherited independently of sex and cause the genetic sexing mechanism to break down. The rate of this breakdown will initially depend upon the frequency of recombination within the above region, which will itself be dependent to a large extent upon the distance between the sexing allele and the translocation breakpoint.

The fact that the Y-linked translocation in T30C was observed in cytological preparations only on a single occasion suggested that the autosomal segment, which had been translocated onto the Y-chromosome, was so small that it was unable to initiate and maintain the formation of the pairing cross characteristically observed during the first meiotic prophase in translocation heterozygotes. It was therefore reasonable to assume that as the wp^+ allele was invariably inherited through the male sex in T:Y(wp^+)30C, the wp^+ allele was actually located within the Y-translocated autosomal segment, or, if located in the interstitial segment between the translocation breakpoint and the centromere, then very close indeed to the breakpoint. This assumption is further reinforced by the observed high viability in T:Y(wp^+)30C. This high viability points towards two conclusions. First, as no pairing cross is present during cell divisions, the translocated autosome and its non-translocated pairing partner will pair and recombine normally and will segregate at random. Thus, as segregation of the translocated chromosomes occurs at random without causing any appreciable reduction in the level of fertility, it appears that the segmentally aneuploid gametes, necessarily arising from such segregation, are by and large fully viable. Second, as wp^+ is invariably inherited through the male sex, the sexing allele is unlikely to be located on the autosome, but must necessarily be linked to the Y-chromosome.

According to Hooper et al. [12], a recombination frequency of at least 0.4% would be required to account for the 2.3% fertile females observed among the brown pupae in generation 10. However, as any recombination frequency above 0.0025% should also have been observed during a laboratory scale experiment that was run in parallel, where no such recombination was observed, recombination itself cannot account for the observed instability of T:Y(wp^+)30C. In addition, the number of observed recombinant males should also have increased, which did not happen. Recombination, therefore, does not appear to be responsible for the instability observed in this strain.

Another genetic feature, which will lead to the breakdown of genetic sexing mechanisms, is the innate ability of the cell to repair certain kinds of damage, either through a reversion of the translocation to the normal karyotype, or through a reverse mutation of the sexing allele. The effect of such repair on the stability of genetic sexing mechanisms will again depend initially upon the frequency with which this repair occurs.

Contamination of genetic sexing strains, arising from the introduction of foreign gene pools, will also result in strain breakdown. However, although the frequency

of such contamination does influence, to some extent, the rate of breakdown, the sex of the introduced contaminant fly and, in the case of a contaminant female, the reproductive status of this female, plays a much larger role. Hooper et al. [12] showed in computer simulations that contamination by virgin females would result in an initial rapid breakdown which reached a plateau within a few generations. This plateau, however, was invariably so low that virgin females alone could hardly influence the stability under mass rearing conditions. Females from brown pupae were approximately twice as common as males from white pupae. Contamination by males would result initially in a low rate of breakdown, but would later progress at an exponential rate, eventually achieving the complete disintegration of the sexing mechanism [12]. In the case of a male contamination frequency at or below 0.01%, males emerging from white pupae would reach almost 40% before females from brown pupae would start to appear.

A low frequency of female contamination thus appears to provide the best explanation for the results observed here. The absence of the plateau, predicted by Hooper et al. [12], is very likely due to the reduced viability of the *w^p* allele. Such a reduction in viability would have the effect of raising, or, most likely, eliminating this plateau.

The viability of the egg and pupal stages of T:Y(*w^p*⁺)30C under mass rearing conditions were both significantly below that of the standard Sohag strain. However, a significantly higher pupal production rate rendered the overall viability of this strain very similar to that of Sohag. Thus, the strain is acceptable for mass rearing and, considering its stability and probable lack of male recombination through 11 generations of mass rearing, shows excellent potential for utilization in SIT programmes relying and depending upon the release of genetically sexed males.

ACKNOWLEDGEMENTS

D.I. Southern, Department of Cell and Structural Biology, School of Biological Sciences, University of Manchester, Manchester, United Kingdom, provided the analysis of the meiotic and mitotic chromosome preparations. His assistance is gratefully appreciated. Our thanks are due also to D.A. Lindquist and R.E. Gingrich of the Joint FAO/IAEA Division for Isotope and Radiation Applications of Atomic Energy for Food and Agricultural Development for their continuous and enthusiastic support of this programme. The technical assistance of E. Schorn, A. Hafner and H. Baumgartner, and the typing of this manuscript by E. Pereira, is gratefully acknowledged.

REFERENCES

- [1] TEJADA, L.O., Estudio sobre las hospederas potenciales de la mosca del Mediterraneo, *Ceratitis capitata* Wied., Secretaría de Agricultura y Recursos Hidráulicos, Dirección General de Sanidad Vegetal, Mexico (1980) 95.

- [2] ORTIZ, G., et al., "Mediterranean fruit fly (*Ceratitidis capitata*): Status of the eradication programme in Southern Mexico and Guatemala", Fruit Flies (Proc. 2nd Int. Symp. Colymbari, Crete, 1986) (ECONOMOPOULOS, A.P., Ed.), Elsevier, Amsterdam (1987) 523-532.
- [3] FISHER, K.T., Eradicating fruit fly from Carnarvon, J. Agric. 26 (1985) 33-39.
- [4] HENDRICH, J., ORTIZ, G., LIEDO, P., SCHWARZ, A., "Six years of successful medfly program in Mexico and Guatemala", Fruit Flies of Economic Importance (Proc. Int. Symp. Athens, 1982) (CAVALLORO, R., Ed.), A.A. Balkema, Rotterdam (1983) 353-365.
- [5] CUNNINGHAM, R.T., et al., Eradication of medfly by sterile-male release, Citograph 65 (1980) 63-69.
- [6] ECONOMOPOULOS, A.P. (Ed.), Fruit Flies (Proc. 2nd Int. Symp. Colymbari, Crete, 1986), Elsevier, Amsterdam (1987).
- [7] BUSCH-PETERSEN, E., "Genetic sex separation in sterile insect technique pest management programmes, with special reference to the medfly, *Ceratitidis capitata* (Wied.)", Fruit Flies of Economic Importance (Proc. Int. Symp. Rome, 1987) (CAVALLORO, R., Ed.), A.A. Balkema, Rotterdam (in press).
- [8] RÖSSLER, Y., Automated sexing of *Ceratitidis capitata* (Diptera:Tephritidae): The development of strains with inherited, sex-limited pupal color dimorphism, Entomophaga 24 (1979) 411-416.
- [9] ROBINSON, A.S., VAN HEEMERT, C., *Ceratitidis capitata* — A suitable case for genetic sexing, Genetica 58 (1982) 229-237.
- [10] SAUL, S.H., Genetic sexing in the Mediterranean fruit fly, *Ceratitidis capitata* (Wiedemann) (Diptera:Tephritidae): Conditional lethal translocations that preferentially eliminate females, Ann. Entomol. Soc. Am. 77 (1984) 280-283.
- [11] ROBINSON, A.S., CIRIO, U., HOOPER, G.H.S., CAPPARELLA, M., Field cage studies with a genetic sexing strain in the Mediterranean fruit fly, *Ceratitidis capitata*, Entomol. Exp. Appl. 41 (1986) 231-235.
- [12] HOOPER, G.H.S., ROBINSON, A.S., MARCHAND, R.P., "Behaviour of a genetic sexing strain of Mediterranean fruit fly, *Ceratitidis capitata*, during large scale rearing", Fruit Flies (Proc. 2nd Int. Symp. Colymbari, Crete, 1986) (ECONOMOPOULOS, A.P., Ed.), Elsevier, Amsterdam (1987) 349-362.
- [13] RÖSSLER, Y., KOLTIN, Y., The genetics of the Mediterranean fruit fly, *Ceratitidis capitata*: Three morphological mutations, Ann. Entomol. Soc. Am. 69 (1976) 604-608.
- [14] RÖSSLER, Y., The genetics of the Mediterranean fruit fly, *Ceratitidis capitata*: A "white pupae" mutant, Ann. Entomol. Soc. Am. 72 (1979) 583-585.
- [15] HOOPER, G.H.S., Application of quality control procedures to large scale rearing of the Mediterranean fruit fly, Entomol. Exp. Appl. 44 (1987) 161-167.
- [16] BUSCH-PETERSEN, E., SOUTHERN, D.I., Induced suppression of genetic recombination in females of the Mediterranean fruit fly, *Ceratitidis capitata* (Wied.), by translocation heterozygosity, Genetica 72 (1987) 161-169.
- [17] BUSCH-PETERSEN, E., PYREK, A., RIPPPEL, J., Viability and behaviour of translocations that suppress female recombination in the Mediterranean fruit fly, *Ceratitidis capitata* (Wied.), Theor. Appl. Genet. 74 (1987) 38-41.
- [18] BUSCH-PETERSEN, E., KAFU, A., Stability of two mass reared genetic sexing strains of the Mediterranean fruit fly, *Ceratitidis capitata* (Wiedemann) (Diptera:Tephritidae), based on pupal colour dimorphisms (in press).
- [19] CURTIS, C.F., AKIYAMA, J., DAVIDSON, G., A genetic sexing system in *Anopheles gambiae* species A, Mutat. Res. 36 (1976) 492-498.
- [20] BAKER, R.H., SAKAI, R.K., RAANA, K., Genetic sexing for a mosquito sterile-male release, J. Hered. 72 (1981) 216-218.
- [21] SEAWRIGHT, J.A., KAISER, P.E., DAME, D.A., LOFGREN, C.S., Genetic method for the preferential elimination of females of *Anopheles albimanus*, Science 200 (1978) 1303-1304.

- [22] LINES, J.D., CURTIS, C.F., Genetic sexing systems in *Anopheles arabiensis* Patton (Diptera: Culicidae), J. Econ. Entomol. **78** (1985) 848-851.
- [23] WALDER, J.M.M., SEAWRIGHT, J.A., Genetic method for the separation of males and females of the house fly, *Musca domestica* (Diptera: Muscidae), J. Econ. Entomol. **78** (1985) 1030-1034.
- [24] SEAWRIGHT, J.A., BIRKY, B.K., SMITTLE, B.J., Use of a genetic technique for separating the sexes of the stable fly (Diptera: Muscidae), J. Econ. Entomol. **79** (1986) 1413-1417.
- [25] FOSTER, G.G., MADDERN, R.H., MILLS, A.T., Genetic instability in mass-rearing colonies of a sex-linked translocation strain of *Lucilia cuprina* (Wiedemann) (Diptera: Calliphoridae) during a field trial of genetic control, Theor. Appl. Genet. **58** (1980) 169-175.
- [26] RADU, M., RÖSSLER, Y., KOLTIN, Y., The chromosome of the Mediterranean fruit fly, *Ceratitis capitata* (Wied.): Karyotype and chromosomal organization, Cytologia **40** (1975) 823-828.
- [27] SOUTHERN, D.I., Cytogenetic observations in *Ceratitis capitata*, Experientia **32** (1976) 20-22.

UPDATING OF THE GENETICS OF *Ceratitis capitata* (Wied.)

A.R. MALACRIDA, G. GASPERI, L. BARUFFI,
G.F. BISCALDI, R. MILANI
Department of Animal Biology,
University of Pavia,
Pavia, Italy

Abstract

UPDATING OF THE GENETICS OF *Ceratitis capitata* (Wied.).

Twenty-four markers are currently distributed over four linkage groups. They include structural genes coding for enzyme functions, sex ratio distorting factors and developmental and sex specific genes. The studies on alcohol dehydrogenase (ADH) in the Mediterranean fruit fly (medfly), *Ceratitis capitata* (Wied.), revealed a system different to that existing in *Drosophila melanogaster*. The presence of two *Adh* genes in the medfly makes the development of a genetic sexing system, as developed in *D. melanogaster*, more complex. In the work on xanthine dehydrogenase (XDH), priority has been given to the definition of the properties of the structural gene *Xdh* in order to provide indirect critical evidence for the assumption that *ry* genes of the medfly and *D. melanogaster* are homologous. In gravid females and in eggs, a β -specific naphthyl acetate esterase is present. The limitation of gene products to gravid females and to eggs suggests that the β -*Esr* locus might have potential for genetic manipulation. Four major larval serum proteins (LSP) are released in the haemolymphs of 3-4 d old larvae; they reach maximal levels prior to pupation and then decline gradually according to a precise temporal pattern. These proteins are coded by four independent genes. Two proteins showing sex, developmental stage and tissue specificity have been recognized in the fat body of adult males.

1. INTRODUCTION

The progress in work on the Mediterranean fruit fly (medfly), *Ceratitis capitata* (Wied.), has enabled us to extend and integrate the information already available on specific points of the genetics of this pest insect [1, 2] and to deal with new lines. The research subjects were:

- Improvement of the linkage maps,
- Genetic and biochemical analyses of alcohol dehydrogenase (ADH) and xanthine dehydrogenase (XDH) systems,
- Identification of developmental and sex specific proteins.

2. IMPROVEMENT OF THE LINKAGE MAPS

Twenty-four markers are currently distributed over four linkage groups (Table I). Two of these also include one morphological marker. The *Xdh* structural

TABLE I. AVAILABLE EVIDENCE FOR MERGING DATA ON LINKAGES DERIVED FROM THE USE OF BIOCHEMICAL MARKERS AND VISIBLE MUTANTS. FOR VISIBLE MUTANTS THE SYSTEM OF LABELLING OF LINKAGE GROUPS PROPOSED BY SAUL AND RÖSSLER HAS BEEN ADOPTED [3]. PLUS SIGNS, DASHES AND QUESTION MARKS INDICATE, RESPECTIVELY, LINKAGES, FREE REASSORTMENTS AND COMBINATIONS NOT YET TESTED

	A (ap)	B (w)	C (dp)	D (ry)	E (bro)
<i>Hk₂, Est₁, Sd₁, Est₂, Pgi, β-Est</i>	+	-	-	-	-
<i>Zw, Pgd, Fh, Had, Lsp_{III}</i>	-	+	-	-	-
<i>Mpi, Est₆, Adh₁, Aox, Xdh, Mdh₂, Lsp₁</i>	-	-	-	?	?
<i>Idh, Pgm, Sd₂, Got₁, Gox, Lsp_{II}</i>	-	-	-	?	?

locus for the enzyme XDH has recently been allocated to the linkage group *Mpi...Adh₁* (at 28 ± 0.06 from the *Mpi* locus). With respect to the medfly mutant *rosy* (*ry*), it is necessary to determine if this gene codes for XDH, as was previously supposed [4]. The *β-Est* locus is a sex and developmental specific gene which belongs to the linkage group *ap...Pgi*. This locus codes for a *β*-specific esterase.

Lsp_I, *Lsp_{II}* and *Lsp_{III}* are three other developmental genes which belong, in order, to the linkage groups *Mpi...Adh₁*, *Idh...Got₁* and *w...Fh* [5]. *Lsp* genes are larval specific; their expression is limited to larval stages, probably by specific regulating mechanisms. The dispersion of three *Lsp* family genes of *C. capitata* over different chromosomes possibly indicates a significant level of similarity with *Drosophila* [6].

Sd₂ is a sex ratio distorter gene having distorting effects similar to those of *Sd₁* [1]. *Sd₂* belongs to the *Idh...Lsp_{II}* linkage group. Cross-over rates of 0.67 ± 0.006 and 38.5 ± 0.03 have been found in the intervals *Sd₂-Got₁* and *Sd₂-Idh*, respectively. The presence of *Sd₂* does not affect the cross-over rates in the interval *Idh-Got₁*.

3. GENETIC AND BIOCHEMICAL ANALYSES OF ADH AND XDH SYSTEMS

Studies on ADH and XDH in the medfly have been carried out within the framework of the development of conditional lethal systems on the basis of positive results obtained in *D. melanogaster* [7, 8].

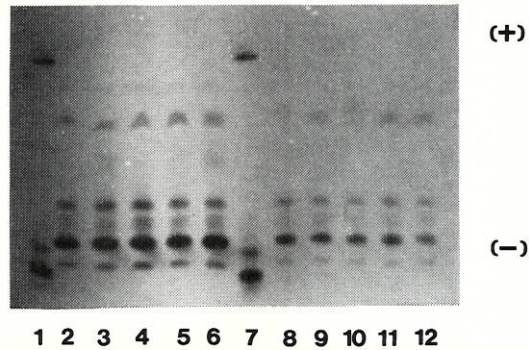

FIG. 1. Isoelectrofocusing pattern for ADH of *C. capitata* females (lanes 1 and 7) and *Capparimyia savastanoi* Mart. (females: lanes 2-6; males: lanes 8-12).

3.1. Alcohol dehydrogenase

The enzyme ADH of *C. capitata* is a system different to that existing in *D. melanogaster* [2]. In the medfly, two independent genes (*Adh*₁ and *Adh*₂) code for two well differentiated isozymes, while the ADH function of *D. melanogaster* is controlled at a single locus [9].

The analyses of the isoelectric point (pI), titration curve shapes, substrate specificity of the two ADH forms of medfly and that of *Drosophila* revealed a different protein structure for these three enzymes [10]. In addition, the two *Adh* loci of *C. capitata* are not co-ordinately expressed during development and show clear-cut tissue expression. ADH-2 is mainly present in fat body, while ADH-1 is limited to musculature. The single *Adh* gene of *D. melanogaster*, which is controlled during development by the alternate use of its two promoters [11], expresses one ADH protein which is primarily expressed in the fat body [12].

The unique features of the ADH system of *C. capitata* make the development of a genetic sexing system, as developed in *D. melanogaster*, more complex. On the other hand, the different ADH systems of *C. capitata* and *D. melanogaster* may be suited to the distinct life requirements of the larvae and adults of the two species. Two ADH genes were recognized in other Tephritidae flies, such as *Rhagoletis* [13] and *Anastrepha* [14] of the same *Trypetini* 'tribe' of *C. capitata*. A similar ADH system with two loci is also present in another species of this tribe, *Capparimyia savastanoi* Mart. [15] (Fig. 1). It is probable that the presence of two *Adh* genes is a widespread condition among the members of the *Trypetini* tribe. A single *Adh* gene has been ascertained in *Dacus oleae* [16], of the *Dacini* tribe (Tephritidae family).

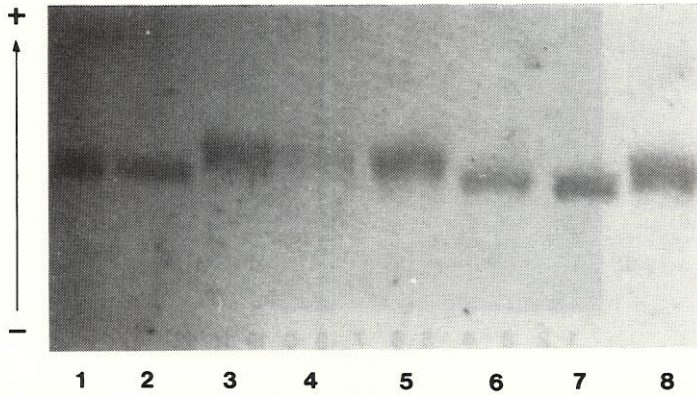

FIG. 2. Electrophoretic patterns for XDH obtained by third instar larvae of *C. capitata*. Lanes 1, 2, 6, 7: homozygous XDH-B phenotypes. Lanes 3, 4, 5, 8: heterozygous XDH-AB phenotypes.

3.2. Xanthine dehydrogenase

In the work on XDH, priority has been given to the identification of the structural gene *Xdh* in order to provide indirect evidence for the assumption that the *ry* genes of the medfly and *D. melanogaster* are homologous [4].

Xdh is the locus which in the case of the medfly affects the electrophoretic mobility of several XDH allozymes (Fig. 2). However, the fact that *Xdh* is the structural gene for XDH does not exclude the possibility that, also in medfly, control elements play other roles in the synthesis and activity of this enzyme. In *D. melanogaster*, *ry* is the structural gene for XDH, but the activity of XDH is also affected by mutations at other loci [17]. In medfly, as in *D. melanogaster*, the XDH developmental profile shows a peak at the late third instar larvae. These data suggest that *Xdh* and *ry* genes may be co-ordinately regulated during the life cycles of these two species.

4. DEVELOPMENTAL AND SEX SPECIFIC PROTEINS

The study of proteins limited to a specific developmental stage or to one sex leads to the recognition of developmental and/or sex specific genes. Such gene categories deserve special attention for their potential in the development of genetic sexing strategies [18].

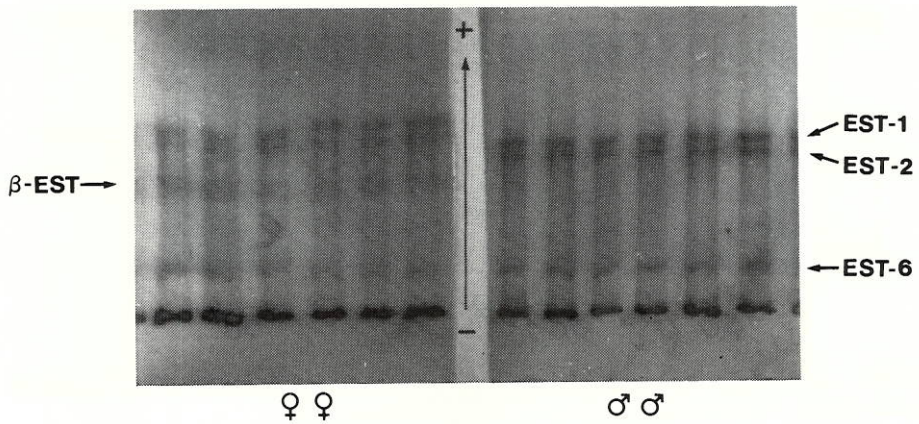

FIG. 3. Zymograms of esterase (EST) system provided by single 10 d old flies of *C. capitata*. The β -esterase is present only in gravid females. Its two banded pattern is indicative of a heterozygous condition.

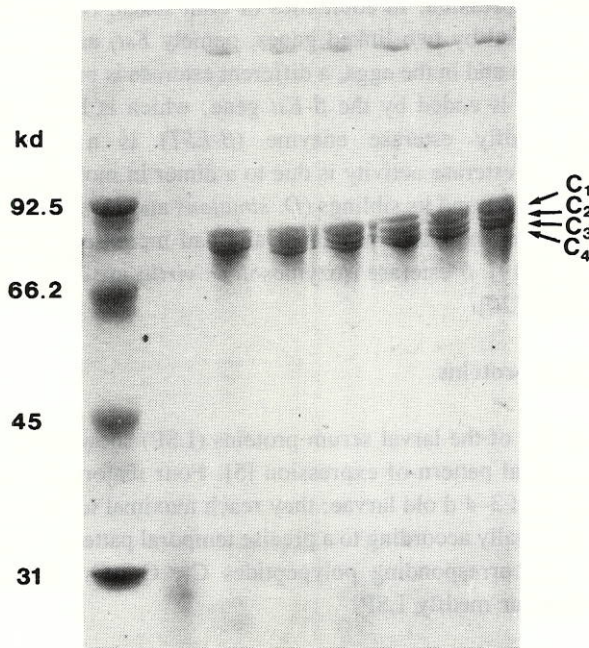

FIG. 4. Polyacrylamide gel electrophoresis, in the presence of sodium dodecyl sulphate, of haemolymph proteins of *C. capitata*. The four polypeptides, C_1 , C_2 , C_3 and C_4 (ceratitins), show molecular weight values of 83, 82, 79 and 77 kilodalton, respectively. (1 dalton \equiv 1 unified atomic mass unit $\approx 1.66 \times 10^{-27}$ kg.)

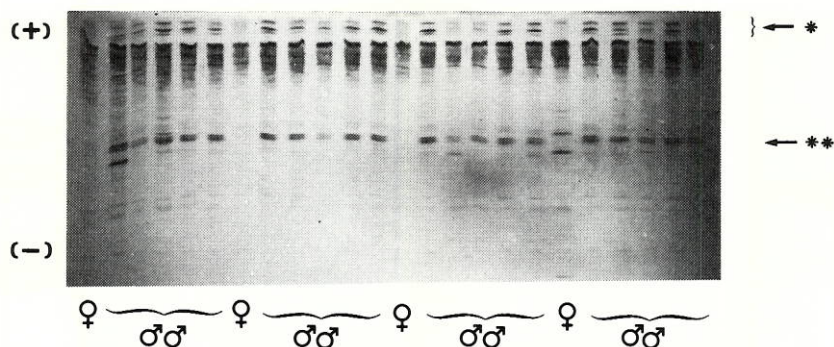

FIG. 5. Isoelectrofocusing pattern (pH range 4–6.5) showing sex specific proteins of adult specimens of *C. capitata*. *: male specific proteins; **: male fat body proteins.

4.1. Sex and developmental specific esterases

The esterase system of *C. capitata* includes genes showing developmental and/or sex specific expression. In adult flies of both sexes, two cholinesterases are present. They are coded by two linked genes, namely *Est*₁ and *Est*₂ [1].

In gravid females and in the eggs, a different esterase is present, which requires β -naphthyl acetate. It is coded by the β -*Est* gene, which is linked to the *Est*₁ and *Est*₂ loci. This medfly esterase enzyme (β -*EST*) is a monomeric protein (Fig. 3). The ' β -like' esterase activity is due to a dimer in most *Drosophila* species. *Drosophila melanogaster* and its siblings (*D. simulans* and *D. mauritania*) are exceptions in which this enzyme was a monomer and had increased activity in the male reproductive system [19]. β -esterase isozymes in *D. virilis* are characterized by tissue and stage specificity [20].

4.2. Larval serum proteins

The gene family of the larval serum proteins (LSP) shows in *C. capitata* a coordinate developmental pattern of expression [5]. Four major proteins are released in the haemolymphs of 3–4 d old larvae; they reach maximal levels prior to pupation and then decline gradually according to a precise temporal pattern. Four co-expressed genes code for the corresponding polypeptides C₁, C₂, C₃, C₄ (Fig. 4), which oligomerize to the four medfly LSP.

4.3. Sex specific proteins in the male

Two proteins showing sex, developmental stage and tissue specificity have been recognized in the fat body of adult males. They are represented by two close bands

in the isoelectrofocusing patterns shown in Fig. 5. In the same figure some other male specific proteins appear which are around pH4.

REFERENCES

- [1] MALACRIDA, A.R., GASPERI, G., MILANI, R., in Fruit Flies (Proc. 2nd Int. Symp. Colymbari, Crete, 1986) (ECONOMOPOULOS, A.P., Ed.), Elsevier, Amsterdam (1987) 169.
- [2] GASPERI, G., MALACRIDA, A.R., MILANI, R., *ibid.*, p. 149.
- [3] SAUL, S.H., RÖSSLER, Y. *Ann. Entomol. Soc. Am.* **77** (1984) 323-327.
- [4] SAUL, S.H., *Ann. Entomol. Soc. Am.* **75** (1982) 480.
- [5] MALACRIDA, A.R., GASPERI, G., BARUFFI, L., BISCALDI, G.F., MILANI, R., in Fruit Flies of Economic Importance (Proc. Int. Symp. Rome, 1987) (CAVALLORO, R., Ed.), A.A. Balkema, Rotterdam (in press).
- [6] ROBERTS, D.B., BROCK, H.W., *Experientia* **37** (1981) 103.
- [7] ROBINSON, A.S., *Annu. Rev. Genet.* **17** (1983) 191.
- [8] SAUL, S.H., in Fruit Flies (Proc. 2nd Int. Symp. Colymbari, Crete, 1986) (ECONOMOPOULOS, A.P., Ed.), Elsevier, Amsterdam (1987) 191.
- [9] ASHBURNER, M., AARON, C.S., TSUBOTA, S., *Genetics* **102** (1982) 421.
- [10] GASPERI, G., MALACRIDA, A.R., MILANI, R., ROBINSON, A.S., *Atti Assoc. Genet. Ital.* **33** (1987) 155.
- [11] BENYAJATI, C., SPOEREL, N., HAYMERLE, H., ASHBURNER, M., *Cell* **33** (1983) 125.
- [12] URSPRUNG, H., SOFER, W.H., BURROUGHS, N., *Wilhelm Roux's Arch. Dev. Biol.* **164** (1970) 201.
- [13] BERLOCHER, S.H., BUSH, G.L., *Syst. Zool.* **31** (1982) 136.
- [14] MATIOLI, S.R., MORGANTE, J.S., MALAVASI, Q., *Biochem. Genet.* **24** (1986) 24.
- [15] GRANDI, G., in *Introduzione allo Studio dell'Entomologia*, Edizioni Agricole-Bologna, Vol. 2 (1951) 431.
- [16] ZOUROS, E., LOUKAS, M., ECONOMOPOULOS, A.P., MAZOMENOS, B., *Heredity* **48** (1982) 169.
- [17] O'BRIEN, S.J., in *Genetics and Biology of Drosophila* (ASHBURNER, M., WRIGHT, I.R.F., Eds), Vol. 2a, Academic Press, New York (1978) 490.
- [18] INTERNATIONAL ATOMIC ENERGY AGENCY, Application of Genetic Engineering of Recombinant DNA Technology in the Development of a Genetic Sexing Mechanism for the Mediterranean Fruit Fly, *Ceratitis capitata* (Rep. Consultants Mtg Vienna, 1985), IAEA, Vienna, 1985.
- [19] MORTON, R.A., SINGH, R.S., *Biochem. Genet.* **23** (1985) 959.
- [20] KOROCHKIN, L.I., *Genetics* **107** (1984) 558.

SELECTION FOR RESISTANCE IN THE MEDITERRANEAN FRUIT FLY FOR GENETIC SEXING IN STERILE INSECT TECHNIQUE PROGRAMMES*

Y. RÖSSLER

The Israel Cohen Institute for Biological Control,
Citrus Marketing Board of Israel,
Rehovot, Israel

Abstract

SELECTION FOR RESISTANCE IN THE MEDITERRANEAN FRUIT FLY FOR GENETIC SEXING IN STERILE INSECT TECHNIQUE PROGRAMMES.

The construction of 'genetic sexing' strains of the Mediterranean fruit fly (medfly) is essential for economical and efficient mass rearing and proper execution of a sterile insect technique programme. The paper describes attempts to construct such strains via selection for resistance to three chemical agents: potassium-sorbate, Avermectin® and Cyromazine®. Dose mortality response studies, as well as the selection process, are described. With all three chemical agents, 'resistant' strains have been developed. The mode of inheritance of potassium-sorbate has been analysed, and it seems to depend on multiple and non-linked loci. The selection for resistance to Avermectin was discontinued owing to inconsistent results, although increased immunity was observed. Resistance to Cyromazine was also observed (five times) and it seems that it is regulated by a single recessive gene.

1. INTRODUCTION

Concentrated efforts have been directed during the last decade at developing economical 'genetic sexing' methods for the Mediterranean fruit fly (medfly) for use in mass rearing in major sterile insect technique (SIT) programmes against that pest [1]. These efforts were formalized in 1980 in an FAO/IAEA Consultants Meeting, which recommended the channelling of resources into such studies [2]. Various laboratories have since become involved. Initial efforts were directed at developing 'genetic sorting' methods, based on sex limited pupal colour differences [3-7], utilizing the limited number of morphological mutants which were available in few laboratories at the time [8].

The genetic sorting medfly lines (which are now available and might be used), nevertheless, have their limitations. As sorting is carried out in the pupal stage only, the cost of mass rearing is not reduced. An additional limiting factor is the need for costly electro-optical machinery for the sorting process.

* Research carried out with the support of the IAEA under Research Contract No. 2797/RB and under Binational Agricultural Research and Development Grant No. US-816-84.

For these reasons, research efforts were directed at developing sexing methods that will eliminate the females at an early stage in the mass rearing process (eggs or first instar larvae). Such 'sex killing' methods require differential responses of the two sexes to conditional lethals that could be incorporated into the mass rearing process. In the absence of such sex linked differences, selection, or methods of genetic engineering, are employed to construct the required strains.

During the last five years our efforts were concentrated on selecting medfly strains with resistance to certain chemicals, including pesticides. We avoided using pesticides which were already being used, or might be of use, in regular medfly control so as not to jeopardize their future use by accidental release of resistant and fertile flies into the natural populations. This approach limited the scope of the chemicals that could be studied. It was, and it still is, the author's conviction that as long as we cannot guarantee against such accidental release and do not have at hand sound alternative methods, we should not jeopardize our only method of controlling this pest. This approach is even more justified when such studies are being carried out in a medfly infested country. Three chemicals were used in our laboratory for these studies: potassium-sorbate, Avermectin® and Cyromazine®.

2. POTASSIUM-SORBATE

Potassium-sorbate (KC_5H_7COO) is widely used in the food industry as a food preservative with fungistatic properties. In 1982, we tried to replace the rather expensive sodium hydroxybenzoate with a less expensive preservative for our medfly larval media and potassium-sorbate (PS) seemed a likely candidate. It soon became evident that concentrations of more than 0.2% PS in the diet resulted in a progressively increasing rate of mortality of the exposed larvae and also of the eggs (Fig. 1).

2.1. History of the selection process

Selection for potassium-sorbate resistance began in February 1982 with a larval diet containing 0.4% PS. The concentration of PS was raised to 0.7% in September 1983, following 21 generations of selection at 0.4% PS, as the survival of larvae on 0.4% PS reached a plateau of above 60% from the 18th generation onward (Fig. 2).

Selection of single family lines on 0.7% PS was initiated in April 1984, following nine generations of selection on a diet of 0.7% PS and the current PS-16 line was established after five consecutive single pair crosses and selection at the 0.7% PS level. The effect of PS selection was not monitored for each and every generation. It was evident, however, that these lines developed high levels of resistance to PS. A comparison of the survival of the F_{18} generation of the 0.7% PS line with a wild type line is presented in Table I. The single pair crosses and the family selection did not enhance the selection results (Table II) and the

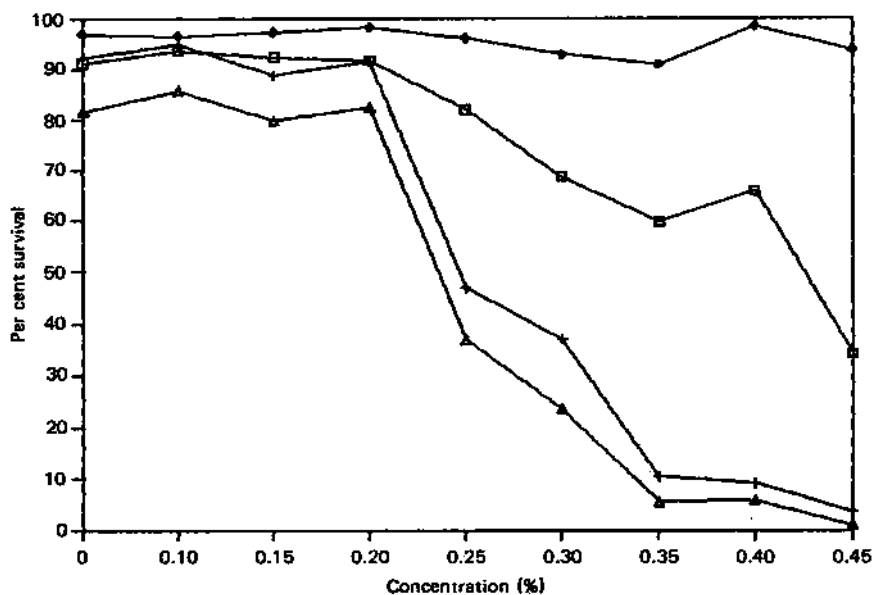

FIG. 1. Dose-mortality response of the medfly to potassium-sorbate in the larval diet. □: hatch; +: pupae; ◇: adults; Δ: total.

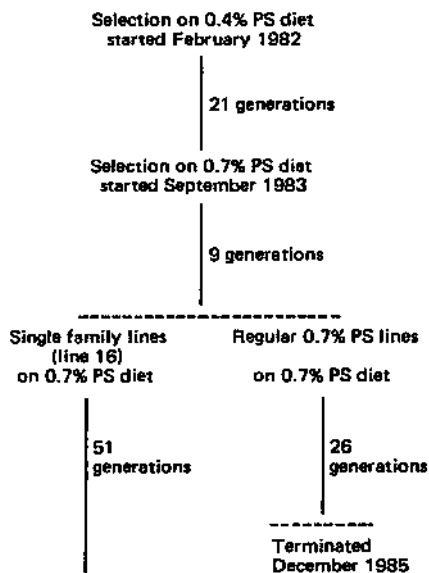

FIG. 2. Selection of potassium-sorbate resistant lines in the medfly — outline and history.

TABLE I. DOSE MORTALITY RESPONSE OF THE F_{18} GENERATION OF THE 0.7% PS LINE (= F_{39} FROM THE START OF THE SELECTION PROCESS)

PS concentration (%)	Percentage of larvae surviving	
	Wild type	PS line
0.0	86.8 ± 8.5	93.2 ± 4.6
0.2	51.6 ± 34.6	
0.4	5.9 ± 1.8	70.2 ± 21.4
0.7	4.3 ± 3.1	74.1 ± 6.8
1.0	6.4 ± 2.8	66.8 ± 26.3
2.0	0	4.3 ± 6.9

TABLE II. SURVIVAL OF THE F_{10} GENERATION OF THE SINGLE PAIR FAMILY LINE (PS-16) AND THE F_{21} GENERATION OF THE REGULAR 0.7% PS LINES ON A PS DIET

PS concentration (%)	Percentage of larvae surviving	
	F_{21} of 0.7% PS	F_{10} of PS-16
0.0	75.6 ± 9.5	41.3 ± 6.7
0.7	57.5 ± 8.2	54.0 ± 16.3
1.0	57.6 ± 21.4	68.1 ± 26.3
1.5	17.2 ± 6.9	12.6 ± 3.4

F_{10} generation of the selected single pair family did not differ from the concurrent F_{21} generation of the regular 0.7% PS line.

2.2. Toxicity of PS and sorbic acid for eggs of the medfly

The technique for selection using PS was based on placing eggs of the medfly on black blotting paper soaked with a 0.5% sodium hydroxybenzoate solution, on top of a larval diet containing PS, in Petri dishes. Egg hatch was reduced by the diet, probably through the diffusion of soluble ingredients into the blotting paper. However, this seemed to be extremely inconsistent and not related to the apparent progress of the selection process. A series of tests was set up to determine the causes

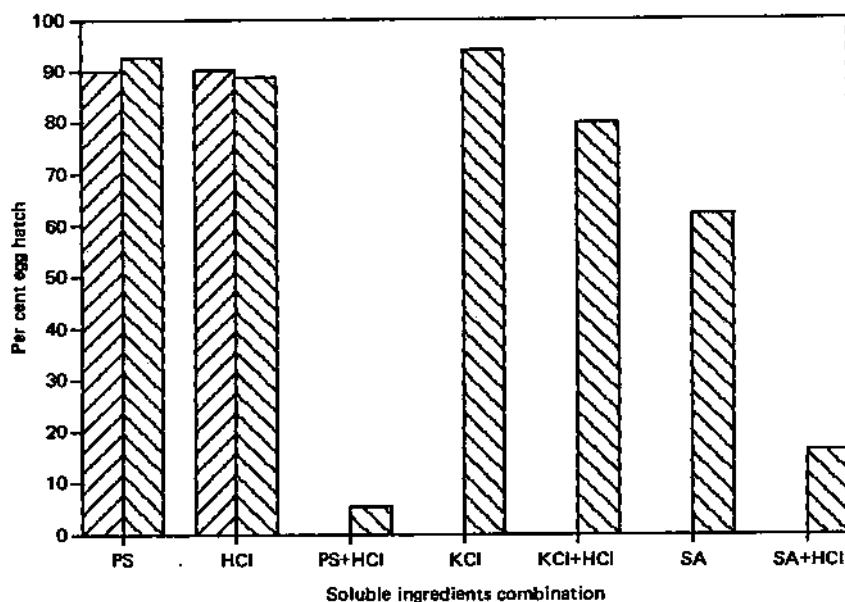

FIG. 3. Effect of potassium-sorbate and sorbic acid, in combination with hydrochloric acid, on egg hatch of the medfly. ▨: 0.4% PS, F_7 ; ▩: 0.7% PS, F_{21} .

TABLE III. EFFECT OF pH ON THE TOXICITY OF PS AND SA TO MEDFLY EGGS

pH solution	Percentage of egg hatch in solutions of		
	Control	0.4% PS	0.4% SA
<i>Wild type line</i>			
3.0	73.8	0.4	0.8
4.0	94.0	0.3	0.5
5.5	93.7	93.3	32.1
<i>0.7% PS (F_{20}) line</i>			
3.0	86.2	18.8	38.9
4.0	88.7	18.2	38.3
5.5	80.2	87.9	86.3

of this phenomenon. Eggs were soaked in solutions containing various combinations of the soluble ingredients of the diet (Na-methyl-hydroxybenzoate, HCl and PS) and in a separate series we also included sorbic acid (SA) and potassium chloride to test for the possible effect of the potassium ion in the PS.

The results showed that PS or SA alone had no effect on egg hatch and that the combination of PS or SA with HCl severely affected egg hatch (Fig. 3). Further tests with PS and SA in buffer solution (citric acid and sodium citrate) established that the toxic effects of PS and SA on eggs is negatively related to the environmental pH (Table III).

Since the pH in the medfly larval diet was 4.0 on preparation, the inconsistency in egg hatch could be attributed to changes in the pH in the various preparations and also in the differential rate of infiltration of the soluble ingredients of the diet into the blotting paper placed on top of the diet. However, even when considering that fact, it was still evident that selection did increase egg resistance to PS. Nevertheless, we decided to continue selection and maintenance of the PS lines by exposing only the hatched eggs to the PS diet. Eggs are not placed directly on the diet, which is added only after egg hatch.

2.3. Mode of inheritance of resistance to PS

The mode of inheritance of resistance to PS was checked three times during the selection process: in September 1983 with the F_{19} generation of the 0.4% PS line, in October 1984 with the F_{21} generation of the 0.7% PS line and in April 1985 with the F_{14} generation of the single pair family line (PS-16).

The PS flies were crossed reciprocally with wild type flies. The F_1 generation flies were 'sibmated', or back-crossed reciprocally, with wild type flies or flies from the PS line. Each cross was carried out with a population of not less than 50 pairs. The larvae in all of these crosses were reared on a diet containing PS (0.4% in the first test and 0.7% in the later two tests) and on a regular larval diet as control. As no differences were observed between the reciprocal crosses, we pooled the data of these crosses and used Abbott's correction method for the presentation of the data (Fig. 4).

All three tests showed a persistent pattern of response. The wild type flies (WT×WT) obviously had the lowest survival values and the PS flies (PS×PS) showed the highest values. All other crosses showed intermediate resistance to PS and the survival of the larvae of these crosses seemed to depend upon the amount of genetic material contributed by each parent (F_1 ×PS having higher survival levels than F_1 ×WT, etc.). The results suggested therefore that PS resistance was not dominant and probably involved more than one locus.

An attempt to localize the PS resistant genes was carried out by crossing PS males with females of the 'apricot-eye', 'dark-pupa', 'white-pupa' and 'brown-orange-eye' lines (chromosomes 4, 3, 5 and 2 or 6, respectively) [9]. The F_1 generation males of each cross were then back-crossed with the respective mutant

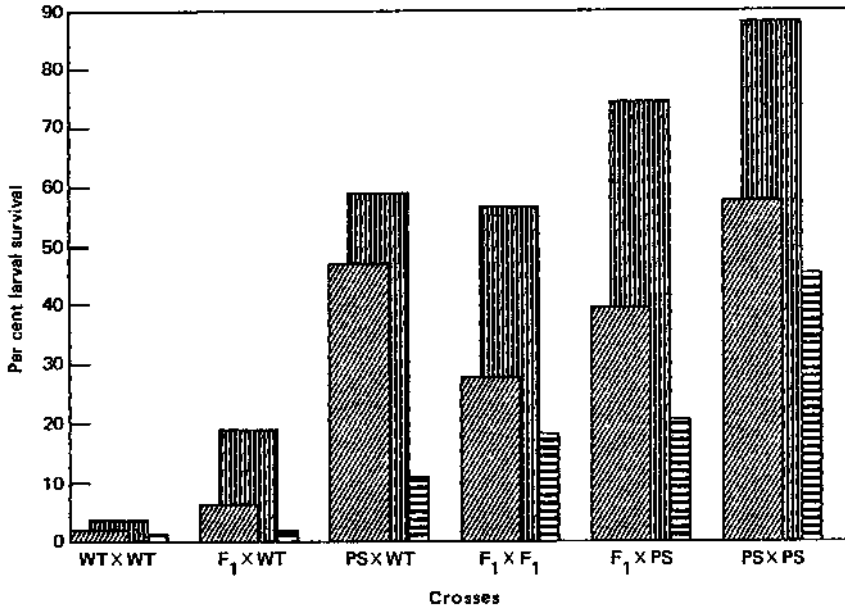

FIG. 4. Mode of inheritance of potassium-sorbate resistance for the medfly (see text for details).
 ▨: 0.4% PS, F₁; ▤: 0.7% PS, F₂; ▤: PS-16, F₁.

females, the F₂ generation larvae were reared on a 0.7% PS diet and the phenotypes of the F₃ generation offspring were then scored. No cross yielded results that might point to any linkage between PS resistance and a particular chromosome. Thus, unless the PS gene is located on the still unmarked autosome, it is a polygenic inter-chromosomal trait. The PS line is still being maintained in our laboratory and is available for further experiments.

3. AVERMECTIN

Avermectin (C₄₈H₇₂O₁₄+C₄₇H₇₀O₁₄) is a macrolactone streptomycete derived insecticide, discovered and developed by Merck, Sharp and Dome Research Laboratory [10]. The commercial preparation contains 1.8% active ingredients.

Preliminary tests in our laboratory failed to reveal any effect of Avermectin (MK) on medfly larvae when incorporated in the larval diet. Additional tests showed that exposure of freshly laid eggs (0-3 h old) to MK solutions (and subsequent rearing of the larvae on a regular larval diet) affected not only egg hatch, but also the survival of the first and later instar larvae. We also found that varying the duration of exposure between 0.5 and 4 h had little effect on the toxicity of MK. We thus

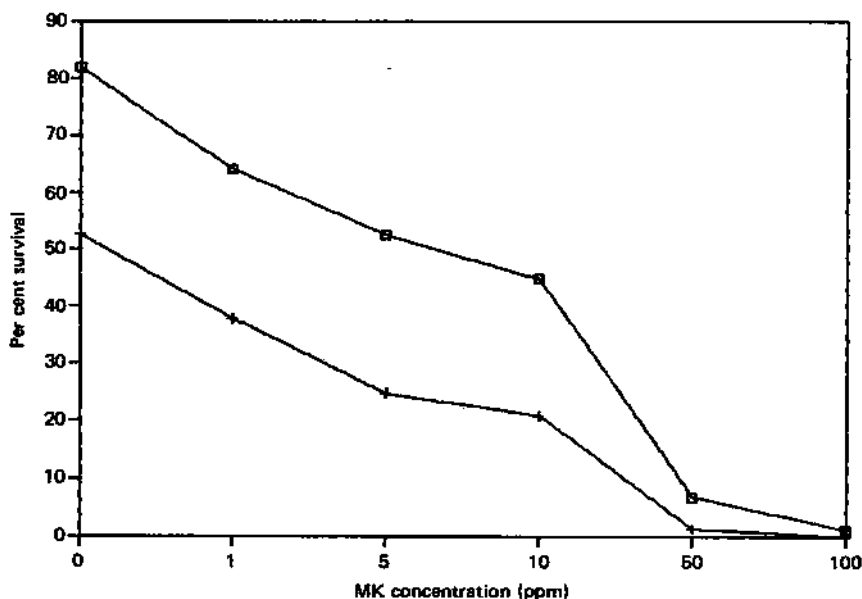

FIG. 5. Dose-mortality response of the medfly to Avermectin (exposure of eggs for 2 h). □: larvae; +: total.

carried out the dose response tests by exposing freshly laid eggs for 2 h to varying concentrations of MK (Fig. 5). A sharp reduction of survival was observed between 10 and 50 ppm of MK. The latter concentration was thus used in the selection programme. Selection began in December 1985 and was carried out for 14 generations on 50 ppm of MK. From the 15th generation onwards, the concentration of MK was raised to 100 ppm, the level at which the line is currently being maintained.

The line seemed to respond very quickly to the selection pressure. Egg hatch reached c. 90% in the second generation and first larvae survival reached c. 80% after five generations. The results with the second and third instar larvae were rather erratic, though egg hatch reached 90% (of the hatched eggs) after 14 generations of selection.

Although selection seemed to proceed in the right direction, we had to abandon further studies with MK as we obtained erratic responses to MK with the wild type line during the test period. Whereas 50 ppm MK resulted in 6.9% survival of wild type larvae (pupation/hatch) at the initiation of our studies, it resulted in 20.7% survival nine generations later in the same line without selection (as compared with 77.7% in the MK line) and 47.9% survival 14 generations later (as compared with 81.9% in the MK line). It seemed that there was either a problem with the

exposure method (which remained the same throughout the period), or there was an inconsistency in the MK used (we used more than one batch of MK), or breeding or unexpected genetic changes in the wild type line caused these results. Raising the concentration of MK to 100 ppm, or even 200 ppm, did not change that trend and resulted in even more puzzling data (100 ppm, wild type line — 22.4%, MK line — 64.3%; 200 ppm, wild type line — 45.3%, MK line — 80.6%).

4. CYROMAZINE

Cyromazine is a triazine compound with the chemical formula 2-cyclopropylamino-4,6-diamino-5-triazine. It belongs to the s-triazine group which shows insect growth regulator (IGR) activity and some chemosterilant effects. The compound Cyromazine (Neforex, Larvadex) is a stomach poison which was found to be extremely active in the laboratory and in the field against a variety of dipterous larvae [11, 12] and has a low mammalian toxicity. These characteristics made it a desirable candidate for use in genetic sexing of the medfly, if selection for resistance is achieved.

We used the 50% WP preparation and incorporated it into the regular larval diet. Preliminary tests were carried out with concentrations of 0.1, 1 and 10 ppm.

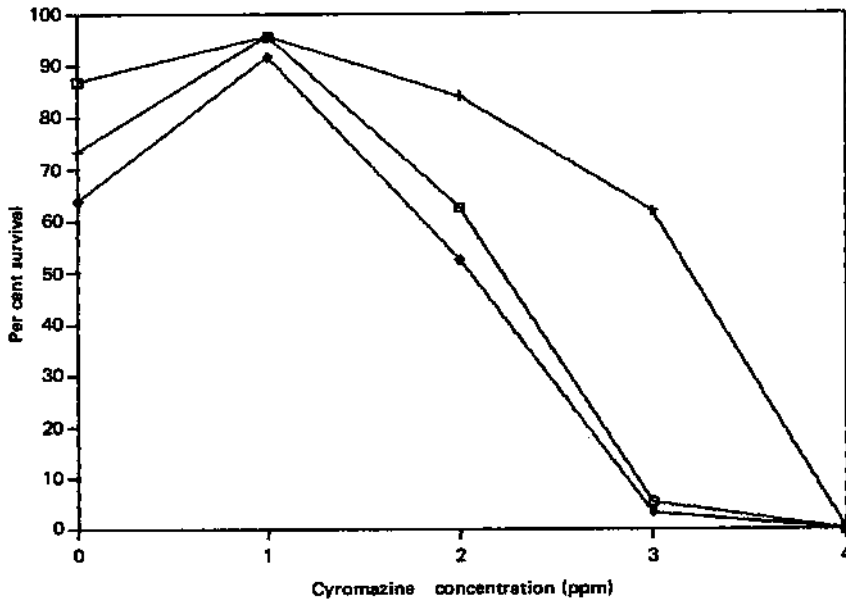

FIG. 6. Dose-mortality response of the medfly to Cyromazine in the larval diet. □: larvae; +: adults; ◇: total.

The compound had no effect on the eggs placed on top of the diet (in contrast to the effect of PS on such eggs). It also did not affect the first instar larvae, which moved from the black blotting paper to the diet with no difficulties. The mortality rates of later instar larvae were rather low with the 1 ppm diet, but reached 100% in the 10 ppm diet. We thus tested concentrations of 1, 2, 3 and 4 ppm Cyromazine in the larval diet (Fig. 6). Only 6.19% of the larvae survived the 3 ppm diet. The effect of Cyromazine was observed not only in the larval stage (pupation), but also on the pupal shape (elongation of the pupae) and subsequent reduction of adult emergence (66.2%).

We therefore started the selection with 3 ppm Cyromazine in the larval diet. After six generations, the survival of larvae reached 55%. Only normally shaped pupae were produced and adult emergence reached 92.8%. We thus raised the concentration of Cyromazine to 5 ppm for an additional four generations. We then raised the discriminating dose again to 10 ppm for four additional generations and raised it again to 20 ppm, at which level it remains now. The levels of survival obtained at 20 ppm after four generations (totalling 14 generations from the start) reached 78.4% for larvae and 82.2% for adults emerging from the surviving larvae. That level has been maintained for five generations and we seemed to have reached the plateau.

Initial studies on the mode of inheritance were carried out in the ninth generation. Cyromazine selected flies were reciprocally crossed with wild type flies. The F_1 generation flies were sibmated and back-crossed with wild type and Cyromazine selected flies. Survival of the various types was then studied on a 5 ppm larval diet. The results did indicate that Cyromazine resistance was regulated by a single recessive gene. These studies will be further substantiated and published upon completion.

5. CONCLUSIONS

The report summarizes five years of concentrated efforts in our laboratory to obtain medfly strains resistant to specific chemicals, for use in genetic sexing in SIT programmes. Similar efforts have been carried out in at least five other laboratories around the world [13] using alcohol (ADH), dieldrin, malathion, purine, etc. [14-17]. Until now, no usable genetic sexing medfly strain based on sex killing has been developed (neither with chemical resistance nor with other conditional lethals). The results so far are somewhat disappointing. The situation is even more discouraging if we consider the fact that the pest has been controlled for thirty years now with malathion in many countries throughout the world and no case of resistance has yet been reported. Attempts to develop resistance to malathion in the laboratory have also failed [18]. Be it a coincidence or an inheritable trait of that species, it seems that the conventional methods of selection and the exclusive reliance on naturally occurring genes for resistance in medfly populations could lead to a dead end. It is also possible that the medfly populations used in such studies had a very narrow

genetic background and did not represent the whole range of genetic variability available in that species. If that is the case, then efforts should be directed to broadening the genetic raw material available by introducing populations (into laboratories, not into field populations) from the area of origin of the species (East African countries). Another approach would be the inclusion of new and more sophisticated methods of genetic engineering and recombinant DNA technology [19] in the hope that they will lead to the breakthrough which, unfortunately, has not been achieved until now. This is not to say, however, that we should abandon the conventional methods used so far, as the arsenal of possible chemical candidates and other conditional lethals has not yet been depleted.

REFERENCES

- [1] INTERNATIONAL ATOMIC ENERGY AGENCY, Development of Sexing Mechanisms in Fruit Flies through Manipulation of Radiation Induced Conditional Lethals and Other Genetic Measures (Proc. Research Co-ordination Mtg Colymbari, Crete, 1986), IAEA, Vienna, 1986, p. 134.
- [2] INTERNATIONAL ATOMIC ENERGY AGENCY, Genetic Sexing Mechanism for the Mediterranean fruit fly, *Ceratitis capitata* (Rep. Consultants Mtg Vienna, 1980), IAEA, Vienna, 1980.
- [3] RÖSSLER, Y., Automated sexing of the Mediterranean fruit fly: The development of strains with inherited, sex-limited pupal color dimorphism, *Entomophaga* **24** (1979) 411.
- [4] RÖSSLER, Y., "69-apricot" — A synthetic strain of the Mediterranean fruit fly, *Ceratitis capitata* (Diptera:Tephritidae), with sex-limited pupal color and eye color marker, *Entomophaga* **25** (1980) 275.
- [5] SMITTLE, B.J., SEAWRIGHT, J.A., BIRKY, B.K., Use of commercial color sorter to separate sexes of stable fly (Diptera:Muscidae) pupae from a genetic sexing strain, *J. Econ. Entomol.* **79** (1986) 877.
- [6] WHITTEN, M.J., Automated sexing of pupae and its usefulness in control by sterile insects, *J. Econ. Entomol.* **62** (1969) 272.
- [7] WALDER, J.M.M., SEAWRIGHT, J.A., Genetic method for the separation of males and females of the house fly, *Musca domestica* (Diptera:Muscidae), *J. Econ. Entomol.* **78** (1985) 1030.
- [8] RÖSSLER, Y., "Genetic sexing of insects by phenotypic characteristics, with special reference to the Mediterranean fruit fly", *Sterile Insect Technique and Radiation in Insect Control* (Proc. Int. Symp. Neuherberg, 1981), IAEA, Vienna (1982) 291-306.
- [9] Second Medfly Genetics Information Circular, Insect and Pest Control Section, Joint FAO/IAEA Division, IAEA, Vienna (1987) 15.
- [10] SCHMIDT, C.D., Activity of Avermectin against selected insects in aging manure, *Environ. Entomol.* **12** (1983) 455.
- [11] EL-OSHAR, M.A., MOTOYAMA, N., HUGHES, P.B., DAUTERMAN, W.C., Studies on cyromazine in the house fly, *Musca domestica* (Diptera:Muscidae), *J. Econ. Entomol.* **78** (1985) 1203.
- [12] FREIDEL, T., McDONNELL, P.A., Cyromazine inhibits reproduction and larval development of the Australian sheep blow fly (Diptera:Calliphoridae), *J. Econ. Entomol.* **78** (1985) 868.
- [13] ROBINSON, A.S., RÖSSLER, Y., in *Development of Sexing Mechanisms in the Mediterranean Fruit Fly, Ceratitis capitata*, through Manipulation of Radiation Induced Conditional Lethals and other Genetic Measures (Rep. Consultants Mtg Vienna, 1987), IAEA, Vienna, 1987, p. 6.

- [14] BUSCH-PETERSEN, E., WOOD, R.J., The isolation and inheritance of dieldrin resistance in the Mediterranean fruit fly, *Ceratitis capitata* (Wiedemann) (Diptera:Tephritidae), Bull. Entomol. Res. **76** (1986) 567.
- [15] ROBINSON, A.S., RIVA, M.E., ZAPATER, M., Genetic sexing in the Mediterranean fruit fly, *Ceratitis capitata*, using alcohol dehydrogenase locus, Theor. Appl. Genet. **72** (1986) 455.
- [16] SAUL, S.H., Genetic sexing in the Mediterranean fruit fly, *Ceratitis capitata* (Wiedemann) (Diptera:Tephritidae): Conditional lethal translocations that preferentially eliminate females, Ann. Entomol. Soc. Am. **77** (1984) 280.
- [17] WOOD, R.J., MARCHINI, L.C., BUSCH-PETERSEN, E., HARRIS, D.J., "Genetic studies of tephritid flies in relation to their control", The Fruit Fly Problem (Proc. Int. Symp. Naha, Okinawa, 1980), National Institute of Agricultural Science, Yatabe, Ibaraki (1980) 47.
- [18] KOREN, B., YAWETZ, A., PERRY, A.S., Biochemical properties characterizing the development of tolerance to malathion in *Ceratitis capitata* Wiedemann (Diptera:Tephritidae), J. Econ. Entomol. **77** (1984) 864.
- [19] INTERNATIONAL ATOMIC ENERGY AGENCY, Application of Genetic Engineering and Recombinant DNA Technology in the Development of Genetic Sexing Mechanism for the Mediterranean Fruit Fly, *Ceratitis capitata* Wied. (Rep. Consultants Mtg Vienna, 1985), IAEA, Vienna, 1985, p. 18.

Invited Paper

STATUS OF MOLECULAR GENETIC STUDIES IN THE MEDFLY, *Ceratitis capitata*, IN RELATION TO GENETIC SEXING

A.S. ROBINSON, C. SAVAKIS, C. LOUIS
Institute of Molecular Biology and Biotechnology,
Research Center of Crete,
Heraklion, Crete,
Greece

Abstract

STATUS OF MOLECULAR GENETIC STUDIES IN THE MEDFLY, *Ceratitis capitata*, IN RELATION TO GENETIC SEXING.

A review of the current status of the molecular genetics of the Mediterranean fruit fly (medfly), *Ceratitis capitata*, with particular emphasis on the development of genetic sexing systems is presented. Rapid developments in the work on the molecular genetics of *Drosophila melanogaster* are beginning to play a prominent role in the expansion of genetic sexing to include molecular approaches. For example, the increasing availability of cloned genes from *Drosophila* has permitted the homologous sequences from the medfly genome to be identified. If homologous genes are identified, they can be rapidly mapped on the polytene chromosomes by in situ hybridization. Germ line transformation is now routine in *Drosophila* and many attempts have been made to transform the medfly using the same system, to date without success. A P-element excision assay in *Anastrepha suspensa* has indicated that in this species also, P-element transformation is unlikely to be successful. Target genes to be potentially used in transformation fall into two classes, sex killing and sex transformation, and progress in and possibilities for both are discussed. Recent data on sex regulation in *Drosophila* offer new approaches for sex killing systems. Finally, since the genome of the medfly is sparsely mapped, it is suggested that a search should be made for restriction fragment length polymorphisms. These could be rapidly assigned to chromosome position using in situ hybridization and mapped using conventional genetic analysis.

1. INTRODUCTION

The advantages of a genetic sexing system for use in the sterile insect technique (SIT) method of control of the Mediterranean fruit fly (medfly), *Ceratitis capitata*, have been well documented [1-3] and classical genetic techniques, as successfully developed for mosquitoes [4-9], were initially used. These techniques have relied exclusively on the use of male linked translocations, whereby a selectable gene is 'relocated' on the male determining chromosome. Using this principle, several prototype genetic sexing systems have been developed in *C. capitata* using pupal colour [10, 11] or resistance to a particular chemical [12, 13]. The major weakness of the use of translocations is the problem of strain stability which, under normal laboratory

rearing, presents no problem, but which, under mass rearing conditions, can rapidly lead to the disintegration of the strain [14]. These difficulties have stimulated work on the development of the molecular biology of this species in order to achieve genetic sexing by the introduction of relevant genes into *C. capitata* by germ line transformation.

In another distantly related fruit fly, *Drosophila melanogaster*, germ line transformation has been developed using the P-transposable element system [15, 16]. Transformation is defined as the stable integration of functional exogenous DNA in the germ line. Germ line transformation was rapidly exploited by the 'drosophilists' to study problems related to gene function and regulation and has since become routine. The extension of this technique to insects of economic importance offers new possibilities to applied entomologists. In December 1985, the IAEA convened an Advisory Group Meeting to assess the feasibility of using gene transfer techniques for the development of genetic sexing [17]. Owing to that and other related initiatives, both public and private, molecular studies on *C. capitata* have started. This paper will summarize the different approaches tried so far, the results obtained and make some suggestions as to where the emphasis should be placed in the next few years.

2. PROBING THE *C. capitata* GENOME WITH *Drosophila* SEQUENCES

Drosophila melanogaster has a genome size of 170 000 kbase and approximately 10% of its non-repetitive fraction has already been cloned [18]. In *Drosophila*, in situ hybridization [19] using polytene chromosomes enables any cloned sequence to be localized cytologically. Polytene chromosomes can now be prepared from the medfly [20, 21] and have been used for in situ hybridization [22]. In addition, *Drosophila* probes can be used to screen for related sequences in other species using Southern blotting. These can be the first step to clone specific genes from the medfly even when a conventional genetic analysis cannot be carried out. *Drosophila* probes can, therefore, be used (1) to increase the number of mappable loci in the medfly and (2) to isolate and study genes of specific importance for genetic sexing.

2.1. Xanthine dehydrogenase (XDH)

Drosophila melanogaster flies lacking active XDH are sensitive to purine and they express the mutant eye phenotype *rosy* [23]. In the medfly, Saul [24] has analysed a phenotypically equivalent strain and shown that it could have potential for genetic sexing [13]. The XDH locus has been cloned in *Drosophila* [25] and a labelled probe was successfully hybridized with Southern blotted genomic DNA from the medfly [26]. Thus, it should now be easy to map this locus on the medfly polytene chromosomes using in situ hybridization. The structural locus for XDH has already been assigned to its mitotic chromosome using conventional mapping [27].

2.2. Vitellogenins

Female specific promoters will be important components of genetic sexing systems based on molecular genetics (see Section 3.2). One source of such promoters could be the genes which encode the vitellogenins, the precursors of the yolk proteins. The genes are only expressed in the female fat body and ovaria in most Diptera. Using a cDNA probe from *D. grimshawi*, five clones have been identified in the medfly and their sequence homology with *D. melanogaster* is at present being determined [28]. Using in situ hybridization, the sequences have been localized to a single band on chromosome 5 [22]. In *Anastrepha suspensa*, putative yolk protein clones have been identified using cDNA probes from *D. melanogaster* [29].

2.3. Alcohol dehydrogenase (ADH)

Alcohol dehydrogenase is a useful enzyme for genetic sexing [30] and in the medfly, ADH mutants at *Adh 1* have been isolated and studied [31]; in the medfly, two ADH⁻ genes are present [32]. Initial attempts using a 2 kb DNA fragment spanning the 5' half of the *D. melanogaster* gene under low stringency conditions have failed to identify a closely related sequence in the medfly [33]. The biochemical data indicating significant differences between the ADH molecules in the two species [32] perhaps explain the lack of hybridization. Saul has also not been successful using an ADH *Drosophila* probe [34].

2.4. Chorion genes

Another source of female specific promoters are the genes encoding chorion polypeptides, which have been studied extensively in *Drosophila* [35]. Medfly genomic clones containing chorion gene homologues have been isolated using *Drosophila* probes and are currently being characterized [36].

2.5. Other genes

It is certain that many *Drosophila* genes will have their homologues in the medfly genome and they could be of immense help in providing the medfly geneticist with much needed 'genetic hardware'. Genes that show high conservation and/or which are of direct interest for genetic control have obvious priority. Larval serum protein genes have been assigned to their mitotic chromosomes in the medfly [27] and, as they have been cloned in *Drosophila* and are expected to show high conservation, in situ mapping should be carried out. The heat shock protein (HSP) genes are another gene family which could be used and preliminary data on the biochemistry of HSPs are available for the medfly [37].

The molecular analysis of sex regulation in *Drosophila* has made great progress. Following an initial X:A ratio recognition, a whole cascade of genes is

involved in maintaining normal sexual development and mutations at some of these loci have specific effects on sex determination. Because of the direct relevance of this to genetic sexing, the genome of the medfly should be probed with cloned sex determination genes from *Drosophila*, e.g. *Sx1*, *tra*, *tra-2*, etc.

In many insects mutations at the acetylcholinesterase locus can lead to high levels of insecticide resistance [38]. The locus is therefore of great economic importance. Surprisingly, no insecticide resistance has yet been confirmed in the medfly despite widespread and intensive use of insecticidal sprays. In *Drosophila*, the gene *Ace* has been cloned [39] and it is expected to show high conservation and it could be used to probe for the homologous gene in the medfly.

3. TRANSFORMATION

In *Drosophila*, stable germ line transformation has been developed through the use of P-element based vectors. The P-element is one of the many transposable elements found in *Drosophila* and it is included in the moderately repetitive component of nuclear DNA. The frequency with which different elements transpose varies and appears to be under both genetic and environmental control. In *Drosophila*, the P-element induces the hybrid dysgenesis syndrome [40], which is characterized by an increased number of mutations, male recombination, chromosome breakage and gonadal dystrophy in the progeny of specific interstrain crosses. The syndrome is only seen when males carrying the P-elements are mated with females lacking them, whereas the reciprocal cross is normal. In the dysgenic state the P-element becomes 'de-repressed' as the females have no P-element suppressor in the egg cytoplasm. The complete element is 2.9 kb long and contains four non-overlapping reading frames [41]. For transformation, two P-elements are injected into pre-blastoderm embryos: one defective and carrying the required gene and one intact element which provides transposase for the integration of the defective P-element. The system has been successfully extended to *D. simulans* [42] and *D. hawaiiensis* [43].

3.1. Transformation results

The results of transformation attempts in the medfly using various helper and vector elements are shown in Table I. The helper elements p π 25.7 Δ 2-3 and pUCHs π Δ 2-3 used in these experiments have been modified by removing an intron [44]. In *Drosophila*, this intron is spliced only in germ line cells; the modified helpers express transposase in *Drosophila* somatic tissues [44]. The vectors are (1) pUCHsneo, conferring resistance to the antibiotic G418 [45] and (2) pNM, a derivative of pUCHsneo containing the *D. melanogaster Adh* gene [46]. Out of a total of 6250 embryos injected, 8.1% survived to adulthood; emerging adults were inbred and G₁ larvae reared in medium containing 400 μ g/mL G418. Even though a small proportion of the larvae survived the selective medium, none showed evidence of

TABLE I. RESULTS OF TRANSFORMATION EXPERIMENTS IN *C. capitata* USING MODIFIED P-ELEMENTS FROM *D. melanogaster*

	G ₀ generation			G ₁ generation
	No. of embryos injected	No. of larval survivors	No. of adult survivors	No. of larvae screened
pNM/p π 25.7 Δ 2-3 (0.5 mg/mL each)	2850	418	130	1171
pNM/p π 25.7 Δ 2-3 (0.25 mg/mL each)	1800	552	228	5600
pUChsneo/pUChs π Δ 2-3 (0.25 mg/mL each)	1100	362	137	3900
pNM/pUChs π Δ 2-3 (0.25 mg/mL each)	500	88	11	120
Total	6250	1420	506	10 791

P-element integration, as evidenced by Southern blotting, and none bred true for G418 resistance.

An equivalent impasse has also been reached by other research groups [47, 48]. Closely related studies with *A. suspensa* using a P-element excision assay suggested that P-elements were not functioning in this species [29]. (However, a stable integration of exogenous DNA has been demonstrated in a mosquito after injecting *Drosophila* P-elements, though the single event reported does not seem to be a typical P-mediated event [49].) Taken together, all of these results suggest that the system as used in *Drosophila* will not work for at least two fruit fly species. Three options remain: (a) further modification of P-elements; (b) use of other *Drosophila* elements, e.g. Hobo (see Ref. [50]); or (c) isolation of transposable elements with similar properties from the medfly. In this respect, a systematic search for hybrid dysgenic symptoms between different medfly populations could be extremely productive.

3.2. Target genes for transformation

It is important to realize that although transformation techniques have the highest priority at the moment, they are only a means to an end. The aim is to 'transform' the medfly with genes that could be used for genetic sexing. For sex killing, the 'conventional' genes, such as *Adh* and *Xdh*, might prove problematical for different reasons. ADH is complicated, as there are two loci, and XDH relies for sexing on an extremely expensive chemical. Nevertheless, assuming that null lines for these

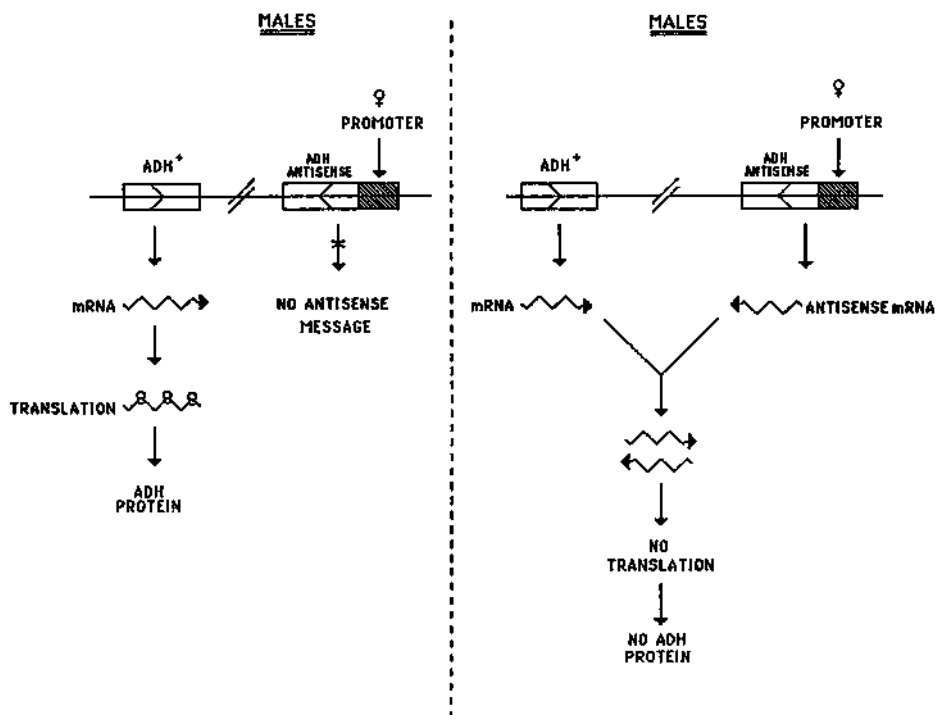

FIG. 1. Use of antisense RNA to induce loss of function.

enzymes could be selected, how could the transformation then be used? The ideal situation would be to transform an ADH^- line with an ADH^+ gene under a male specific promoter; an equivalent system would be effective for XDH. In this construction, no translocation is necessary. One difficulty so far encountered in the medfly has been the selection of the null mutants, and perhaps transformation could be used to induce sex specific loss of function [29] by the use of antisense RNA (Fig. 1). This technique could, in theory, be used to cause loss, or partial loss, of function of any specific gene once adequate amounts of its antisense RNA are expressed. So far, it has only been used to induce phenocopies following injection of antisense RNA into embryos of *D. melanogaster* [51].

Recent developments in the understanding of sex regulation in *Drosophila* [52] might open up new possibilities for genetic sexing of medflies. It now appears that the major factor dictating male or female development is in the differential splicing of the primary transcripts of a series of sex determining genes to produce mature messenger RNAs [53]. Males and females transcribe the same primary transcripts, but only the females can splice the transcript in such a way as to translate the correct

polypeptide and so maintain development in the female mode. If there is an equivalent system in the medfly, then the following could be possible. Assemble a construct in which a *Drosophila* sex gene, e.g. *tra* [54], is fused with a conditional lethal gene. If medflies are transformed with this construct, then in females the transcript would be correctly processed and the required protein produced, while in males no mature mRNA would be produced. Females could then be killed by applying the conditional constraint.

4. RESTRICTION FRAGMENT LENGTH POLYMORPHISM (RFLP)

The ability to develop genetic sexing techniques by either classical or molecular techniques is largely dependent on the availability of an adequate genetic 'tool box'. One of the essential components of this tool box is a collection of genetically mapped loci. In the medfly, both biochemical and morphological markers are limited in number and random variation at the molecular level could provide additional markers. The presence of polytene chromosome analysis in the medfly [20, 21] permits rapid assignment of polymorphic loci to chromosome position.

Variations at the molecular level are exposed by analysis of specific genomes with unique sequence probes. (As the genomes are analysed following digestion of DNA with restriction enzymes, this class of variation has been termed RFLP [55]). In human genetics, use of the technique has enabled several important genes to be cloned even in the absence of data at the protein level (see Ref. [56] for details). This technique, when applied to the medfly, would have important spin-offs, in addition to producing a large number of mappable loci. First, it could identify sex linked loci; at present, there is only one x-linked gene known [57]. Second, it would help to establish the genetic relationships between different populations in the field and in the laboratory. Third, it could identify a locus which could molecularly mark an insect population for release in an SIT programme. Fourth, if an RFLP site was shown to be tightly linked to a particular gene, it could provide a means of cloning the gene.

5. FINAL CONSIDERATIONS

At an international fruit fly meeting in 1986, a review was given of the possible application of genetic engineering to economically important insects [58]. This forum provides an opportunity to re-examine some of those possibilities in the light of results obtained in the intervening period and to suggest short term research priorities.

In concluding, the following should be considered:

- (1) The initial optimism that P-element mediated transformation would be effective in the medfly was to some extent misplaced and alternative systems will probably have to be sought.

- (2) A technique is now available to assay for P-element function in heterologous systems which does not entail any larval screening procedure.
- (3) The analysis of the sex determination system of *Drosophila* could provide an extremely powerful tool for the sex limited expression of conditional lethal genes.
- (4) As expected, some cloned *Drosophila* genes have been used to identify homologous sequences in the medfly, while others appear to show no homology.
- (5) The success in the analysis of polytene chromosomes in the medfly permits rapid assignment of cloned genes to their chromosomes.
- (6) RFLP analysis could provide a multifaceted approach to several basic and applied genetic problems in the medfly.

ACKNOWLEDGEMENTS

A.S. Robinson is in receipt of an EEC Training Fellowship in Molecular Biology and is on leave of absence from the Research Institute ITAL, Wageningen, Netherlands. F.C. Kafatos and M. Ashburner are thanked for their constructive support and discussions. The work at the authors' laboratory was supported by grants from the United States Department of Agriculture and the IAEA.

REFERENCES

- [1] INTERNATIONAL ATOMIC ENERGY AGENCY, Genetic Sexing Mechanism for the Mediterranean Fruit Fly (Rep. Consultants Mtg Vienna, 1980), IAEA, Vienna, 1980.
- [2] INTERNATIONAL ATOMIC ENERGY AGENCY, Development of Sexing Mechanisms in Fruit Flies through Manipulation of Radiation Induced Lethals and Other Genetic Measures (Proc. Research Co-ordination Mtg Vienna, 1980), IAEA, Vienna, 1980.
- [3] INTERNATIONAL ATOMIC ENERGY AGENCY, Development of Sexing Mechanisms in Fruit Flies through Manipulation of Radiation Induced Lethals and Other Genetic Measures (Proc. Research Co-ordination Mtg Vienna, 1985), IAEA, Vienna, 1985.
- [4] BAKER, R.H., SAKAI, R.K., RAANA, K., Genetic sexing for a mosquito sterile-male release, *J. Hered.* **72** (1981) 216.
- [5] CURTIS, C.F., Genetic sex separation in *Anopheles arabiensis* and the production of sterile hybrids, *WHO Bull.* **56** (1978) 453.
- [6] SEAWRIGHT, J.A., KAISER, P.E., SUGUNA, S.G., FOCKS, D.A., Genetic sexing strains of *Anopheles albimanus*, *Mosq. News* **41** (1981) 107.
- [7] McDONALD, P.T., ASMAN, S.M., A genetic sexing strain based on malathion resistance for *Culex tarsalis*, *Mosq. News* **42** (1982) 531.
- [8] ROBINSON, A.S., Genetic sexing in *Anopheles stephensi* using dieldrin resistance, *J. Am. Mosq. Cont. Assoc.* **2** (1986) 93.
- [9] CURTIS, C.F., AKIYAMA, J., DAVIDSON, G., A genetic sexing system in *Anopheles gambiae* species A, *Mosq. News* **36** (1976) 492.
- [10] RÖSSLER, Y., Automated sexing of *Ceratitis capitata*. The development of strains with inherited sex-limited pupal colour dimorphism, *Entomophaga* **24** (1974) 411.
- [11] ROBINSON, A.S., VAN HEEMERT, C., *Ceratitis capitata*, a suitable case for genetic sexing, *Genetica* **58** (1982) 229.

- [12] ROBINSON, A.S., RIVA, M.E., ZAPATER, M., Genetic sexing in the Mediterranean fruit fly using the ADH locus, *Theor. Appl. Genet.* **72** (1986) 455.
- [13] SAUL, S.H., Genetic sexing in the Mediterranean fruit fly *Ceratitis capitata*, conditional lethal translocations that preferentially eliminate females, *Ann. Entomol. Soc. Am.* **77** (1984) 280.
- [14] HOOPER, G.H., ROBINSON, A.S., MARCHAND, R., "Behaviour of a genetic sexing strain of Mediterranean fruit fly, *Ceratitis capitata*, during large scale mass rearing", *Fruit Flies (Proc. Int. Symp. Colymbari, Crete, 1986)* (ECONOMOPOULOS, A.P., Ed.), Elsevier, Amsterdam (1987) 349-362.
- [15] RUBIN, G.M., SPRADLING, A.C., Genetic transformation of *Drosophila* with transportable element vectors, *Science* **218** (1982) 348.
- [16] SPRADLING, A.C., RUBIN, G.M., Transposition of cloned P-elements into *Drosophila* germ line chromosomes, *Science* **218** (1982) 341.
- [17] INTERNATIONAL ATOMIC ENERGY AGENCY, Application of Genetic Engineering and Recombinant DNA Technology in the Development of Genetic Mechanisms for Medfly (Rep. Consultants Mtg Vienna, 1985), IAEA, Vienna, 1985.
- [18] MERRIAM, J., Cambridge University, UK, personal communication.
- [19] PARDUE, M.L., GALL, J.G., in *Methods in Cell Biology* (PRESCOTT, D.M., Ed.), Vol. 10, Academic Press, New York (1975) 1-16.
- [20] BEDO, D.G., Polytene and mitotic chromosome analysis in *Ceratitis capitata* (Dipt.: Tephritida), *Can. J. Genet. Cytol.* **28** (1986) 180.
- [21] ZACHAROPOULOU, A., Cytogenetic analysis and salivary gland chromosome in the medfly, *Ceratitis capitata*, *Genome* **24** (1987) 67.
- [22] ZACHAROPOULOU, A., University of Patras, Greece, personal communication.
- [23] GRELL, E.H., The dose effect of *ma-1+* and *ry+* on xanthine dehydrogenase activity in *Drosophila melanogaster*, *Z. Indukt. Abstamm. Vererb. Leh.* **93** (1962) 371.
- [24] SAUL, S.H., Rosy-like mutant of the Mediterranean fruit fly, *Ceratitis capitata*, and its potential for use in a genetic sexing program, *Ann. Entomol. Soc. Am.* **75** (1982) 619.
- [25] BENDER, W. SPIERER, P., HOGNESS, D.S., Chromosomal walking and jumping to isolate DNA from the *ac* and *rosy* loci and the bithorax complex in *D. melanogaster*, *J. Mol. Biol.* **168** (1983) 17.
- [26] HOUTCHENS, K., et al., "Screening of *Ceratitis capitata* genomic library for the gene encoding XDH", *Fruit Flies of Economic Importance (Proc. Int. Symp. Rome, 1987)* (CAVALLORO, R., Ed.), A.A. Balkema, Rotterdam (in press).
- [27] MALACRIDA, A.R., University of Pavia, Italy, personal communication.
- [28] RINA, M., Institute of Molecular Biology and Biotechnology, Crete, Greece, personal communication.
- [29] HANDLER, A.M., O'BROCHTA, D.A., "Molecular genetic approaches to genetic sexing", *Fruit Flies of Economic Importance (Proc. Int. Symp. Rome, 1987)* (CAVALLORO, R., Ed.), A.A. Balkema, Rotterdam (in press).
- [30] ROBINSON, A.S., VAN HEEMERT, C., Genetic sexing in *Drosophila melanogaster* using the ADH locus and a Y-linked translocation, *Theor. Appl. Genet.* **59** (1981) 23.
- [31] RIVA, M.E., ROBINSON, A.S., Induction of alcohol dehydrogenase null mutants in the Mediterranean fruit fly, *Ceratitis capitata*, *Biochem. Genet.* **24** (1986) 765.
- [32] GASPERI, G., MALACRIDA, A., MILANI, R., ROBINSON, A.S., Unique features of the ADH system in the medfly, *Ceratitis capitata*, *Atti Assoc. Genet. Ital.* (in press).
- [33] SAVAKIS, C., ROBINSON, A.S., Institute of Molecular Biology and Biotechnology, Crete, Greece, unpublished data.
- [34] SAUL, S.H., University of Hawaii, personal communication.
- [35] KAFATOS, F.C., et al., Studies on the developmentally regulated expression and amplification of insect chorion genes, *Cold Spring Harbor Symp. Quant. Biol.* **L** (1985) 537-549.

- [36] KOMITOPOULOU, K., Institute of Molecular Biology and Biotechnology Crete, Greece, personal communication.
- [37] STEPHANOU, G., ALAHIOTIS, S.N.M., MARMARAS, V.J., CHRISTODOULOU, C., Heat shock response in *Ceratitis capitata*, *Comp. Biochem. Physiol.* **74B** (1983) 425.
- [38] OPPENORTH, F.J., "Biochemistry and genetics of insecticide resistance", *Comprehensive Insect Physiology, Biochemistry and Pharmacology* (KERKUT, G.A., GILBERT, L.I., Eds), Vol. 12, Pergamon Press, Oxford (1986).
- [39] HALL, L.M.C., SPIERER, P., The *Ac* locus of *Drosophila melanogaster*: structural genes for acetylcholinesterase with an unusual 5' leader, *EMBO J.* **5** (1986) 2949.
- [40] KIDWELL, M.G., "Intraspecific hybrid sterility", *The Genetics and Biology of Drosophila* (ASHBURNER, M., CARSON, H.L., THOMPSON, J.N., Jr., Eds), Vol. 13c, Academic Press, London (1983) 125-154.
- [41] O'HARE, K., RUBIN, G.M., Structures of P-transposable elements and their sites of insertion and excision in the *Drosophila melanogaster* genome, *Cell* **34** (1983) 25.
- [42] SCARVADA, B., HARTL, D.L., Interspecific DNA transformation in *Drosophila*, *Proc. Natl. Acad. Sci.* **81** (1984) 7515.
- [43] BRENNAN, M.O., ROWAN, R.G., DICKINSON, W.J., Introduction of a functional P-element into the germ line of *Drosophila hawaiiensis*, *Cell* **38** (1984) 147.
- [44] LASKI, F.A., RIO, D.C., RUBIN, G.M., The tissue specificity of *Drosophila* P element transposition is regulated at the level of mRNA splicing, *Cell* **44** (1986) 7.
- [45] STELLER, H., PIROTTA, V., A transposable P vector that confers selectable G418 resistance to *Drosophila* larvae, *EMBO J.* **5** 4 (1985) 167.
- [46] MOSES, K., University of California, Berkeley, personal communication.
- [47] SAUL, S.H., University of Hawaii, personal communication.
- [48] McINNIS, D.O., et al., IAEA-SM-301/28, these Proceedings.
- [49] MILLER, L.H., et al., Stable integration and expression of a bacterial gene in the *Anopheles gambiae*, *Science* **237** (1987) 779.
- [50] MCGINNIS, W., SHERMDEN, A.W., BECKENDORF, S.K., A transposable element inserted just 5' to a *Drosophila* glue gene alters gene expression and chromatin structure, *Cell* **34** (1983) 75.
- [51] ROSENBERG, U.B., PREISS, A., SEIFERT, E., JACKLE, H., KNIPPLE, D.C., Production of phenocopies by Kruppel antisense RNA injection into *Drosophila* embryos, *Nature (London)* **312** (1985) 703.
- [52] CLINE, J.W., "Primary events in the determination of sex in *Drosophila melanogaster*", *Origin and Evolution of Sex* (HALVORSAN, H.O., MONROY, A., Eds), Alan R. Liss, New York (1985) 301-327.
- [53] BOGGS, R.T., et al., Regulation of sexual differentiation in *Drosophila melanogaster* via alternative splicing of RNA from the transformer gene, *Cell* **50** (1987) 489.
- [54] McKEOWN, M., BELOTE, J.M., BAKER, B.S., A molecular analysis of transformer, a gene in *Drosophila melanogaster* that controls female sexual differentiation, *Cell* **48** (1987) 489.
- [55] GRODZICHER, T., WILLIAMS, T., SHARP, P., SAMBROOK, J., Physical mapping of temperature-sensitive mutations of adenoviruses, *Cold Spring Harbor Symp. Quant. Biol.* **39** (1974) 439.
- [56] COLLINS, F.S., et al., Construction of a general human chromosome jumping library with application to cystic fibrosis, *Science* **235** (1987) 1046.
- [57] SAUL, S.H., Diagnosing the heterogametic sex in the Mediterranean fruit fly. The first sex-linked gene, *Ann. Entomol. Soc. Am.* **78** (1985) 198.
- [58] LOUIS, C., SAVAKIS, C., KAFATOS, F., "Possibilities for genetic engineering in insects of economic interest", *Fruit Flies (Proc. 2nd Int. Symp. Colymbari, Crete, 1986)* (ECONOMOPOULOS, A.P., Ed.), Elsevier, Amsterdam (1987) 45-57.

THE MEDITERRANEAN FRUIT FLY: PROGRESS IN DEVELOPING A GENETIC SEXING STRAIN USING GENETIC ENGINEERING METHODOLOGY

D.O. McINNIS, S.Y.T. TAM, C.R. GRACE
Tropical Fruit and Vegetable Research Laboratory,
Agricultural Research Service,
United States Department of Agriculture,
Honolulu, Hawaii

L.J. HEILMANN, J.B. COURTRIGHT, A.K. KUMARAN
Department of Biology,
Marquette University,
Milwaukee, Wisconsin
United States of America

Abstract

THE MEDITERRANEAN FRUIT FLY: PROGRESS IN DEVELOPING A GENETIC SEXING STRAIN USING GENETIC ENGINEERING METHODOLOGY.

Genetic transformation of the Mediterranean fruit fly (medfly), *Ceratitis capitata* (Wiedemann), has been attempted by micro-injection of foreign DNA into young embryos. The goal of this research is to create a novel medfly strain which incorporates and expresses a foreign gene for resistance to the antibiotic neomycin (geneticin). Ultimately, the goal is to link neomycin resistance to the male sex so as to produce a highly desired males-only strain suitable for sterile insect technique programmes. *Drosophila* P-elements containing the resistance gene coupled to a heat shock promoter were micro-injected into embryos and then assayed for biological activity in subsequent generations. Several modifications of the standard *D. melanogaster* micro-injection procedure were implemented, including the use of chorionated eggs. We have micro-injected over 17 000 medfly embryos with no evidence of genomic transformation. Several lines have shown various levels of tolerance to neomycin above the controls, yet all of these lines have gradually or rapidly lost tolerance to neomycin over time. The possibility of P-element transmission extrachromosomally is currently being investigated.

1. INTRODUCTION

The development of an efficient and economical genetic sexing system for the Mediterranean fruit fly (medfly), *Ceratitis capitata* (Wiedemann), remains an elusive, yet highly desired, goal. To date, the only practical medfly sexing strains capable of mass production are based on pupal colour [1], but these have the major disadvantages of not saving on larval rearing costs, in addition to being partially sterile owing to genetic translocations. The advent of genetic engineering technology

has ushered in potentially powerful new technologies capable of creating highly competitive mass production strains for artificial control (e.g. the sterile insect technique (SIT)) of many insect pest species [2, 3].

In particular, worldwide research over the last two years has focused on the development of a medfly genetic sexing strain by means of genomic transformation using *Drosophila* P-elements [4]. Specifically, plasmids containing P-elements enclosing a bacterial gene which codes for resistance to the antibiotic neomycin (geneticin) are being injected into young medfly embryos. It is hoped that an active neomycin resistance gene will insert itself into the male Y-chromosome directly in order that only males survive in larval diets containing neomycin. However, because the Y-chromosome is small (c. 5% of the total genome) and largely heterochromatic [5], P-element insertion might not occur into the Y-chromosome. In such an event, the resistance gene could then be translocated to the Y-chromosome, creating, however, a less desirable (partially sterile) product. Though the probability of a successful transformation is probably low and results to date are not encouraging, the stakes are high, justifying a continued strong effort, including both biotechnological and classical genetics approaches.

2. MATERIALS AND METHODS

The medfly strains used in these experiments were the standard laboratory strain under mass production for more than two hundred generations, a recently colonized wild strain from Kula, Maui, Hawaii, and a recently imported pupal colour sexing strain [1]. All three of these strains provided eggs which were micro-injected with *Drosophila* plasmid DNA. The structural gene plasmid we used, pUCHsneo, was developed by Steller and Pirrotta [4]. Helper plasmid DNA (provided by courtesy of G. Rubin), which provides the transposase necessary for transposition in *Drosophila*, consisted of *phs* π (November 1985–May 1987), then both *phs* π and *p* π 25.7wc Δ 2–3 (May 1987–present). The structural gene plasmid was co-precipitated with helper plasmid and resuspended in injection buffer (5mM KCL, 0.1mM sodium phosphate, pH6.8) to a final concentration of 500 μ g/mL of structural gene transposon and 100 μ g/mL of helper DNA. The structural gene, actually bacterial in origin, codes for the inactivation of neomycin (Geneticin G418, Sigma Co.) following phosphotransferase activity.

Before micro-injections began, a standard bioassay procedure was developed to screen the control and selected lines on neomycin diet. Egg treatments proved fruitless as eggs were impervious to even very high (> 10 000 ppm) concentrations of neomycin. Newly hatched larvae became susceptible to much lower concentrations of neomycin in larval diets as soon as they started feeding. Depending on the method used to mix the neomycin into the wheat based diet, (lethal dose) LD 99+ concentrations for the standard laboratory strain were c. 1000 ppm (for 10 min of hand mixing), c. 500 ppm (for 10 min of electric blending) and c. 250 ppm (for 10 min

of impact blending). The 500 ppm weight/weight–electric blender method was adopted for convenience and to avoid the slightly deleterious effects on diet consistency resulting from the use of an impact blender.

Micro-injection procedures, with some modifications to suit the medfly, are as described for *Drosophila melanogaster* by Steller and Pirrotta [4]. One important change was the use of chorionated eggs instead of dechorionated ones for injection. Preliminary tests indicated that micro-injected medfly embryos, which had been dechorionated either by hand or with chlorox (5% sodium hypochlorite), hatched at close to normal rates, but yielded very few pupae. Unpunctured, yet dechorionated, embryos hatched and pupated normally, suggesting that only the combination of dechorionation plus puncturing was detrimental, not either process alone. Interestingly, the recent precedent setting case of the genetic transformation of the mosquito, *Anopheles gambiae*, with the pUCHsneo transposon involved chorionated eggs as well [6]. Preliminary embryological studies, following the lead in tephritids set by Anderson [7], indicated that pole cell nuclei formed at c. 3 h of age. Thus, embryo punctures were carried out on 3–4 h old eggs. Embryos were desiccated slightly (1–2 h ambient exposure depending on strain), then punctured with glass needles (tips < 2 in diameter) using a micromanipulator and stereomicroscope (32X). Eggs were covered with inert Halocarbon 700® oil immediately following injection and placed on moist filter paper inside a Petri dish to prevent desiccation. Hatched larvae were transferred to a normal diet and the procedure continued as follows below. The designations 'neo' and 'HI LAB' represent neomycin and the standard, susceptible Hawaii laboratory strain, respectively. Heat shocks, after the G₀ generation, were carried out three times during the larval stage at 37°C for 1 h:

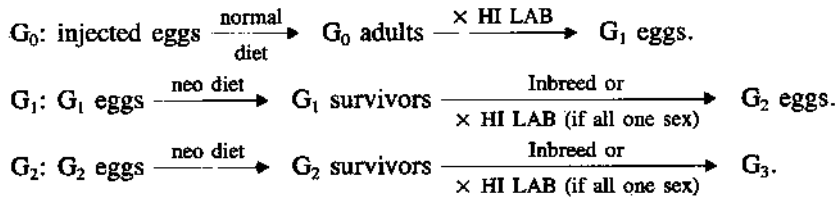

Controls for each new batch of neomycin diet (500 ppm) were run routinely using the susceptible laboratory (HI LAB) strain. Lines which survived to the G₃ strain were evaluated in a standard dose test with neomycin concentrations at 0, 100, 200, 300, 400 and 500 ppm. Survivors at each dose were compared with the controls to assess the degree of resistance or tolerance. Several resistant lines were checked (in A.K. Kumaran's laboratory) for genomic transformation using standard molecular techniques of DNA extraction and hybridization between the labelled P-element probe and the medfly genome. The stock numbers of these selected lines were expanded by rearing on a normal diet and, whenever possible, part of each line was maintained on a selective neomycin diet.

3. RESULTS AND DISCUSSION

By 21 August 1987, over 15 000 medfly embryos in the G_0 generation had been micro-injected (Table I). The percentage of punctured eggs which hatched improved gradually until March 1987, then rose dramatically afterwards, due principally to a subtle change in reducing pre-puncture egg desiccation. Average egg hatch rose from c. 5% to c. 20% after March 1987. Variation in egg hatch rate continued to vary widely, however, between 10–45% for separate cohorts. As noted in Table I, over 500 G_0 pupae have been collected and over 400 G_0 adults emerged. Of the latter, 353 survived to be out-crossed with HI LAB flies of the opposite sex and then 'egged' (Table II). Nearly all of those egged produced hatched larvae and 93 (or 26%) lines yielded some pupae on the selective neomycin diet. The average yield was c. 2% in the G_1 generation. Larval development was typically delayed 1–3 d compared with larvae on a normal diet and adult emergence was considerably reduced from normal rates (c. 95% down to 49%).

Of the 81 lines reaching the G_1 adult stage, 72 survived to be mated and egged for the G_2 generation (Table II). Of these, 38 (or 53%) yielded pupae — a value twice that for the G_1 generation and four times that for controls. Pupal yield also rose dramatically to a level, on average, of five times that of the controls. Apparently, some increased tolerance to neomycin was transmitted from the G_1 survivors to their progeny. Similar improvements were realized in the numbers of G_2 lines providing adults and in emergence rates. In the G_3 generation, or the third cycle on selective media, some further improvement was realized in the proportion of egged G_2 adults (31) reaching the pupal stage (24, i.e. 74%).

The first three lines which had survived three cycles on a neomycin diet were then expanded for two cycles on a normal diet and evaluated in standard neomycin

TABLE I. FIRST GENERATION (G_0) RESULTS FROM MICRO-INJECTING YOUNG EMBRYOS OF *C. capitata* WITH *Drosophila* P-ELEMENTS (HONOLULU, HAWAII)

Time period	No. of eggs injected	No. of eggs hatched	No. of pupae	No. of adults
22 Nov. 1985–20 Mar. 1987	12 218	684 (0.053)	283 (0.023)	223 (0.018)
20 Mar. 1987–21 Aug. 1987	3 446	674 (0.196)	231 (0.067)	179 (0.052)
<i>Totals</i>	15 664	1322 (0.084)	514 (0.033)	402 (0.025)

Note: Numbers in parentheses in each row represent the number of eggs (hatched), pupae or adults as proportions of the number of eggs injected.

TABLE II. SURVIVAL OF *C. capitata* LINES TREATED WITH 500 ppm NEOMYCIN IN A LARVAL DIET AFTER ONE, TWO OR THREE GENERATIONS (G₁, G₂, OR G₃) (HONOLULU, HAWAII)

Generation	Total No. of lines ^a	No. of lines to pupal stage		No. of lines to adult stage	
		No. (prop.)	Av. yield ^b (±SE)	No. (prop.)	Av. emergence ^c (±SE)
G ₁	353	93 (0.26)	0.021 (±0.005)	81 (0.23)	0.49 (±0.041)
G ₂	72	38 (0.53)	0.10 (±0.015)	36 (0.50)	0.71 (±0.025)
G ₃	31	23 (0.74)	0.11 (±0.020)	23 (0.74)	0.66 (±0.045)
Controls ^d	60	7 (0.12)	0.021 (±0.025)	6 (0.10)	0.55 (±0.18)

^a Number of family lines surviving to be mated (3 d old) and egged (5 d old).

^b For lines giving 30 or more eggs, computation is by the average of the number of pupae/the number of eggs hatched.

^c For lines giving five or more pupae, computation is by the average of the number of adults/the number of pupae.

^d Each group consisting of 100 eggs from a susceptible laboratory strain on a standard 10 g of 500 ppm neomycin diet.

dose tests. The latter indicated at least severalfold better survival of these lines at each neomycin dose compared with the controls. Thus, in May 1987, we evaluated these three lines for genomic transformation in high molecular weight DNA. No evidence of transformation could be found, suggesting that the resistance/tolerance we had observed was either already inherent in the medfly strains, or the P-elements were present as extrachromosomal, low molecular weight DNA plasmids. We have since observed that all G₃ selected lines have eventually decreased their tolerance to neomycin, sometimes very rapidly, i.e. in one generation. This behaviour tends to rule out natural, inherent resistance in the medfly as a possible explanation. At this time we are focusing on the possibility that neomycin resistance may be transmitted extrachromosomally, then lost either accidentally or due to lack of selective pressure (i.e. rearing on a normal diet). In comparisons between lines reared for one or more cycles on a normal diet and subcultures of the same lines reared continuously on neomycin diet, we have generally observed significantly greater yields from the cultures raised continuously on neomycin. However, the variation present in these comparisons is great so any conclusion would be premature at this time.

In summation, we have uncovered levels of tolerance to neomycin that are significantly above those of the control group in several selected medfly lines, but, as yet, there is no evidence of genomic transformation. The tolerance also does not seem to be present, a priori, in the medfly strains used in this study since the tolerance

observed has invariably faded after peaking in the G₂ and G₃ generations. We will continue searching for an adequate explanation for the data, as well as attempt to achieve genomic transformation using either different P-element markers or non-P-element vectors. It is encouraging to note the recent success with genomic transformation in *Anopheles gambiae*, in fact using the very same P-element transposon and helper DNA as we have used [7]. However, it would appear that genomic insertion of the neomycin resistance gene was independent of P-elements in the study by Miller and co-workers [6]. Thus, their success further clouds the issue. To date, the efforts elsewhere worldwide to obtain genomic transformation in medflies have also apparently been negative, suggesting that research should begin in earnest in other directions, yet aiming towards the same goal of a genetically engineered medfly sexing strain. We suggest that (1) alternatives to embryo microinjection be examined as a means to transform medfly germ line DNA, and (2) an intensive effort begin to search the medfly genome for P-element homologues or non-homologous transposons.

REFERENCES

- [1] ROBINSON, A.S., VAN HEEMERT, C., *Ceratitis capitata*, a suitable case for genetic sexing, *Genetica* **58** (1982) 229-237.
- [2] RUBIN, G.M., SPRADLING, A.C., Genetic transformation of *Drosophila* with transposable element vectors, *Science* **218** (1982) 348-353.
- [3] ROBINSON, A.S., Sex-ratio manipulation in relation to insect pest control, *Annu. Rev. Genet.* **28** (1983) 191-214.
- [4] STELLER, H., PIRROTTA, V., A transposable P-vector that confers selectable G418 resistance to *Drosophila* larvae, *EMBO J.* **4** (1985) 167-171.
- [5] SOUTHERN, D.I., Cytogenetic observations in *Ceratitis capitata*, *Experientia* **32** (1975) 20-22.
- [6] MILLER, L.H., et al., Stable integration and expression of a bacterial gene in the mosquito, *Anopheles gambiae*, *Science* **237** (1987) 779-781.
- [7] ANDERSON, D.T., The embryology of *Dacus tryoni* (Frogg) [Diptera:Trypetidae (Tephritidae)], the Queensland fruit fly, *J. Embryol. Exp. Morphol.* **10** (1962) 248-292.

GENIE GENETIQUE CHEZ LES INSECTES: CLONAGE ET TRANSGENOSE DE GENES DE RESISTANCE AUX INSECTICIDES

C. MOUCHES

Institut national de la recherche agronomique,
Antibes, France

Abstract-Résumé

GENETIC ENGINEERING IN INSECTS: CLONING AND TRANSFORMATION OF GENES CONFERRING RESISTANCE TO INSECTICIDES.

Genetic engineering and transformation offer the possibility of modifying the genetic material of insects. These techniques will make it possible, for example, to transfer genes conferring resistance to insecticides into the genome of beneficial species, or to develop new methods of combating insect pests and disease carrying insects. We cloned two genes which contain the code for proteins that detoxify insecticides. The first, esterase B1 from *Culex quinquefasciatus*, is amplified approximately 250 times in Californian mosquitoes resistant to organic phosphate insecticides. A second esterase gene was cloned from bacteria which break down various organic phosphates. Experiments are in progress to transfer these genes to *Drosophila* and beneficial insects. These same genes could also serve as selection markers for the purpose of developing transformation techniques for different insects whose genome one wishes to modify using genetic engineering techniques.

GENIE GENETIQUE CHEZ LES INSECTES: CLONAGE ET TRANSGENOSE DE GENES DE RESISTANCE AUX INSECTICIDES.

Le génie génétique et la transgénèse offrent la possibilité de modifier le patrimoine génétique des insectes. Ces techniques permettront par exemple de transférer des gènes de résistance aux insecticides dans le génome des espèces auxiliaires ou de mettre au point des méthodes de lutte nouvelles contre les insectes ravageurs ou vecteurs de maladies. Nous avons cloné deux gènes codant des protéines détoxifiant les insecticides. Le premier, celui de l'estérase B1 de *Culex quinquefasciatus*, est amplifié environ 250 fois chez les moustiques de Californie résistants aux insecticides organophosphorés. Un second gène d'estérase a été cloné à partir de bactéries qui dégradent de nombreux organophosphates. Des expériences sont en cours pour transférer ces gènes à la drosophile et aux insectes auxiliaires. Ces mêmes gènes pourront servir également de marqueurs de sélection pour mettre au point la transgénèse chez les différents insectes dont on veut modifier le génome par les techniques du génie génétique.

1. INTRODUCTION

La possibilité de modifier le patrimoine génétique des insectes d'importance agronomique ou médicale par les techniques modernes du génie génétique et de la transgénèse présente d'abord un intérêt au niveau fondamental. En effet, l'introduction d'éléments mobiles dans la lignée germinale de la drosophile et de certains autres organismes a permis de muter, puis d'isoler, des gènes codant des fonctions importantes difficiles à étudier par les approches traditionnelles. Cette mutagenèse par transposons est un outil moléculaire indispensable pour cloner les gènes impliqués

chez les insectes dans les phénomènes complexes d'adaptation, certaines propriétés physiologiques particulières comme la diapause, la vexion d'agents pathogènes ou encore les phénomènes d'apprentissage et comportementaux.

En outre, la transgénose permettra l'amélioration génétique des insectes auxiliaires et la mise au point de nouvelles techniques de lutte contre les espèces nuisibles. Elle servira par exemple à transférer aux pollinisateurs et aux entomophages des gènes de résistance à des facteurs environnementaux défavorables comme les insecticides chimiques, le froid, la sécheresse ou des maladies. Certaines propriétés physiologiques de ces espèces, comme la faculté d'entrer en diapause, pourront être modifiées par la même technique. Chez les insectes ravageurs ou vecteurs de maladies, la transgénose permettra d'introduire des informations génétique défavorables, responsables au niveau des populations naturelles de stérilités femelles, de phénomènes d'incompatibilité et de dysgénésies, ou modifiant le rapport des sexes. D'autres gènes, nocifs pour les parasites véhiculés, seront transférés aux vecteurs: la transgénose du gène d'une diphénoloxydase dans les anophèles les rendrait incapables de véhiculer l'agent de la malaria. Enfin, les méthodes de luttés génétiques par lâchers inondatifs d'insectes mâles stériles (moustiques, cératites, etc.) pourraient être rendues plus efficaces par la transgénose, chez ces espèces, de gènes permettant le sexage et la stérilisation des individus mâles.

La mise au point de techniques de transgénose efficaces chez ces nombreux insectes implique que l'on dispose de gènes marqueurs aisément sélectionnables. C'est l'une des raisons pour lesquelles nous avons développé un programme de caractérisation et de clonage de gènes codant des protéines détoxifiant les insecticides chimiques. En outre, ces gènes clonés pourront être transférés à différents organismes pour les rendre résistants aux insecticides ou capables de les dégrader: insectes pollinisateurs et entomophages [1], poissons auxiliaires de la lutte contre les moustiques (gambusies), micro-organismes divers, etc.

Enfin, parce qu'ils ont été sélectionnés à une époque récente par d'énormes pressions de sélection, les gènes de résistance aux insecticides sont des marqueurs remarquables pour étudier la dispersion d'une information génétique nouvelle au niveau des populations naturelles et les risques d'un transfert éventuel d'un gène entre espèces différentes.

2. NATURE DES GENES DE RESISTANCE CHOISIS POUR L'OBTENTION D'INSECTES TRANSGENIQUES

Les insecticides les plus utilisés actuellement agissent au niveau du système nerveux des insectes. Les pyréthrinoïdes et les organochlorés modifient la perméabilité ionique de la membrane nerveuse, tandis que les organophosphates et les carbamates inhibent l'acétylcholinestérase. Dans certains cas, les phénomènes de résistance aux insecticides peuvent résulter d'une perméabilité moindre des téguments de l'insecte ou d'une modification de la cible qui présente une moindre affinité

pour le pesticide. Le plus souvent cependant, la résistance résulte de l'augmentation de l'activité d'enzymes de détoxification qui vont neutraliser le pesticide avant qu'il n'atteigne sa cible. Trois catégories d'enzymes sont impliquées dans ce processus: les oxydases, les estérases et les glutathion-transférases.

Dans la mesure où les insectes transgéniques obtenus sont destinés à être relâchés dans l'environnement, il importe de tenir compte des nécessités de protection des écosystèmes. C'est pour cette raison que nous avons délibérément écarté dans notre programme de transgénose l'utilisation de gènes d'insectes codant des protéines cibles insensibles aux insecticides. Dans ce cas, en effet, le risque est grand de voir les insectes résistants obtenus véhiculer, concentrer et introduire des insecticides dans de nouvelles chaînes trophiques. Par contre, ce risque devrait être évité si les gènes transférés codent des enzymes détoxifiant les insecticides. Nous avons récemment cloné deux gènes de ce type, l'un à partir de moustiques *Culex quinquefasciatus* résistants aux organophosphates, l'autre à partir de bactéries dégradant ces produits.

3. CLONAGE D'UN GENE D'ESTERASE RESPONSABLE DE LA RESISTANCE AUX ORGANOPHOSPHATES CHEZ *CULEX QUINQUEFASCIATUS* ET MECANISME DE CETTE RESISTANCE

En collaboration avec les laboratoires de G.P. Georghiou (Université de Californie, à Riverside) et N. Pasteur (CNRS et Université de Montpellier), nous avons caractérisé l'estérase B1 responsable de la résistance aux organophosphates chez les moustiques *C. quinquefasciatus* de Californie. La protéine, constituée d'une seule sous-unité de 67 000 Da, est environ 500 fois plus abondante chez les moustiques résistants que chez les individus sensibles [2]. L'augmentation d'activité détoxifiante responsable de la résistance est donc due à une production accrue de l'enzyme qui représente entre 6 et 12% des protéines totales de l'insecte. Cette accumulation d'estérase B1 résulte d'un processus d'amplification génique [3]: les moustiques résistants contiennent au moins 250 fois plus de copies du gène que les individus sensibles. La structure de l'unité amplifiée est en cours de caractérisation; des résultats préliminaires montrent que le gène de la protéine contient plusieurs introns et qu'il est situé au sein d'une unité amplifiée de plus de 25 Kb. Les séquences co-amplifiées avec le gène de l'estérase B1 contiennent en particulier une structure de type transposon, l'élément «JUAN», qui semble jouer un rôle dans le processus d'amplification.

L'obtention d'insectes résistants aux organophosphates par transgénose du gène de l'estérase B1 implique que la protéine soit synthétisée à un niveau important chez les individus transgéniques. Ce gène devra donc être placé sous le contrôle d'un fort promoteur ou transféré avec la structure responsable de son amplification chez *C. quinquefasciatus*. Les expériences de transgénose dans la drosophile du cADN et du gène de l'estérase B1 et de ses séquences flanquantes sont en cours.

4. CLONAGE DE GENES DE PROTEINES BACTERIENNES DEGRADANT LES INSECTICIDES

De nombreuses bactéries des milieux naturels, en particulier du sol, sont capables de dégrader les insecticides chimiques. C'est le cas de certaines souches de *Pseudomonas diminuta* et de *Flavobacterium* qui contiennent des estérases actives sur un grand nombre d'organosphosphates dont le parathion. Les gènes de ces estérases semblent être portés par des plasmides [4]. Les ADN bactériens ont été digérés partiellement par l'ADNase I et les fragments obtenus, de taille comprise entre 2 et 7 Kb, ont été purifiés par centrifugation en gradient de saccharose. Après addition d'oligonucléotides spécifiques de l'enzyme de restriction Bcl I, ils ont été clonés dans le site Bam HI du plasmide pUC 19. Les bactéries transformées par les plasmides recombinants ont été étalées sur un milieu solide contenant de la pénicilline et du parathion. Plusieurs clones capables de dégrader efficacement le parathion incolore en acide diéthylthiophosphorique et paranitrophénol jaune ont été sélectionnés. La cartographie par des enzymes de restriction et le sous-clonage de leurs plasmides ont permis de localiser les gènes des deux estérases respectives sur un fragment d'ADN d'environ 1,3 Kb. Les expériences d'hybridation croisées montrent que les deux gènes présentent des homologies importantes.

Après addition d'oligonucléotides spécifiques du site Bcl I, les gènes clonés ont été insérés dans le site Bcl I du vecteur de transgénose CosPNéo, entre le promoteur hsp 70 et le gène de résistance à la néomycine portés par ce vecteur [5]. Des drosophiles ont été transformées par les plasmides ainsi construits qui seront également utilisés pour transformer d'autres insectes.

5. DISCUSSION: STRATEGIES FUTURES D'OBTENTION D'INSECTES TRANSGENIQUES RESISTANTS AUX INSECTICIDES

D'autres gènes codant des protéines détoxifiant les insecticides seront disponibles dans un avenir proche. Tous ces gènes seront d'un grand intérêt comme marqueurs pour mettre au point des techniques de transgénose efficaces chez les divers insectes à améliorer.

Cependant, l'utilisation d'insectes transgéniques dans l'environnement exige que l'on réduise les risques d'un éventuel transfert horizontal du gène introduit dans l'espèce améliorée à d'autres organismes de l'écosystème. Ceci implique les conditions suivantes:

- 1) Les vecteurs de gènes utilisés doivent être spécifiques de l'espèce améliorée. Chez la drosophile, l'élément P complet est un bon exemple de ce type de vecteurs puisqu'il ne fonctionne, semble-t-il, que dans la lignée germinale de cette espèce ou d'espèces très voisines. Un élément P dans lequel l'un des introns a été enlevé risque par contre d'être beaucoup moins spécifique, de même qu'un vecteur construit à partir de séquences d'ADN viraux.

2) Les gènes transférés doivent être susceptibles d'être exprimés seulement dans l'espèce transformée. Les gènes de résistance aux insecticides introduits dans les insectes auxiliaires devront être placés sous la dépendance de promoteurs spécifiques de l'espèce améliorée et non pas ubiquistes comme ceux des gènes des protéines de choc thermique («heat-shock protein») ou de virus à large spectre d'hôte. Une autre barrière à l'expression d'un gène dans une espèce hétérologue est la présence dans celui-ci de séquences introniques qui doivent être correctement épissées pour que l'information délivrée soit exacte.

Nous nous proposons donc, à terme, de construire des insectes transgéniques en utilisant des éléments constitutifs de leur génome, réarrangés par les techniques du génie génétique. Des gènes d'enzymes détoxifiant les insecticides seront clonés à partir des espèces à améliorer, par exemple par hybridation hétérologue avec d'autres gènes déjà clonés, comme celui de l'estérase B1 qui s'hybride avec une région du génome de nombreuses espèces d'insectes. Les gènes clonés devront ensuite être placés sous le contrôle d'un fort promoteur ou dans une structure amplifiable spécifiques de l'insecte receveur, puis insérés dans un vecteur approprié construit lui aussi à partir d'éléments du génome de cet insecte.

REFERENCES

- [1] MOUCHES, C., II^e Intern. Symp. Fruit Flies/CRETE (1986) 245.
- [2] MOUCHES, C., et al., Proc. Natl Acad. Sci. USA **84** (1987) 2113.
- [3] MOUCHES, C., et al., Science **233** (1986) 778.
- [4] SEDDAR, C.M., et al., Appl. Environ. Microbiol. **44** (1982) 246.
- [5] STELLER, H., PIROTTA, V., EMBO J. **4** (1985) 167.

COMPETITIVENESS OF IRRADIATED ADULTS OF THE ALMOND MOTH

M.Y.Y. AHMED*, S.A. EL-REFAI**,
E.A. EL-KADY**, Z.A. HASABALLA*

* Radiobiology Department,
Nuclear Research Centre,
Atomic Energy Establishment

** Plant Protection Department,
Faculty of Agriculture,
Ain Shams University
Cairo, Egypt

Abstract

COMPETITIVENESS OF IRRADIATED ADULTS OF THE ALMOND MOTH.

When unmated 24 h old males of *Ephesia cautella* (Walker) were irradiated (I) at 60 krad and confined with unirradiated (U) males and U females (in a 1:1:1 ratio), the infertility of eggs was 45.1%. Increasing the ratio of I:U♂ to 5, 10, 15 and 20 increased the percentage of infertile eggs to 85.7, 92.0, 95.4 and 97.7, respectively. Thus, males treated with a sterilizing dose (60 krad) were fully competitive with U males, especially at the two highest 'flooding' ratios. Males and females treated with a sterilizing dose (60 krad) and confined with U males and U females in a ratio of I♂:I♀:U♂:U♀ caused 60.9% infertility in the resulting eggs. When the ratio of sterile males and females was increased to 5:5:1:1, 10:10:1:1, 15:15:1:1 or 20:20:1:1 (I♂:I♀:U♂:U♀), the percentage of infertility reached 83.5, 97.3, 99.1 and 100.0, respectively. The percentage of actual infertility was less than the expected infertility for the ratios 1:1:1:1, 5:5:1:1, 10:10:1:1 and 15:15:1:1, but it was exceeded by the highest ratio used (20:20:1:1). The competitiveness value for this flooding ratio was 1.00 (i.e. the sterile adults were fully competitive with the normal ones). The results indicated that irradiation at 60 krad, a sterilizing dose, did not decrease the sexual competitiveness of adults. Also, the release of I males only, or of I females together with I males, could give good results in controlling the almond moth population in an autocidal control programme and, therefore, separation of the sexes prior to release is probably unnecessary.

1. INTRODUCTION

The sterile insect release technique shows promise of controlling stored products insects within food commodity storage structures [1]. The degree of competitiveness of irradiated (I) adult insects is of crucial importance in the evaluation of eradication or suppression experiments using the sterile insect release method. If the sterilizing treatment reduces competitiveness, then the number of insects to be released must be increased to effectively attain the 'overflowing' ratio considered necessary to produce a downward trend in the target population. Thus, an evaluation

of the competitiveness of adults having the desired level of sterility is an integral part of research into application of the sterile insect release technique. In this study, the competitiveness of males irradiated at 60 krad¹ — a sterilizing dose — was determined and the effects of releasing sterile females along with the sterile males were evaluated.

2. MATERIALS AND METHODS

Moths were obtained from laboratory stock cultures reared in 3.8 L jars on a diet consisting of 1 kg of crushed wheat, 40 g of yeast and 10 mL of glycerine. Cultures were maintained at $27 \pm 2^\circ\text{C}$ and $70 \pm 5\%$ relative humidity throughout the course of the experiment. Unmated moths were collected in No. 000 gelatin capsules as they emerged, were segregated by sex and aged 24 h before irradiation. Insects were treated in a ⁶⁰Co gamma cell at a dose rate of 30 rad/s.

2.1. Competitiveness value of radiosterilized males

The first test was conducted to determine whether 24 h old *Ephestia cautella* (Walker) adult males, gamma irradiated (I♂) at 60 krad (a sterilizing dose), would compete sexually with unirradiated (U) males. Immediately after eclosion, I♂ were added to the U♂ and then all males were combined with U♀ in ratios of 1:1:1, 5:1:1, 10:1:1, 15:1:1 and 20:1:1 (I♂:U♂:U♀) in inverted 1.9 L jars with screen bottoms. The eggs that fell through the wire mesh were collected in open Petri dishes. One hundred eggs from each 'flooding' ratio were placed in Petri dishes on black construction paper disks and the percentage hatch was determined after seven days (eggs were scored as hatched only if larvae successfully emerged from the chorions). The test was replicated five times. The reader is referred to Fried [2] for the mathematical method of calculating the male competitiveness value.

2.2. Competitiveness value of radiosterilized adults

The second test was set up to investigate the effect on competitiveness, as determined by egg infertility, when I♀ were released along with I♂. Immediately after treatment, the irradiated moths were added to the untreated moths of the same sex and then all males and females were combined. The following ratios were used: 10:10:10:10, 20:20:4:4, 20:20:2:2, 15:15:1:1 and 20:20:1:1. Eggs were collected and handled exactly as before. Each ratio was replicated five times.

The competitiveness of the irradiated adults was determined [3]. In all cases, competitiveness values near 1.0 indicate full competitiveness, those between 0.75 and 1.0 indicate good competitiveness and those greater than 1.0 indicate that irradiated insects are more competitive than unirradiated insects.

¹ 1 rad = 1.00×10^{-2} Gy.

3. RESULTS

The results of the first test were used to calculate the competitiveness value for irradiated males. Irradiated males were caged with U♂ and U♀ at a ratio of 1:1:1 (I♂:U♂:U♀), the percentage of egg infertility increasing from 15.1 in the controls to 45.1. Egg infertility was increased by increasing the ratio of I:U males. For example, it increased to 97.7% by increasing the ratio to 20:1:1. The competitiveness value for this ratio was 1.77. The present results show that males treated with the

TABLE I. COMPETITIVENESS VALUE OF 24 h OLD ADULT *E. cauttella* MALES TREATED AT 60 krad

Ratio (I♂:U♂:U♀)	Percentage of egg infertility	Competitiveness value
0:1:1	15.1	
1:0:1	100.0	
1:1:1	45.1	0.55
5:1:1	85.7	0.99
10:1:1	92.0	0.94
15:1:1	95.4	1.16
20:1:1	97.7	1.77

TABLE II. COMPETITIVENESS VALUE OF RADIOSTERILIZED, 24 h OLD ADULTS OF *E. cauttella* TREATED AT 60 krad

Ratio (I♂:I♀:U♂:U♀)	Percentage of egg infertility			Competitiveness value
	Expected	Corrected expected	Observed	
0:0:1:1	—	—	15.1	
1:1:0:0	—	—	100.0	
1:1:1:1	75.0	77.8	60.9	0.78
5:5:1:1	97.2	97.5	83.5	0.86
10:10:1:1	99.2	99.3	97.3	0.98
15:15:1:1	99.6	99.6	99.1	0.99
20:20:1:1	99.9	99.9	100.0	1.00

sterilizing dose (60 krad) were fully competitive with normal males at all ratios except the lowest one (Table I).

The results of the second test show the effects of irradiation at 60 krad on the mating competitiveness of irradiated males plus irradiated females. When the observed percentage of egg hatch from the 1:1:1:1 (I:I:U:U) experiment was compared with the expected percentage hatch, it was found that the competitiveness value was 0.78.

As the sterile to fertile flooding ratio was increased from 1:1 to 15:1, the percentage of egg infertility increased as expected and the actual percentage of infertility approached the calculated expected percentage of infertility. Thus, the degree of competitiveness of irradiated adults increased with an increasing ratio of irradiated to unirradiated adults. For example, it increased from 0.78 to 1.00 as the ratio increased from 1:1:1:1 to 20:20:1:1 (Table II). The flooding ratio of 20:20:1:1 gave rise to 100.0% infertility in the resulting eggs (the expected infertility was 99.9%) and the competitiveness value was 1.00 (i.e. the sterile adults were fully competitive). Thus, the combined effects of increased infertility and a decrease in the number of adult progeny drastically reduced the reproductive capacity of the population at high flooding ratios.

4. DISCUSSION

The use of egg hatch or egg infertility data for the determination of competitiveness of irradiated insects has a major advantage in that several components of competitiveness are incorporated into this one value [2]. Of course, factors encountered in the field can greatly modify the success of irradiated insects, but it is probably safe to assume that if the treatment debilitates the insects to a point where they are not competitive in the laboratory, then they will not be competitive in the field. If, however, they are fully competitive in laboratory tests, then further field testing is warranted.

The results of our studies show that adult males of the almond moth irradiated with a sterilizing dose (60 krad) were sexually competitive with untreated males at most of the ratios used. In general, the competitiveness that we report for radiosterilized moths agrees with the results obtained for *Spodoptera exigua* (Hübner) treated with gamma radiation (18 krad) [4] and for *Heliothis virescens* (F.) [5].

The effects of releasing both sterile males and females for population suppression were also investigated as there is no practicable method at present for separating by sex very large numbers of *E. cautella*, either in the pupal or adult stages. Our results indicate that the release of sterile females together with sterile males gives excellent results, especially with a flooding ratio of 20:20:1:1, which gave 100.0% infertility in the resulting eggs. The competitiveness values showed that the sterile adults were fully competitive with normal adults at this flooding ratio. The present results agree with those of Husseiny and Madsen [6]. They reported that while the

use of irradiated males or females by themselves gave equivalent control, the use of both sexes together was superior for the navel orange, *Paramylois transitella*, for *S. exigua* sterilized at 18 krad [4], for *H. virescens* [7, 8] and for newly emerged adult *Plodia interpunctella* insects treated at a gamma radiation level of 50 krad [3].

REFERENCES

- [1] BROWER, J.H., in Stored Products Entomology (Proc. Int. Conf. Savannah, Georgia, 1974), United States Department of Agriculture, Washington, DC, p. 167.
- [2] FRIED, M., J. Econ. Entomol. **64** (1971) 869.
- [3] AHMED, M.Y.Y., TILTON, E.W., BROWER, J.H., J. Econ. Entomol. **69** (1976) 349.
- [4] EL-BADRY, E.A., WAKID, A.M., ZAKI, M.M., AHMED, M.Y.Y., Z. Angew. Entomol. **67** (1970) 44.
- [5] WOLFENBARGER, D.A., GUERRA, A.A., J. Econ. Entomol. **65** (1972) 1596.
- [6] HUSSEINY, M.M., MADSEN, H.F., Hilgardia **36** (1964) 113.
- [7] GUERRA, A.A., WOLFENBARGER, D.A., HENDRICKS, D.E., GARCIA, R.D., RAULSTON, J.R., J. Econ. Entomol. **65** (1972) 966.
- [8] GUERRA, A.A., GARCIA, R.D., DE LA ROSA, H.H., J. Econ. Entomol. **65** (1972) 1596.

INSECT REARING AND QUALITY CONTROL
(Session 5)

Chairman

W.J. KLOFT

Federal Republic of Germany

IN VITRO REARING OF *Glossina austeni* Newstead FOR THE STERILE INSECT TECHNIQUE IN TANZANIA

C.S. TARIMO

Tanzania Livestock Research Organization,
Dar es Salaam

F.W. MAKISHE, M.K. GAO

Tsetse and Trypanosomiasis Research Institute,
Tanzania Livestock Research Organization,
Tanga

Tanzania

Abstract

IN VITRO REARING OF *Glossina austeni* Newstead FOR THE STERILE INSECT TECHNIQUE IN TANZANIA.

A colony of *Glossina austeni* Newstead fed in vitro was established in August 1983 at the Tsetse and Trypanosomiasis Research Institute, Tanga, using material from a colony fed in vivo. The rearing room conditions were maintained at $25 \pm 1^\circ\text{C}$ and $75 \pm 5\%$ relative humidity, with dim lighting in the room during the daytime, except during handling and feeding periods. A 12 h scotophase was employed, beginning at 19:00 h. Females were mated when they were three days old with males at least seven to ten days old in a ratio of 1:1 (male:female) and the sexes were separated on day five of the females' adult life. The flies were fed every day, initially on a mixture of fresh/frozen bovine blood and reconstituted lyophilized porcine blood in the ratio of 1:1.5, but the diet was eventually changed to fresh bovine blood following high mortality experienced with the colony. The performance of the colony and the problems experienced are discussed.

1. INTRODUCTION

A colony of *Glossina austeni* Newstead was initiated in September 1982 at the Tsetse and Trypanosomiasis Research Institute, Tanga, with pupae collected in Jozani Forest, Zanzibar. The colony was maintained on rabbits as host animals using the techniques developed by Foster [1] and Nash et al. [2] for *G. austeni* and by Williamson et al. for *G. morsitans morsitans* [3]. The in vitro colony was established with newly emerged flies from the rabbit-fed colony.

2. MATERIALS AND METHODS

The in vitro colony was started in August 1983 by transferring newly emerged flies from the in vivo colony to the membrane feeding system. Each day all of the newly emerged flies from the in vivo colony were transferred to the in vitro system until a colony of 2500 females was attained by the end of October.

The flies were maintained in a room with a constant climate of $25 \pm 1^\circ\text{C}$ and $75 \pm 5\%$ relative humidity. Dim lighting was employed in the room during the daytime, except during handling and feeding periods. A 12 h scotophase was also employed, beginning at 19:00 h [4].

The flies were fed every day, initially on a diet prepared from a mixture of fresh/frozen bovine blood and reconstituted lyophilized porcine blood in the ratio of 1:1.5, but the diet was eventually changed to fresh bovine blood following high mortality experienced within the colony.

2.1. Diet

The diet, prepared from a mixture of fresh/frozen bovine blood and reconstituted lyophilized porcine blood, was processed as shown in Fig. 1. The fresh blood collected from the abattoir was examined for trypanosomes by taking several thick and thin blood smears and examining them microscopically. In addition to the blood examination, flies were dissected and examined for trypanosome infections. This was done to determine if the steps used to prepare the blood would eliminate any viable trypanosomes from the diet.

2.2. Feeding units

The membranes were prepared especially for *G. austeni* and were slightly thinner than those used for feeding *G. m. morsitans* or *G. palpalis*. After feeding, the membranes and feeding trays were washed thoroughly in cold water and then sprayed with distilled water to remove minerals. They were then placed, while still wet, in the oven, where they were heat sterilized overnight.

2.3. Handling of the flies

Females were mated on day three of their adult life with males at least seven to ten days old in a ratio of 1:1 (male:female) and the sexes were separated on day five of the females' adult life. The flies were kept in round PVC cages, each cage holding 15–20 females.

2.4. Data recording

Daily mortality, fecundity/female/week and mean pupal weight were used as parameters for the evaluation of the performance of the colony.

3. RESULTS AND DISCUSSION

The performance of the colony is shown in Table I. As can be seen, the colony's performance was good in 1983 and early 1984, but it experienced high mortality in

7
C
M
L
1983/84

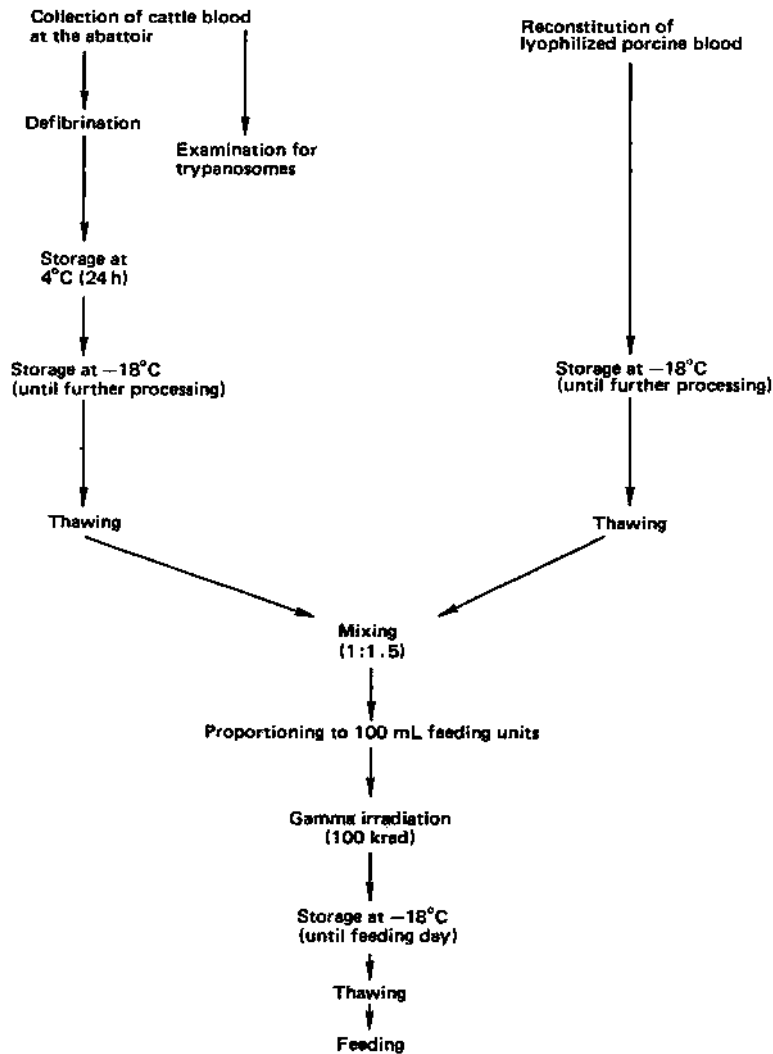

FIG. 1. Preparation of blood. (Note: 1 rad = 1.00×10^{-2} Gy.)

March 1984 and between June and September 1984. The high mortality was due to bacterial contamination of the diet. The colony was fed on freeze dried porcine blood alone in an attempt to lower the mortality rate between July 1984 and January 1985. The mortality rate remained low. In February 1985, the diet was changed to a mixture of fresh/frozen bovine blood and freeze dried porcine blood. High mortality was experienced. In March 1985, chloramphenicol was added to the diet in an attempt to control bacterial contamination. Mortality continued to rise and very low fecundity

TABLE I. PERFORMANCE OF THE IN VITRO *G. austeni* COLONY

Year	Month	Average No. of females	Total No. of pupae produced	Daily ♀ ♀ mortality (%)	Fecundity/ ♀ /week
1983	Sep.	1 531	1 965	0.50	0.072
	Oct.	2 697	4 353	0.90	0.064
	Nov.	3 725	6 596	1.10	0.071
	Dec.	4 092	8 510	1.00	0.077
1984	Jan.	4 231	8 419	0.90	0.070
	Feb.	3 954	7 909	1.00	0.074
	Mar.	4 093	6 065	1.20	0.060
	Apr.	4 116	6 126	0.75	0.051
	May	4 174	5 738	0.59	0.046
	Jun.	3 635	6 173	0.86	0.057
	Jul.	2 708	3 103	2.70	0.037
	Aug.	2 341	2 154	1.36	0.029
	Sep.	2 403	2 748	0.91	0.038
	Oct.	2 590	3 510	0.41	0.044
	Nov.	2 710	3 911	0.48	0.048
	Dec.	2 929	3 712	0.59	0.041
1985	Jan.	2 818	3 621	0.68	0.041
	Feb.	3 080	2 418	1.00	0.028
	Mar.	2 619	2 334	1.74	0.028
	Apr.	1 748	637	2.36	0.013
	May	591	65	6.59	—
	Jun.	180	233	—	—
	Jul.	461	399	—	—
	Aug.	779	593	0.42	0.028
	Sep.	642	554	4.57	0.028
	Oct.	1 935	1 721	0.25	0.028
	Nov.	2 575	3 810	0.53	0.049
	Dec.	3 418	4 792	0.59	0.045
1986	Jan.	4 210	5 801	0.65	0.045
	Feb.	4 556	6 117	0.92	0.047
	Mar.	5 124	7 262	0.72	0.046
	Apr.	5 915	8 519	0.50	0.048

TABLE I. (cont.)

Year	Month	Average No. of females	Total No. of pupae produced	Daily ♀♀ mortality (%)	Fecundity/♀/week
	May	7 041	11 162	0.45	0.051
	Jun.	9 448	13 280	0.45	0.035
	Jul.	12 010	17 069	0.41	0.035
	Aug.	15 351	20 659	0.38	0.035
	Sep.	18 797	20 764	0.49	0.028
	Oct.	17 337	21 914	1.23	0.028
	Nov.	19 273	23 210	0.44	0.021
	Dec.	20 788	21 448	0.85	0.028
1987	Jan.	23 227	22 891	0.52	0.021
	Feb.	22 901	17 930	0.68	0.021
	Mar.	23 448	15 326	0.71	0.015
	Apr.	21 412	19 086	0.66	0.020
	May	21 346	22 733	0.95	0.025
	Jun.	22 312	23 309	0.61	0.028
	Jul.	19 077	23 731	0.65	0.023
	Aug.	22 422	26 613	1.02	0.027
	Sep.	22 266	29 295	1.18	0.032

was experienced. Addition of antibiotics was stopped, but the colony did not recover until the diet was changed to fresh bovine blood in September 1985. It is possible that the antibiotics affected the symbiotic bacteria in the gut and, as such, reproduction was disrupted. The colony has performed well on fresh bovine blood from September 1985 until now.

4. CONCLUSION

The results obtained so far indicate that fresh bovine blood can be used to maintain an in vitro colony of *G. austeni* if sterile conditions are maintained within the in vitro system.

REFERENCES

- [1] FOSTER, R., Laboratory colonies of *G. morsitans* Westwood and *G. austeni* Newstead, Parasitology 47 (1957) 361.
- [2] NASH, T.A.M., JORDAN, A.M., BOYLE, J.A., A method of maintaining *Glossina austeni* Newstead singly, and a study of the feeding habits of the female in relation to larviposition and pupal weight, Bull. Entomol. Res. 57 (1967) 327.
- [3] WILLIAMSON, D.L., et al., Integration of insect sterility and insecticides for control of *Glossina morsitans* Westwood in Tanzania. 1. Production of tsetse flies for release, Bull. Entomol. Res. 73 (1983) 259.
- [4] NASH, T.A.M., JORDAN, A.M., BOYLE, J.A., The large-scale rearing of *Glossina austeni* Newstead in the laboratory. IV. The final technique, Ann. Trop. Med. Parasitol. 62 (1968) 336.

DEVELOPMENT OF SYNTHETIC DIETS AND THEIR USE IN STUDIES ON TSETSE FLY NUTRITION

J.P. KABAYO, M. TAHER, H. BARNOR
FAO/IAEA Entomology Unit,
IAEA Seibersdorf Laboratory,
Vienna

Abstract

DEVELOPMENT OF SYNTHETIC DIETS AND THEIR USE IN STUDIES ON TSETSE FLY NUTRITION.

Synthetic diets recently developed for tsetse flies are being used to gain further understanding of the dietary requirements of blood feeding arthropods. Being simple and relatively determinate in composition as compared with whole blood, synthetic diets can be altered specifically in composition and the effects of such treatments on the nutritional quality can be unambiguously related to particular components of the diet.

Tsetse flies are obligatory blood feeders and rearing them has so far involved the use of a variety of host animal species [1] or the introduction of blood through suitable types of membranes [2, 3]. The various economic, logistical and nutritional quality problems which are associated with these diets [1-8] have prompted research efforts aimed at developing a diet that supports optimal nutrition, is cheap, easy to store, convenient to use and consistent in composition to facilitate standardization of nutritional quality. Such artificial diets have been described for many species of insects [9], but none has been reported for tsetse flies nor for any other obligatory haematophagous insect.

The development of a successful diet demands full knowledge of the dietetics and nutritional requirements of the insect. Earlier observations recorded that for most species of *Glossina*, pig blood was superior to cow blood as an in vitro diet [3]. When batches of freeze dried pig and cow blood, whose nutritional value to *Glossina palpalis palpalis* ranged from low to optimum, were analysed for amino acid, triglyceride and cholesterol contents, it was observed that diets of high nutritional quality had a higher amino acid content compared with suboptimal diets [10]. Pig blood had more triglycerides and less cholesterol than cow blood, but there was no correlation between either triglyceride or cholesterol content in the nutritional quality of blood. Other studies showed that serum-free porcine erythrocytes supported reproduction in several species of tsetse fly, whereas serum-free bovine erythrocytes did not [11]. Attempts to identify the nutritionally important constituents of mammalian blood established that commercial preparations of haemoglobin and bovine serum albumin could replace, respectively, the erythrocyte and serum

TABLE I. COMPOSITION OF THE SYNTHETIC DIET

	Quantity
Glucose	0.10 g
NaCl	0.80 g
NaHCO ₃	0.098 g
KCl	0.04 g
CaCl ₂ .2H ₂ O	0.025 g
Adenosinetriphosphate	0.055 g
MgSO ₄ .7H ₂ O	0.02 g
Na ₂ HPO ₄ .12H ₂ O	0.015 g
KH ₂ PO ₄	0.006 g
Haemoglobin	10.0 g
Albumin	4.5 g
Distilled water	100 mL

fractions of bovine blood [12]. On the basis of these observations, synthetic diet mixtures were formulated incorporating commercially obtained individual blood components of proven or assumed nutritional importance to tsetse flies in various concentrations and permutations [13]. The most successful of such diet mixtures, whose composition is shown in Table I, was found to compare favourably with whole blood diets when tested on several species of *Glossina* and *Stomoxys calcitrans*.

The development of a diet of determinate composition was a significant achievement in the concept of in vitro feeding of haematophagous insects. Diet has been used as a tool in more detailed investigations on the nutritional requirements of tsetse flies as a basis for improving inferior diets. Studies on diets are also being extended to include investigations on the nutritional requirements of trypanosomes. In one study [14], removal of dietary serum lipid was equivalent to the complete removal of serum in its effect on the inhibition of trypanosome maturation in the fly.

Because of the microheterogeneity of the two macromolecular ingredients in the synthetic diet (haemoglobin and albumin), further studies were carried out to examine the uniformity of these ingredients from batch to batch. From these studies the influence of the liganded impurities on the nutritional quality of the macromolecular dietary ingredients was inferred. The nutritional value of albumin was found to be associated with its bound lipid ligands [15]. Recently, the nutritional value of haemoglobin was also shown to be linked to substances bound to it [16, 17]. The successful preparation of ultra-pure, lipid-free haemoglobin [18] facilitated studies in which the

nutritional value of the lipid contaminants found in haemoglobin preparations could be demonstrated [17]. A dialysable factor in haemoglobin, previously shown to be important for normal reproduction in the tsetse fly, has recently been shown to have a similar nutritional function in the stable fly and found to be lipid in nature [16]. Analytical experiments comparing the triglyceride and cholesterol contents of the progeny of flies fed whole blood or synthetic diets revealed differences on the basis of which a mechanism of transovarial transmission of nutritional factors was postulated [19]. Investigations on tsetse fly diets have also been undertaken with the aim of delineating nutritional factors which are important for endosymbionts [20]. In these studies, it was observed that in flies fed diets which induced the disappearance of endosymbionts, reproduction did not progress beyond the first reproductive cycle, subsequent cycles being aborted. Successful development of first cycle larva in flies fed suboptimal diets is probably possible because of the initial supply of endosymbionts inherited from the larva's grandmother feeding on a normal diet. The finding that a freshly emerged female fly contains non-diet derived materials acquired from her mother and utilized in the development of her progeny [20] has important implications with regard to the assessment of the quality of both the diet and the fly.

Nutrition involves the 'fate' of nutrients digested out of foodstuffs as well as the physiological and biochemical processes by which these nutrients are transformed into body tissues or energy for all life supporting activities. It is true that the greatest relevance of nutrition research is the development of better diets, but studies on nutrition which lead to a better understanding of the insect as an individual or as a vector of disease may be just as significant.

REFERENCES

- [1] ITARD, J., JORDAN, A.M., "Mass-rearing using animals for feeding", Tsetse: The Future for Biological Methods in Integrated Control (LAIRD, M., Ed.), International Development Research Centre, Ottawa (1977) 125-140.
- [2] BAUER, B., WETZEL, H., A new membrane for feeding *Glossina morsitans* Westw. (Diptera:Glossinidae), Bull. Entomol. Res. 65 (1976) 563-565.
- [3] MEWS, A.R., LANGLEY, P.A., PIMLEY, R.W., FLOOD, M.E.T., Large-scale rearing of tsetse flies (*Glossina* spp.) in the absence of a living host, Bull. Entomol. Res. 67 (1977) 119-128.
- [4] NASH, T.A.M., KERNAGHAN, R.J., WRIGHT, A.I., A method for prevention of skin reactions in goats used for feeding tsetse flies (*Glossina* spp.), Ann. Trop. Med. Parasitol. 59 (1965) 88-91.
- [5] HINTON, M., McCULLOGH, K.G., MEWS, A.R., Amyloidosis in rabbits used to feed tsetse flies (*Glossina* spp.), Vet. Rec. 104 (1979) 483.
- [6] PARKER, K.R., Some effects of uninfected lab-reared tsetse flies on host rabbits, Acta Trop. 35 (1978) 345-347.
- [7] PARKER, K.R., GOODING, R.H., Effects of host anaemia, local skin factors and circulating antibodies upon biology of laboratory reared *Glossina morsitans* Westw. (Diptera:Glossinidae), Can. J. Zool. 57 (1979) 2393-2401.

- [8] SAUNDERS, D.S., Reproductive abnormalities in the tsetse fly, *Glossina morsitans*, caused by a maternally acting toxicant in rabbit food, *Bull. Entomol. Res.* **60** (1971) 431-438.
- [9] VANDERSANT, E.S., Development, significance and application of artificial diets for insects, *Annu. Rev. Entomol.* **19** (1974) 139-160.
- [10] KABAYO, J.P., DELOACH, J.R., SPATES, G.E., HOLMAN, G.M., KAPATSA, G.M., Studies on the biochemical basis of the nutritional quality of tsetse fly diets, *Comp. Biochem. Physiol.* **83A** (1986) 133-139.
- [11] KABAYO, J.P., Dietetics of *G. morsitans*, *Trans. R. Soc. Trop. Med. Hyg.* **74** (1979) 277-278.
- [12] KABAYO, J.P., LANGLEY, P.A., The nutritional importance of dietary blood components for reproduction in the tsetse fly, *Glossina morsitans*, *J. Insect Physiol.* **31** (1985) 619-624.
- [13] KABAYO, J.P., TAHER, M., VAN DER VLOEDT, A.M., Development of a synthetic diet for *Glossina* (Diptera:Glossinidae), *Bull. Entomol. Res.* **31** (1985) 635-640.
- [14] MAUDLIN, I., KABAYO, J.P., FLOOD, M.E.T., EVANS, D.A., Serum factors and the maturation of *Trypanosoma congolense* infections in *Glossina morsitans*, *Z. Parasitenkd.* **70** (1984) 11-19.
- [15] KABAYO, J.P., The nature of the nutritional importance of serum albumin to *Glossina morsitans*, *J. Insect Physiol.* **28** (1982) 917-923.
- [16] KABAYO, J.P., SPATES, G.E., KAPATSA, G.M., DELOACH, J.R., Lipid nature of dialysable nutritional factor important for normal reproduction in *Glossina palpalis palpalis* and *Stomoxys calcitrans* (in preparation).
- [17] KAPATSA, G.M., KABAYO, J.P., SPATES, G.E., SHEFFIELD, C.L., DELOACH, J.R., Use of lipid-free haemoglobin to demonstrate the nutritional essentiality of erythrocyte stroma lipids for *G. p. palpalis* and *Stomoxys calcitrans* (in preparation).
- [18] DELOACH, J.R., SHEFFIELD, C.L., SPATES, G.E., A continuous flow high yield process for preparation of lipid-free haemoglobin, *Anal. Biochem.* **157** (1986) 191-198.
- [19] KABAYO, J.P., SPATES, G.E., KAPATSA, G.M., TAHER, M., DELOACH, J.R., Comparing the lipid content in successive progeny of *G. p. palpalis* fed different diets (in preparation).
- [20] KABAYO, J.P., MAUDLIN, I., TAHER, M., BARNOR, H., Transovarial transmission of nutritional factors in *Glossina* (in preparation).

QUALITY EVALUATION OF THE MASS REARED ASIAN CORN BORER, *Ostrinia furnacalis* Guenée

Darong ZHOU, Zhenying WANG,
Institute of Plant Protection,
Chinese Academy of Agricultural Sciences,
Beijing, China

Abstract

QUALITY EVALUATION OF THE MASS REARED ASIAN CORN BORER, *Ostrinia furnacalis* Guenée.

W.D. Guthrie et al. reported that the European corn borer (ECB), *Ostrinia nubilalis* Hübner, mass reared continuously on a meridic diet for over 14 generations, will eventually lose its virulence to susceptible inbred lines of maize. However, the present paper indicates that this is not the case with the Asian corn borer (ACB), *Ostrinia furnacalis* Guenée, when mass reared on a semi-artificial diet developed by the first author. Larvae reared continuously for as many as 26 generations still maintain their ability to cause serious whorl and stalk damage to susceptible maize materials. It cannot be concluded, however, that the diet and rearing technique for ACB are superior to those for ECB unless the two diets are used to rear the two *Ostrinia* species at the same time and under the same rearing conditions.

1. INTRODUCTION

Zhou et al. [1] reported the development of a successful semi-artificial diet formula for mass rearing the Asian corn borer (ACB), *Ostrinia furnacalis* Guenée, which has since been widely accepted by many institutions in China. The ingredients of the diet are: soybean meal, 150 g; corn meal, 190 g; brewer's yeast powder, 90 g; multivitamin glucose, 75 g; ascorbic acid, 5 g; agar, 15 g; sorbic acid, 5 g; formaldehyde, 2 mL; and water, 1450 mL.

During 1985–1986, quality evaluation studies of ACB adults and larvae reared on this diet over different generations were carried out in Beijing. The main criteria to be studied included the flight ability of the moths and the virulence of larvae after the whorls of corn plants were artificially infested with them. The results of the study of flight ability were reported by the authors in 1986 [2]. No significant differences were found in the total distance of flight among F_1 , F_{11} , F_{24} , artificially induced diapausing F_{19} generations and the wild population, either during a 24 h or a 48 h flight mill test. The results from the study on the virulence of larvae are reported in the present paper.

TABLE I. COMPARISON OF THE VIRULENCE OF MASS REARED ACB LARVAE VERSUS WILD ACB (1985 RESULTS)

Population	Mean of leaf feeding ratings
<i>Check</i> (wild)	8.0
F ₃	7.5
F ₄	7.6
F ₅	8.0
F ₆	7.9
F ₁₂	7.3
F ₁₃	7.1
F ₁₄	7.4
F ₁₅	7.3
F ₁₆	7.8

TABLE II. COMPARISON OF THE VIRULENCE OF MASS REARED ACB LARVAE VERSUS WILD ACB (1986 RESULTS)

Population tested	Mean of leaf feeding ratings	
	Zi 330	Zhong-Dan No. 2
<i>Check</i> (wild)	8.7	7.6
F ₁	8.6	7.0
F ₁₃	8.7	7.5
F ₁₅	8.8	7.5
F ₂₆	8.7	7.4
W × F ₂₆	8.8	7.2
F ₂₆ × W	8.5	7.1

TABLE III. COMPARISON OF THE NUMBERS OF HOLES CAUSED BY MASS REARED ACB LARVAE VERSUS WILD ACB (1986 RESULTS)

Population	No. of plants observed	Average No. of holes/plant
<i>Check</i> (wild)	19	2.1
F ₁	20	1.8
F ₁₃	23	2.2
F ₁₅	24	1.9
W × F ₂₅	13	2.0
F ₂₆ × W	16	2.1
F ₂₆	28	1.9

2. MATERIALS AND METHODS

Mass reared ACB cultures, F₁, F₃, F₄, F₅, F₆, F₁₂, F₁₃, F₁₄, F₁₅, F₂₅ and F₂₆ generations, originating from wild populations collected from Hengshui District, Hebei Province, over two successive years, and also hybrids of the wild population cross F₂₆, were used in the testing. All of the cultures were kept under laboratory conditions using the same semi-artificial diet. A single cross, Zhong-Dan No. 2 (susceptible), and an inbred line, Zi 330 (highly susceptible), were used as the test plants, which were planted in late April of 1985 and 1986 in a plot design as described by Guthrie et al. [3]. In order to compare the virulence of different cultures in causing leaf feeding damage, the corn plants were infested with two egg masses/plant in two applications, with an interval of two days, at the mid-whorl stage of plant development, reaching a total infestation level of four egg masses/plant. All plots were rated, on an individual plant basis, according to a nine class leaf feeding rating scale 20 days after infestation. In addition to the damage caused by insects feeding on leaves, the ability to cause holes in stalks among different cultures was compared in 1986. In all experiments, the wild populations were used as the checks.

3. RESULTS AND DISCUSSION

The results comparing the virulence of mass reared ACB larvae of different cultures in causing leaf feeding and stalk damage are given in Tables I-III. The results showed that ACB larvae reared under laboratory conditions on the semi-artificial diet for as many as 15 to 26 generations still maintained their ability to cause

severe damage to susceptible corn plants; in fact, as well as the wild populations and the F₁-F₁₃ cultures. The leaf feeding scores reached as high as 8 and stalk damage averaged about 200 holes/100 plants. It is concluded, therefore, that ACB larvae reared on a semi-artificial diet developed by the first author for over 14 generations can still be used for host plant resistance studies, i.e. their ability to cause serious damage to susceptible corn materials.

4. CONCLUSION

Although Guthrie et al. reported that the European corn borer (ECB), *Ostrinia nubilalis* Hübner, mass reared continuously on a meridic diet for over 14 generations, will eventually lose its virulence to susceptible inbred lines of maize [4], this is not the case with ACB mass reared on the particular semi-artificial diet mentioned earlier. However, this is still a preliminary result and it cannot be concluded that the latter diet is better than the meridic diet reported by Guthrie et al. [5], unless the two diets are used to rear the two *Ostrinia* species at the same time and under the same rearing conditions.

REFERENCES

- [1] ZHOU, Darong, et al., Studies on the mass rearing of corn borer: I. Development of a satisfactory artificial diet for larval growth, *Acta Phytophylacia Sin.* 7 2 (1980) 113-122.
- [2] ZHOU, Darong, WANG, Zhenying, in Proc. 14th Symp. of the Int. Working Group on *Ostrinia*, Beijing, 1986, Chinese Academy of Sciences, Beijing.
- [3] GUTHRIE, W.D., JARVIS, J.L., REED, G.L., LODHOLZ, M.L., Plant damage and survival of European corn borer cultures reared for 16 generations on maize plants and for 120 generations on a meridic diet (one generation per year on resistant or susceptible maize plants, eight generations per year on the diet), *J. Econ. Entomol.* 75 (1982) 134-136.
- [4] GUTHRIE, W.D., et al., European corn borer: Virulence on corn plants of larvae reared for different generations on a meridic diet, *J. Econ. Entomol.* 67 (1974) 605-606.
- [5] GUTHRIE, W.D., RUSSELL, W.A., JENNINGS, C.W., "Resistance of maize to second brood European corn borers", *Proc. Annual Corn and Sorghum Research Conf.*, Vol. 26, 1971, pp. 165-179.

RECENT DEVELOPMENTS IN MEDFLY MASS REARING

A.P. ECONOMOPOULOS, N.D. BRUZZONE, S. JUDT,
V. WORNOAYPORN, M.N. EL-AGAL, A.A. AL-TAWEEL,
Hua-Song WANG
FAO/IAEA Entomology Unit,
IAEA Seibersdorf Laboratory,
Vienna

Abstract

RECENT DEVELOPMENTS IN MEDFLY MASS REARING.

Continuous light in the adult stage increased by 15–20% the number of eggs produced by artificially reared Mediterranean fruit flies (medflies) as compared with a 14:10 h light:dark regime. This increase was not apparent when the flies were kept in high density mass rearing cages because of a steep increase in insect mortality owing to the continuous light. An oviposition net, with hole size similar in diameter to the female's ovipositor, almost doubled the number of eggs produced per female as compared with oviposition nets with large holes. The increased degree of egg 'sticking' observed on the net with small holes was reduced significantly when the net was treated with a lubricant release agent. In a 'starter-finisher' standard IAEA Seibersdorf Laboratory larval diet, sugar could be replaced in the finisher diet with molasses without any adverse effect on the production and quality of flies. In an all-molasses diet, the quantity of molasses could be reduced by 50% in the finisher diet without any substantial effect on insect production or quality. A similar reduction in the quantity of brewer's yeast was possible only with a compensatory increase in the quantity of molasses. The spent finisher larval diet, heat treated to kill the remaining larvae or pupae, could be used for successful second larval production, provided it was mixed again with water and small amounts of sugar, and possibly yeast, and combined with a fresh starter diet. Collection of all larvae within the first 'popping' day by a 'tumbling' machine, and subsequent pupation in wheat bran, resulted in the smallest pupae, but longest living adults, as compared with four day popping and pupation in wheat bran, sand, talc and 'naked' pupation. The latter resulted in a significant decrease in adult survival. Pupal handling procedures for sterile insect technique release reduced both adult emergence and flight ability. The percentage of emergence was substantially reduced by mechanical sorting (to separate female pupae in a white female puparium mutant strain), irradiation, storage at low temperature and packing in airtight plastic bags, while flight ability was affected substantially by fluorescent powder treatment for adult marking and, to a lesser extent, by irradiation and low temperature storage of pupae.

1. INTRODUCTION

To support large field applications of the sterile insect technique (SIT) against the Mediterranean fruit fly (medfly), *Ceratitidis capitata* (Wiedemann), large scale mass rearing operations have been established, e.g. in southern Mexico [1, 2] and Guatemala. Much of the artificial rearing technology used in the above facilities was developed in the course of the medfly project of the FAO/IAEA Entomology Unit

at Seibersdorf. In the last two years, considerable effort in the project was focused on colony conditions and materials affecting egg production and collection, optimization and maximum utilization of larval diet ingredients, techniques and materials for larval collection and pupation and the effect of SIT pupal handling procedures on the quality of flies.

A 500 m² pilot medfly rearing facility had been constructed in 1983 at Seibersdorf to permit large scale research and development. Quality control procedures were applied to large scale rearing [3], certain pupation environments were compared [4] and a 'starter-finisher' larval diet methodology was developed [5]. Also, a preliminary experiment indicated that the spent larval diet can be used for second pupal production [6].

2. GENERAL METHODOLOGY

A medfly colony established in October 1983 from pupae collected from guava in Sohag Governate, Egypt, was used for all of the experiments, described below, that were undertaken between summer 1985 and summer 1987. Adult cages were 2 m × 1.8 m × 0.2 m, 'loaded' with 4.5 L of pupae and 3.5 kg of adult food (sugar:hydrolyzed protein, 3:1). The pupae were kept for two weeks following adult emergence. When the experiments involved small numbers of adults, 11 cm × 11 cm × 15.3 cm plastic cages were used. In all experiments, the sex ratio was always 1:1 at the beginning. For oviposition, the large cages had the two large sides covered with a plastic (Diolen) net. In the small cages, a 9 cm hole in one of the two small sides of the cage was covered with a net for oviposition.

Environmental conditions in the oviposition rooms were kept at 25 ± 2°C and 55–65% relative humidity (RH). Larvae were kept at 29°C and 95% RH for the first three days and 20–22°C and 80% RH for the rest of the time until they 'popped' from the diet trays. Thereafter, they were held at 20°C and 60% RH in a dim red lit room for two more days in order to complete pupation. Pupae were kept at 20–22°C until emergence. For quality control, pupae were sorted into size classes and the percentages of emergence and flight ability were measured [3]. For details related to the specific experiments, refer to the respective sections below.

3. RESULTS AND DISCUSSION

No detailed data are presented. Instead, the overall results are described and discussed.

3.1. Continuous light in the adult colony

One adult colony room was continuously illuminated (LL) with a light intensity inside the cages of about 2800 lux. In a second adult room, light of the same quality

and intensity was maintained for 14 h daily (LD). When the experiment started, the colony had already been under LL for 14 generations. The experiment lasted for eight consecutive generations: LL₁₅₋₂₂ and LD_{p-7} (p = parental generation started from LL₁₅). Both low insect density (one adult per c. 90 cm³ in small cages) and high insect density (one adult per c. 3 cm³ in large cages) were studied. Adult survival was studied at three densities: one adult per 90 cm³, 6 cm³ or 3 cm³ of small cage space. When small cages were used, six replicates were run, whereas with large cages only four replicates were run.

At low insect density, no substantial difference was observed in adult survival between LL and LD during the two week cage life. At high density (one adult/6 cm³), male survival was practically the same in the two regimes, while females survived for a significantly shorter length of time under LL as compared with LD. At the highest density (one adult/3 cm³, which is the case in the standard colony large cage) both males and females survived for a significantly shorter length of time under LL as compared with LD.

In all seven consecutive generations, females under LL produced c. 15-20% more eggs than females under LD (low insect density small cages). Egg 'sticking' on the oviposition net also increased by 20-25% under LL, apparently because the net became dirtier than under LD owing to continuous insect activity. In the large colony cages with high insect density, similar quantities of eggs per cage were collected (eggs which dropped into the water troughs) from both LL and LD in the successive generations. Apparently, the increased mortality and egg sticking on the oviposition net under LL diminished the potential of increased productivity seen at low insect density.

Mating activity was random in time under LL as compared with LD conditions, when matings occurred mostly in the first half of the light phase. No substantial differences were observed in pupal production, adult emergence and flight ability in the two systems (immature stages were always under LD). Finally, selection for insects reproducing at high rates in the first days of the adult stage was better under LL than under LD.

3.2. Oviposition net

Small cages with an insect density of one adult per 62 cm³ were used. In some tests, a density of one insect per 6 cm³ was also used. Diolen oviposition nets of hole size 0.1 mm² and 0.3/1.0 mm² (holes of two different sizes alternated), 0.5/0.6 mm² (as before) and 1.3 mm² and 2.2 mm² were compared. Twice a week, dead insects were removed and recorded and all eggs laid during the day following the mortality check were collected and counted. A 12 h:12 h light:dark regime was maintained in all of the experiments. Five replications were run in each experiment.

The number of eggs per living female per day increased significantly as the size of the oviposition holes decreased. Thus, in the net with the largest holes (2.2 mm²), only 16 eggs per living female per day were produced as compared with

29 eggs in the net with 0.1 mm² holes (hole size similar to the ovipositor's diameter). On the other hand, a significantly higher percentage of eggs were stuck on the small holes net as compared with the large holes net, i.e. 40 versus 16%, respectively. In general, egg production declined with age, while egg sticking on the net increased with age, apparently because the net was becoming increasingly dirty. Egg sticking on the net was reduced impressively when poly-tetra-fluor-ethylene (a lubricant-release agent) was applied on the net. The use of a small holes oviposition net treated with the above agent in high insect density cages did not result in increased mortality as compared with a bigger holes net or an untreated net. Preliminary results from some of the above experiments have already been published [7].

3.3. Larval starter-finisher diet

The IAEA Seibersdorf Laboratory standard larval diet is composed of (in %): wheat bran, 24.2; sugar, 16.2; brewer's yeast, 8.1; citric acid, 0.6; sodium benzoate, 0.5; and water, 50.5 [3]. When the medium is used as a starter diet, the quantity of citric acid is doubled [5]. Two hundred and fifty grams of starter were seeded with 500 48-h old eggs/g and kept at 29°C and 90% RH for two days. Subsequently, the starter was transferred to a tray of 4750 g of finisher diet, kept for an additional day at 29°C and then transferred to 20–22°C and 80% RH until larval popping.

When sugar was replaced in the above diet with molasses from Egypt, pupal production and size and adult emergence and flight ability were reduced by 5–10%, while the duration of the larval stage was extended slightly. On the other hand, when Schwechat brewer's yeast was replaced with yeast from Cairo, Egypt, all production parameters were improved by 5–10%, except the duration of the larval stage, which was extended again. When both molasses and yeast from Egypt were used, all production parameters except pupal size were affected negatively by 5–10%. The use of molasses only in the finisher diet produced results identical with the all-sugar control. When molasses and yeast from Egypt were used in both the starter and finisher diets, it was possible to reduce the quantity of molasses in the finisher diet to 50% of the standard quantity without any negative effect on the production parameters mentioned earlier. The same was not possible with yeast from Egypt unless the quantity of molasses was simultaneously increased in the finished diet. The above results indicate that molasses should be used in a much smaller quantity as compared with the standard quantity of sugar used and that the quantity of yeast can be reduced considerably in the finisher diet provided the quantity of molasses is increased.

3.4. Larval diet recycling

The spent larval diet still contains larvae and pupae which must be killed before disposal. This is usually done either by irradiation or heat treatment. In preliminary experiments, a heat treated spent diet was found to be suitable for second production

of medflies provided it was mixed again with water [6]. Even better results were obtained when the heat treated diet was mixed with water and small quantities of sugar and it was combined with a fresh starter diet [8]. In the present experiments, quantities of about 15 kg of spent diet were autoclaved at 120°C for about 10 min. The temperature inside the diet reached 70–95°C. Subsequently, the diet was mixed with water (c. 35% of final product), or a water solution of various quantities of sugar, brewer's yeast or preservative, or all combined. In all cases, the enriched spent diet was used with a fresh starter.

The addition of water and combination with a fresh starter were found to be essential for good quality second production of medflies. Small quantities of sugar (2 or 4%) increased slightly the percentage of recovery (of hatched eggs to pupae) and pupal size and increased considerably the flight ability of the flies produced. Addition of brewer's yeast at 4% appeared to result in increased adult emergence and flight ability. The addition of preservative, even small quantities, was found to negatively affect pupal production, adult emergence and flight ability.

3.5. Larval pupation

In a first experiment, medfly larvae popping off the larval diet trays for four consecutive days were allowed to pupate either in wheat bran trays or in screen bottom trays ('naked' pupation). In a second experiment, four day larval popping and pupation into wheat bran, Sahara sand, talc powder, a screen bottom tray (naked), with or without air blowing on the larvae, and 'tumbler' collection of all larvae within the first popping day and subsequent pupation into wheat bran were studied and compared.

In the first experiment, naked pupation resulted in no significant differences from wheat bran pupation as far as pupal size, percentage of adult emergence and flight ability were concerned. On the other hand, the survival time of flies that pupated naked was significantly shorter than that of flies that pupated in wheat bran. Both fly types were fed protein adult food. In other studies, adults from pupae without a pupation medium were also found to be shorter lived than those that pupated in a medium [9].

From the second experiment, the following main results were obtained. (1) Pupation in tumbler bran resulted in the smallest pupae size but the highest percentage of survival (adults fed sugar only) of all other methods tested; (2) pupation in Sahara sand resulted in the largest pupae size; (3) pupation in talc resulted in the highest adult emergence but the lowest flight ability; and (4) naked pupation resulted in the lowest rate of adult emergence and survival. When all quality parameters were combined, pupation in tumbler bran seemed to produce the best results (unless the small insect size proves negative for SIT effectiveness [10]), followed by Sahara sand.

3.6. Pupal handling for SIT release

In a recent SIT field experiment, brown male puparia were separated from the white female puparia of a mutant strain reared in Seibersdorf, irradiated, dusted with fluorescent powder for adult marking and shipped in airtight plastic bags to Italy for release [11]. In detail, pupae were separated from the pupation medium (wheat bran) using a blowing machine and synchronized for emergence by storage at 18°C (standard handling temperature of 25°C). Brown male puparia were then separated from white female puparia using a colour sorting machine, irradiated at 9.5 krad¹ of ⁶⁰Co for sterilization, stored overnight at 18°C to slow development, dusted with fluorescent powder for adult marking upon emergence, packed in quantities of about 1 L in airtight plastic bags and shipped by air and car to Italy (shipping time about 27 h). The effect of each successive treatment on emergence and flight ability was studied at two different dates.

The percentage of adult emergence was reduced from c. 90% to c. 45%, while the percentage of flight ability was reduced from c. 80% to c. 20% following the above successive treatments of pupae. Low temperature synchronization of adult emergence, mechanical sorting of brown from white puparia, irradiation and overnight low temperature storage of pupae before marking and shipping to Italy were found to affect adult emergence considerably on both test dates. Separation of wheat bran from pupae by air blowing and packing were found to also affect adult emergence, but only on one of the two test dates. The flight ability of adults was affected adversely by low temperature synchronization of adult emergence, irradiation, low temperature overnight storage and fluorescent powder marking. Similar effects on emergence and flight ability were obtained when control pupae from the 'Sohag' laboratory strain were subjected to the same sequence of treatments. In conclusion, it appears that low temperature and irradiation adversely affected both quality parameters, while separation of white puparia primarily affected emergence and dusting with fluorescent powder primarily affected flight ability.

4. GENERAL CONCLUSIONS

In the mass rearing of the medfly, continuous light in the adult stage does not increase the production of eggs from overcrowded large cages. For increased production of eggs, an oviposition net with holes similar in size to the diameter of the female ovipositor must be used. The net should be treated with a lubricant-release agent to decrease egg sticking.

In a starter-finisher larval diet, molasses can replace sugar in the finisher diet. A considerable reduction in the quantity of molasses in the finisher diet appears possible. The quantity of whole brewer's yeast can also be reduced in the finisher

¹ 1 rad = 1.00 × 10⁻² Gy.

diet if the quantity of molasses is increased to compensate. The spent finisher larval diet can be used for good second production of pupae, provided it is mixed with water and a small quantity of nutrients and used with a fresh starter diet.

Collection of grown larvae on the first popping day using a tumbler machine, and subsequent pupation in wheat bran, gave very good adult emergence and flight ability and an excellent survival rate in spite of the small size of the pupae. Pupation in sand from Sahara gave excellent results as far as pupal size is concerned and good results for adult emergence, flight ability and survival. Naked pupation had an impressive negative effect on adult survival. Various pupal treatments before adult emergence and release in the field appear to affect drastically adult emergence and flight ability. The most serious impact was that of low temperature storage, mechanical agitation (e.g. for separation of sexes with different puparium colour), irradiation and fluorescent powder marking.

ACKNOWLEDGEMENTS

We wish to thank D.A. Lindquist and R.E. Gingrich for supporting this work. We also thank H. Gensthaller, H. Görz and L. Lang for technical help and E. Pereira for typing the manuscript.

REFERENCES

- [1] HENDRICH, J., ORTIZ, G., LIEDO, P., SCHWARZ, A., "Six years of successful medfly program in Mexico and Guatemala", Fruit Flies of Economic Importance (Proc. Int. Symp. Athens, 1982) (CAVALLORO, R., Ed.), A.A. Balkema, Rotterdam (1983) 353.
- [2] SCHWARZ, A.J., ZAMBADA, A., OROZCO, D.H.S., ZAVALA, J.L., CALKINS, C.O., Mass production of the Mediterranean fruit fly at Metapa, Mexico, Fla. Entomol. **68** (1985) 467.
- [3] HOOPER, G.H.S., Application of quality control procedures to large scale rearing of the Mediterranean fruit fly, Entomol. Exp. Appl. **44** (1987) 161.
- [4] HOOPER, G.H.S., Effect of pupation environment on the quality of pupae and adults of the Mediterranean fruit fly, Entomol. Exp. Appl. **44** (1987) 155.
- [5] FAY, H.A.C., A starter diet for mass-rearing larvae of the Mediterranean fruit fly, *Ceratitis capitata* (Wied.), Entomol. Exp. Appl. (in press).
- [6] BRUZZONE, N.D., SCHWARZ-GEHRKE, A.J., Recycling larval rearing medium for Mediterranean fruit fly mass production: A preliminary experiment, J. Appl. Entomol. **103** (1987) 418.
- [7] ECONOMOPOULOS, A.P., JUDT, S., "Effect of oviposition net hole size and treatment of net with sugar solution or lubricant-release agent on medfly egg production and collection", Fruit Flies (Proc. 2nd Int. Symp. Colymbari, Crete, 1986), (ECONOMOPOULOS, A.P., Ed.), Elsevier, Amsterdam (1987) 325.
- [8] BRUZZONE, N.D., "Recycling larval media for mass-rearing the Mediterranean fruit fly", *ibid.*, p. 277.
- [9] VARGAS, R.L., CHANG, H.B.C., KOMURA, M., KAWAMOTO, D.S., Evaluation of two pupation methods for mass production of Mediterranean fruit fly (Diptera:Tephritidae), J. Econ. Entomol. **79** (1986) 864.

- [10] CHURCHILL-STANLAND, C., et al., Size as a factor in the mating propensity of Mediterranean fruit flies *Ceratitis capitata* (Diptera:Tephritidae) in the laboratory, *J. Econ. Entomol.* **79** (1986) 614.
- [11] CIRIO, U., CAPPARELLA, M., ECONOMOPOULOS, A.P., "Control of medfly (*Ceratitis capitata* Wied.) by releasing a mass-reared genetic sexing strain", *Fruit Flies (Proc. 2nd Int. Symp. Colymbari, Crete, 1986)* (ECONOMOPOULOS, A.P., Ed.), Elsevier, Amsterdam (1987) 515.

GAMMA IRRADIATION OF THE MEDITERRANEAN FRUIT FLY (*Ceratitis capitata* Wied.): EMERGENCE, LONGEVITY, STERILITY AND SEXUAL COMPETITIVENESS AFTER TREATMENT IN AIR AND PARTIAL NITROGEN

A. ZÜMREOĞLU, K. AKMAN
Plant Protection Research Institute,
Bornova, Izmir,
Turkey

Abstract

GAMMA IRRADIATION OF THE MEDITERRANEAN FRUIT FLY (*Ceratitis capitata* Wied.): EMERGENCE, LONGEVITY, STERILITY AND SEXUAL COMPETITIVENESS AFTER TREATMENT IN AIR AND PARTIAL NITROGEN.

When the pupae of the Mediterranean fruit fly (medfly) (*Ceratitis capitata* Wiedemann) were irradiated in air at radiation doses of 9, 10 and 11 krad one and two days before adult eclosion, the level of sterility in the males increased with the increasing doses of radiation. However, emergence, longevity and sexual competitiveness of the males decreased at higher dose levels. The male pupae, which were irradiated in partial nitrogen at 14 krad of gamma radiation, were more competitive when compared with male pupae irradiated in air at lower doses of gamma radiation.

1. INTRODUCTION

The use of irradiation to sterilize various insect species is the basis of the sterile insect technique (SIT) for control or eradication of insects. The radiosterilization of the Mediterranean fruit fly (medfly) (*Ceratitis capitata* Wiedemann) has been studied and described by many researchers [1-7]. Although gamma irradiation doses of 9-10 krad¹ applied to mature pupae in air produced very high levels of sterility in males, some researchers indicated that irradiation of medfly pupae in air could severely affect the sexual competitiveness of males [8, 4]. They therefore suggested that irradiation of pupae in nitrogen might be a way to avoid some of the problems involved in a large scale sterile insect release programme if this treatment would increase the sexual competitiveness of the resulting adults. The advantage of irradiation in nitrogen is generally believed to result from a lowering of oxygen tension, which reduces free radical and peroxide formation in cells exposed to irradiation [9, 10]. Taking this point into consideration as well, an experiment was

¹ 1 rad = 1.00×10^{-2} Gy.

designed to explore the dose-sterility relationship of irradiation in atmosphere and to compare the sexual competitiveness of male pupae at doses of 9, 10, 11 and 14 krad (in partial nitrogen). Data also were obtained on the emergence and longevity of both sexes.

2. MATERIALS AND METHODS

A total of 1000 mL (c. 65 000) of eight and nine day old (one to two days before adult eclosion) test pupae were obtained from the mass production section of our laboratory where larvae were reared on a diet based on wheat bran [11]. Adults held in standard cages were provided with food and water.

Irradiation was carried out in a 5000 Ci cobalt-60 irradiator at a dose rate c. 1 krad/min at the Middle East Technical University, Ankara.² Equal amounts of pupae (100 mL each) were placed in polypropylene vials and were irradiated with doses of 9, 10 and 11 krad in atmosphere and 14 krad in partial nitrogen. For irradiation of pupae in nitrogen, the pupae in vials were flushed with high purity nitrogen at a rate of 5 L/min before treatment. Since it was impossible to continue nitrogen flushing during irradiation, the medium was assumed to be partial nitrogen instead of full nitrogen. Emergence and longevity of the irradiated insects were determined by placing random samples of 100 pupae from each treatment in paper bags and 1 L capacity polystyrene cages. Actual emergence was checked three days after the expected date of emergence. The mortality of flies was checked weekly for three weeks and at the end of the sixth week, when the test ended. These tests were replicated three times.

To determine the level of sterility of the males, 25 treated males were paired with 25 untreated females in 1 L capacity polystyrene cages. The numbers of eggs laid were determined twice weekly for four weeks and c. 150-200 eggs from each replication in each collection were placed on moist blotting paper in a Petri dish. Hatching was scored after three days. The mortality of adults was checked prior to the placing of egg receptacles in the cages. The level of sterility was determined according to the percentage of hatching of the collected eggs. This test was replicated five times.

In another study, to evaluate sexual competitiveness, a ratio of 3:1:1 (reproductive success) was used [2]. For this purpose, 45 irradiated males:15 normal males:15 normal females were placed in 28 cm × 30 cm × 40 cm screen cages one day after emergence. The number of eggs laid and the percentage of hatching were determined twice a week for four weeks. The competitiveness values (CV) for the irradiated males were calculated according to Fried's parameters, as follows [12]:

$$CV = \frac{\text{Per cent mean egg hatch in control males} - \text{per cent mean egg hatch in treated males}}{\text{Per cent mean egg hatch in treated males} - \text{per cent sterility in treated males}} : \text{ratio}$$

² 1 curie (Ci) = 3.70×10^{10} Bq.

3. RESULTS AND DISCUSSION

Tables I and II give data on the effects of irradiation on emergence and longevity. According to the tables, there were no significant differences between treatments for adult emergence. Data on mortality after three and four weeks suggested that pupae treated with higher radiation doses had higher mortality among adults. However, the highest dose applied (14 krad in nitrogen) gave the lowest mortality,

TABLE I. EFFECT OF GAMMA IRRADIATION ON THE EMERGENCE AND LONGEVITY OF MEDFLY PUPAE IRRADIATED AT 9, 10 AND 14 krad TWO DAYS BEFORE ADULT ECLOSION

Treatment	Per cent emergence	Per cent mortality			
		Male	Female	Total ^a	Total ^b
9 krad	77	33	17	50	90
10 krad	75	41	21	62	94
14 krad (partial nitrogen)	83	29	15	44	89
<i>Control</i>	87	19	16	35	84

^a Three weeks of data, with three replications.

^b Six weeks of data on males and females.

TABLE II. EFFECT OF GAMMA IRRADIATION ON THE EMERGENCE AND LONGEVITY OF MEDFLY PUPAE IRRADIATED AT 9, 10, 11 and 14 krad ONE DAY BEFORE ADULT ECLOSION

Treatment	Per cent emergence	Per cent mortality			
		Male	Female	Total ^a	Total ^b
9 krad	83	34	25	59	92
10 krad	75	41	29	70	95
11 krad	69	54	38	92	100
14 krad (partial nitrogen)	78	32	27	59	91
<i>Control</i>	91	25	20	45	87

^a Three weeks of data, with three replications.

^b Six weeks of data on males and females.

TABLE III. STERILITY AND SEXUAL COMPETITIVENESS OF MEDFLY MALE PUPAE TREATED AT 9, 10 AND 14 krad TWO DAYS BEFORE ADULT ECLOSION

Treatment	Sterility test		Sexual competitiveness		Competitiveness value
	No. of eggs examined	Mean % egg hatch \pm SE	No. of eggs examined	Mean % egg hatch \pm SE	
9 krad	4799	18.51 \pm 3.67	3588	65.58 \pm 4.10	0.18
10 krad	4881	16.12 \pm 3.10	3059	70.57 \pm 4.00	0.13
14 krad (partial nitrogen)	4788	0	3092	61.77 \pm 2.83	0.16
<i>Control</i>	5374	85.78 \pm 1.20	3390	91.25 \pm 3.35	—

TABLE IV. STERILITY AND SEXUAL COMPETITIVENESS OF MEDFLY MALE PUPAE TREATED AT 9, 10, 11 AND 14 krad ONE DAY BEFORE ADULT ECLOSION

Treatment	Sterility test		Sexual competitiveness		Competitiveness value
	No. of eggs examined	Mean % egg hatch \pm SE	No. of eggs examined	Mean % egg hatch \pm SE	
9 krad	2667	2.53 \pm 1.10	2926	61.70 \pm 3.05	0.16
10 krad	2895	0.45 \pm 0.50	2483	66.02 \pm 2.92	0.12
11 krad	2422	0.10 \pm 0.20	2793	71.60 \pm 4.16	0.08
14 krad (partial nitrogen)	2547	1.99 \pm 1.60	2515	51.92 \pm 2.06	0.25
<i>Control</i>	2891	90.47 \pm 4.67	3205	89.34 \pm 3.43	—

as compared with the 9, 10 and 11 krad doses, probably because of the less detrimental effects of ionizing radiation on the somatic cells in a nitrogen medium. The mortality was 59% for adults resulting from pupae which were irradiated in nitrogen one day before adult eclosion, whereas it was 44% for adults whose pupae were irradiated two days before adult eclosion. This finding confirms the results of some earlier studies, which indicated the adverse effect of the irradiation of older pupae in nitrogen on the survival of medfly adults [4].

However, it is known that increasing doses of irradiation beyond a certain level progressively affect the survival of males, not only at the higher doses applied in nitrogen, but also in ambient atmospheres [13, 14]. In all treatments the percentage of mortality of the males was higher than that of females. Indeed, some researchers have indicated that gamma irradiated females live considerably longer than irradiated males and even longer than wild females [15]. Data on sterility and sexual competitiveness are given in Tables III and IV, respectively.

Males irradiated two days before adult eclosion in air at 9 and 10 krad were 81.49% and 83.88% sterile, respectively, whereas males irradiated in partial nitrogen were 100% sterile. Values for the sexual competitiveness of males assessed on the basis of the suppression of egg hatching of normal flies were found to be 0.18 and 0.13 for males from pupae treated at 9 and 10 krad. The CV of males from pupae treated in partial nitrogen at 14 krad was found to be 0.16.

Males irradiated one day before adult eclosion in air at 9, 10 and 11 krad were 97.47, 99.55 and 99.90% sterile, respectively. Males irradiated in partial nitrogen at 14 krad were 98.01% sterile. Although there was no significant difference between the percentages of sterility, the competitiveness values of males irradiated in partial nitrogen were always larger than for males irradiated in air. Male pupae irradiated one day before adult eclosion in partial nitrogen had higher competitiveness values than male pupae in the same medium two days before adult eclosion. However, these values, which were found to be 0.16 and 0.25, were considerably lower as compared with the results of several previous investigations. This is most likely due to the lack of continuous nitrogen flushing during the irradiation period of our experiment. This once again confirms that the competitiveness of medfly males is inversely proportional to the doses of irradiation and directly proportional to the age of the pupae when irradiated.

REFERENCES

- [1] AKMAN, K., ZÜMREOĞLU, A., Effects of gamma radiation on the immature pupae of the Mediterranean fruit fly (*Ceratitis capitata* Wied.): Dose response of laboratory reared and wild strains, *Türk Bitki Kor. Derg.* 2 1 (1979) 37-42.
- [2] HOOPER, G.H.S., "Sterilization of the Mediterranean fruit fly: A review of laboratory data", Sterile-Male Technique for Control of Fruit Flies (Proc. Panel Vienna, 1969), IAEA, Vienna (1970) 3-11.
- [3] KATIYAR, K.P., RAMÍREZ, E., "Some effects of gamma radiation on the sexual vigour of *Ceratitis capitata* (Wiedemann)", Sterile-Male Technique for Control of Fruit Flies (Proc. Panel Vienna, 1969), IAEA, Vienna (1970).
- [4] LANGLEY, P.A., MALY, H., Control of Mediterranean fruit fly (*Ceratitis capitata* Wied.) using sterile-males: Effects of nitrogen and chilling during gamma irradiation of puparia, *Entomol. Exp. Appl.* 14 (1971) 137-146.
- [5] OHINATA, K., CHAMBERS, D.L., FUJIMOTO, M., KASHIAWI, S., MIYABARA, R., Sterilization of the Mediterranean fruit fly by irradiation: Comparative effectiveness of treated pupae and adults, *J. Econ. Entomol.* 64 4 (1971) 701.

- [6] WAKID, A.M., Effect of nitrogen during gamma irradiation of puparia and adults of the Mediterranean fruit fly on emergence, sterility, longevity and competitiveness, *Environ. Entomol.* **2** (1973) 37-40.
- [7] ZÜMREOĞLU, A., OHINATA, K., FUJIMOTO, M., HIGA, H., HARRIS, E.J., Gamma irradiation of the Mediterranean fruit fly. Effect of treatment of immature pupae in nitrogen on emergence, longevity, sterility, sexual competitiveness, mating ability and pheromone production of males, *J. Econ. Entomol.* **72** 2 (1979) 173-176.
- [8] HOOPER, G.H.S., KATYAR, K.P., Competitiveness of gamma-sterilized males of the Mediterranean fruit fly, *J. Econ. Entomol.* **64** (1971) 1068-1071.
- [9] BARRON, E.S.G., "The effect of X-rays on systems of biological importance", *Radiation Biology* (HOLLANDER, A., Ed.), McGraw-Hill, New York (1954) 283-314.
- [10] OHINATA, K., ASHRAF, M., HARRIS, E.J., Mediterranean fruit flies. Sterility and sexual competitiveness in the laboratory after treatment with gamma irradiation in air, carbon dioxide, helium, nitrogen or partial vacuum, *J. Econ. Entomol.* **70** (1977) 165-168.
- [11] ZÜMREOĞLU, A., TANAKA, N., HARRIS, E.J., The need for wheat germ in larval diets of the Mediterranean fruit fly (*Ceratitis capitata* Wied.) and of non-nutritive bulking material, *Türk. Bitki Kor. Derg.* **3** 3 (1979) 131-138.
- [12] FRIED, M., Determination of sterile insect competitiveness, *J. Econ. Entomol.* **64** (1971) 869-872.
- [13] FERON, M., Sterilisation de la mouche méditerranéenne des fruits *Ceratitis capitata* Wied. par irradiation des pupes aux rayons gamma, *Ann. Epiphyt.* **17** (1966) 220-239.
- [14] KEISER, I., SCHNEIDER, E.L., Longevity, resistance to deprivation of food and water and susceptibility to Malathion and DDT of Oriental fruit flies, Melon flies and Mediterranean fruit flies with Tepa or radiation, *J. Econ. Entomol.* **58** (1969) 682-685.
- [15] STEINER, L.F., "Methods of estimating the size of populations of the sterile pest Tephritidae in release programs", *Insect Ecology and The Sterile-Male Technique* (Proc. Panel Vienna, 1967), IAEA, Vienna (1969) 63-72.

IRRADIATION/STERILIZATION TECHNIQUES FOR *Anastrepha suspensa* Loew AND THEIR IMPACT ON BEHAVIOURAL QUALITY

C.O. CALKINS, K.A.A. DRAZ
Insect Attractants, Behavior and
Basic Biology Research Laboratory,

B.J. SMITTLE
Insects Affecting Man and Animals
Research Laboratory,

Agricultural Research Service,
United States Department of Agriculture,
Gainesville, Florida,
United States of America

Abstract

IRRADIATION/STERILIZATION TECHNIQUES FOR *Anastrepha suspensa* Loew AND THEIR IMPACT ON BEHAVIOURAL QUALITY.

Mature pupae of *Anastrepha suspensa* Loew were exposed to gamma radiation to establish the sterilizing effect of 1–11 krad doses. Probit analyses indicated that 1.314 krad (1.203–1.455 krad) and 1.622 krad (1.469–1.797 krad) would result in 95 and 99% male sterility, respectively. Female sterility was 100% and no eggs were produced when pupae were exposed at 1 krad. Increasing the radiation dose above 1 krad reduced the percentage of eclosion and the number of viable males. The ability to fly vertically was affected only after exposure at 11 krad. Increasing the radiation dose also affected mating success. When sterile and fertile males were held in equal numbers with fertile females, an increase in egg hatch was correlated with increased radiation dose. When sterile males were held with fertile males and females, the sterile flies appeared to be competitive at all ratios and the reduction in egg hatch correlated positively with the increase in the 'overflowing' ratio.

1. INTRODUCTION

Fruit flies of the Tephritidae family attack many different varieties and species of tropical and subtropical fruits. In recent years, entomologists have been using the sterile insect technique to attempt to eradicate certain species of fruit flies from localized areas to protect such fruits [1–4].

Sterilization is achieved by gamma radiation administered during the pupal stage. In the case of the Mediterranean fruit fly (medfly), *Ceratitits capitata* Wiedemann, 9 krad of radiation in air caused 98–99% sterility [5–7].¹ The recommended dose for a large eradication programme in Mexico was 17 krad in

¹ 1 rad = 1.00×10^{-2} Gy.

nitrogen or in hypoxia [4], which resulted in 99.8% sterility in the male. In the melon fly, *Dacus cucurbitae* Coq., a dose of 7 krad gamma irradiation was recommended and resulted in the successful eradication of that species from the Okinawa Prefecture [3].

In Florida, the only established tephritid pest is the Caribbean fruit fly (caribfly), *Anastrepha suspensa* Loew. With the demise of ethylene dibromide fumigant, this species has become a major threat to the shipment of citrus products (primarily grapefruit) to Japan. The citrus industry and several government agencies have proposed the establishment of citrus growing areas that could be kept free of this fruit fly. The establishment of these fly-free areas would allow shipment of citrus to California and to Japan without treatment for infestation. Several methods have been proposed to eliminate fly populations and to prevent re-entry into these established areas, including the release of sterile flies.

Recently, the construction of a Caribbean fruit fly rearing 'factory' in Gainesville, Florida, has made the possibility of large releases of sterile flies a reality. The production capacity of the factory is c. 50 million flies per week. The irradiator will contain ^{137}Cs .

The dosage rate for sterilizing the caribfly has not been established as yet. The purpose of this study was to determine the levels of sterility of male and female caribflies induced by different doses of irradiation, and the impact of those doses on the quality or effectiveness of the flies.

2. MATERIALS AND METHODS

The insects were taken from a colony of Caribbean fruit flies that has been reared at the USDA-ARS Insect Attractants, Behavior and Basic Biology Research Laboratory in Gainesville, Florida since 1973. Larvae used in this study were reared on a corn-cob grits based diet. The pupae were maintained at 25°C for 12 days in fine vermiculite. On the thirteenth day, they were separated from the media by sifting and were exposed to ^{137}Cs in a Gammator M[®] gamma cell that emitted 1630 rad/min, located at the USDA-ARS Insects Affecting Man and Animals Research Laboratory. Pupae undergoing irradiation were held in lots of 2000 in 20 mL ventilated plastic vials for exposures of 1, 3, 5, 7, 9 and 11 krad in air.

Each sample was confined in a separate cage for emergence and provided with adult food and water. Adult females that emerged within 24 h were separated and placed in separate cages. Adult males, which eclosed one day later than females, were placed in a separate cage 24 to 48 h after eclosion began. Flies that were not irradiated, but were subjected as pupae to all of the same handling procedures, served as controls and as fertile mates.

Mating and oviposition cages were set up with adult food and water. The screened cage consisted of a plastic cup (473 mL) with a 3 cm × 6 cm hole in the bottom, which was covered by a wax membrane to serve as an oviposition surface.

Another plastic cup (236 mL), which contained c. 50 mL of water, was fixed to the bottom to ensure 100% humidity inside, thus preventing desiccation of the eggs.

To measure the sterility of males, three 10 day old fertile females and three 10 day old males from a specified irradiation treatment were placed in each cage. To measure the sterility of females, reciprocal crosses were conducted with three fertile males and three females from a specified treatment. The controls consisted of cages with three fertile males and three fertile females. Each treatment and control was replicated four times. All cages were held under a 14:10 light:dark cycle at 25°C and 70% relative humidity.

Eggs deposited through the wax membrane either adhered to the inside surface or fell into the water. Eggs were collected daily for six days and were transferred to moist, black filter paper in 90 mm Petri dishes. The eggs were held at 27°C for four days. At the end of this time, the eggs were examined under magnification to determine hatch.

Data were collected on the following parameters of quality in relation to irradiation dose: adult eclosion rate, sex ratio, flight ability and mating competitiveness. The per cent eclosion and sex ratio were determined by placing 100 puparia in covered Petri dishes. The flight ability test was conducted in plastic tubes, 14 cm high × 9 cm OD to determine if the flies could fly in a vertical direction [8]. The test was replicated four times. The outside surface of each tube was painted black to exclude light. The inside surface was coated with unscented talcum powder to prevent flies from walking up the sides. Twenty 1 day old males or females were chilled at 6°C for 2 min to immobilize them and were then placed in the bottom of the tube. As the flies recovered, they began to fly out. After 30 min, the tubes were covered and the number of flies remaining in each tube was determined.

Of our two mating competitiveness tests, one consisted of placing ten fertile females, ten fertile males and ten males irradiated at 3, 5, 7, or 9 krad in an oviposition cage described previously. Each treatment was replicated four times. Eggs were collected each day during a six day period. A sample of 100 eggs per replication was placed on black filter paper and held for egg hatch. The test was repeated to assure reproducibility.

The other competitiveness test consisted of placing fertile and sterile males with fertile females in the following ratios: 10:10:10, 10:30:10, 10:60:10 and 10:90:10 in the same oviposition cages. Each treatment was replicated four times. All irradiated males received a dose of 3 krad, which was sufficient for more than 99% sterility, as determined by the previous experiment. Eggs were collected and held as described above. The test was repeated twice. The results of these tests were analysed by analysis of variance and the means were separated by Duncan's Multiple Range Test.

TABLE I. THE EFFECT OF IRRADIATION ON THE STERILITY OF CARIBBEAN FRUIT FLY MALES MATED WITH FERTILE FEMALES

Number of eggs	Irradiation dose (krad)						
	0	1	3	5	7	9	11
Day 1							
No. of eggs	250	260	245	270	170	215	195
Per cent hatch	96	24	0	0	0	0	0
Day 2							
No. of eggs	225	325	405	150	255	405	260
Per cent hatch	93	24	0	0	0	0	0
Day 3							
No. of eggs	295	230	250	250	180	255	185
Per cent hatch	97	21	0	0	0	0	0
Day 4							
No. of eggs	200	230	240	250	210	270	265
Per cent hatch	98	21	0	0	0	0	0
Day 5							
No. of eggs	265	225	215	155	110	230	220
Per cent hatch	92	12	0	0	0	0	0
Day 6							
No. of eggs	270	300	265	265	145	240	225
Per cent hatch	81	6	0	0	0	0	0

TABLE II. THE EFFECT OF INCREASING DOSES OF IRRADIATION ON ADULT ECLOSION, SEX RATIO AND FLIGHT ABILITY

Irradiation dose (krad)	Eclosion (%)	Sex ratio (Male:female)	Per cent fliers*	
			Male	Female
0 (control)	84	48:52	76 ^b	89 ^b
1	83	42:58	76 ^b	89 ^b
3	84	40:60	76 ^b	84 ^b
5	81	36:64	71 ^b	76 ^{ab}
7	74	34:66	71 ^b	81 ^b
9	72	34:66	67 ^b	83 ^b
11	67	29:71	48 ^a	66 ^a

* Numbers in the same column followed by the same superscript letter are not significantly different at the 0.01 level according to Duncan's Multiple Range Test.

3. RESULTS AND DISCUSSION

Irradiation of Caribbean fruit fly pupae at one and two days prior to eclosion results in sterility at lower doses than expected. Females exposed to 1 krad or higher produced no eggs. Males irradiated at 1 krad were about 82% sterile (Table I). A probit analysis indicated that these males would be 95% sterile at 1.314 krad (1.203–1.455 krad) and 99% sterile at 1.611 krad (1.469–1.797 krad) ($P < 0.05$). No eggs from fertile females were observed to hatch when they were mated with males exposed to 3 krad of radiation.

Burditt et al. [9] found that irradiation of caribflies in air at 3, 4, 5 and 6 krad resulted in 5.3, 2.1, 0.8 and 0.1% egg hatch. Sharp et al. [10] reported that for irradiation at 2, 3, 4 and 5 krad in nitrogen, egg hatch percentage rates were 6.4, 4.5, 0.2 and 0.1, respectively. No probit analyses of these data were conducted in either case. These sterilizing doses are much lower than those required for *C. capitata* [7]. One explanation might be that the adult prereproductive periods in the two species are quite different. Medflies, in the laboratory, are fully mature in four days. Males have been known to mate at one day after eclosion [11]. In contrast, *A. suspensa* is not fully mature until nine days. The earliest mating attempts and 'calling' have been noted at six days. Presumably, the longer development of the reproductive system of *A. suspensa* indicates that at the time of irradiation it is only in the initial stages, and probably is more susceptible to irradiation damage.

Increasing the irradiation dosage affected the percentage of eclosion, the sex ratio and the ability to fly (Table II). The adult eclosion is only materially affected at 7 krad and above, but the sex ratio was affected progressively with each increment of irradiation. Apparently, males are more deleteriously affected than females. This may be due to the fact that male adults, which eclose approximately one day later than females, may be in an earlier stage of development than females and therefore may be more susceptible to irradiation damage. Only the highest dose rate (11 krad) affected the flight ability of males (Table II).

In mating competitiveness tests, increasing irradiation doses were found to be deleterious to mating success. When sterile and fertile males were held in equal numbers with fertile females, but the sterile males were irradiated at increasing increments of irradiation, the egg hatch percentage increased (Table III). This indicates that either the sterile males were not as likely to copulate, their sperm was not as competitive in searching, or both.

However, males sterilized with a 3 krad dose were competitive with fertile males at all of the 'overflowing' ratios tested (Table IV). Admittedly, the mating/oviposition cages were small and the flies were forced into close proximity. If given more space, the results may have been more dramatic. This was found to be the case with *C. capitata* for mating propensity [12]. Our subsequent studies will deal with spacing.

The effects of a low irradiation dose (3 krad) are not as deleterious as those that are higher, yet 100% sterility is still possible. The irradiation dose for *A. suspensa*

TABLE III. THE EFFECT OF IRRADIATION DOSES ON EGG HATCH WHEN STERILE AND FERTILE CARIBBEAN FRUIT FLY MALES ARE HELD IN EQUAL NUMBERS WITH FERTILE FEMALES

Irradiation dose (krad)	Mean percentage of egg hatch*	
	Test 1	Test 2
0 (<i>control</i>)	90 ^d	88 ^e
3	39 ^a	39 ^a
5	49 ^b	47 ^b
7	67 ^c	62 ^c
9	73 ^c	74 ^d

* Numbers in the same column followed by the same superscript letter are not significantly different at the 0.01 level according to Duncan's Multiple Range Test.

TABLE IV. THE EFFECT OF OVERFLOODING RATIOS OF STERILE TO FERTILE MALES ON EGG HATCH OF FERTILE FEMALES

Overflooding ratio (female:sterile male:fertile male) (krad)	Mean percentage of egg hatch*	
	Test 1	Test 2
1:0:1 (<i>control</i>)	93 ^c	91 ^e
1:1:1	56 ^b	36 ^d
1:3:1	23 ^a	29 ^c
1:6:1	21 ^a	19 ^b
1:9:1	7 ^a	10 ^a

* Numbers in the same column followed by the same superscript letter are not significantly different at the 0.01 level according to Duncan's Multiple Range Test.

destined for release in Florida will be chosen by the officials of the Florida Department of Plant Industry. However, from this study, it appears that a dose of 3 krad will result in the release of fully sterile flies with minimal effect on quality or effectiveness.

ACKNOWLEDGEMENTS

The authors thank V. Chew for analysing the sterility data by probit analysis, E. Turner for typing the manuscript and R. Rutter for supplying the insects.

REFERENCES

- [1] CHAMBERS, D.L., SPENCER, N.R., TANAKA, N., CUNNINGHAM, R.T., "Sterile-insect technique for eradication or control of the melon fly and Oriental fruit fly: Review of current status", *Sterile-Male Technique for Control of Fruit Flies (Proc. Panel Vienna, 1969)*, IAEA, Vienna (1970) 99-102.
- [2] HARRIS, E.J., "Releasing sexually-sterilized Mediterranean fruit flies for controlling the insect in North Africa: Possibilities of use and problems involved", *ibid.*, pp. 77-80.
- [3] IWAHASHI, O., Eradication of the melon fly, *Dacus cucurbitae*, from Kume Is., Okinawa, with the sterile insect release method, *Res. Popul. Ecol.* 19 (1977) 87-98.
- [4] SCHWARZ, A.J., ZAMBODA, A., OROZCO, D.H.S., ZAVALA, J.L., CALKINS, C.O., Mass production of the Mediterranean fruit fly at Metapa, Mexico, *Fla. Entomol.* 68 (1985) 467-477.
- [5] KATTIYAR, K.P., VALERIO, J., "Further studies on the possible use of sterile-male release technique in controlling or eradicating the Mediterranean fruit fly, *Ceratitis capitata* Wied., from Central America", *Peaceful Applications of Nuclear Energy (Proc. 5th Inter-American Symp. Valparaiso, Chile, 1964)*, Pan-American Union, Washington, DC (1964) 197-202.
- [6] KATTIYAR, K.P., RAMIREZ, E., "Some effects of gamma radiation on the sexual vigour of *Ceratitis capitata* (Wiedemann)", *Sterile-Male Technique for Control of Fruit Flies (Proc. Panel Vienna, 1969)*, IAEA, Vienna (1970) 83-84.
- [7] HOOPER, G.H.S., Competitiveness of gamma-sterilized males of the Mediterranean fruit fly: Effects of irradiating pupal or adult stage and of irradiating pupae in nitrogen, *J. Econ. Entomol.* 64 (1971) 1364-1368.
- [8] DRAZ, K.A.A., CALKINS, C.O., unpublished data.
- [9] BURDITT, A.K., Jr., et al., "Application of sterilization techniques to *Anastrepha suspensa* Loew in Florida, United States of America", *Sterility Principle for Insect Control 1974 (Proc. Int. Symp. Innsbruck, 1974)*, IAEA, Vienna (1975) 93-100.
- [10] SHARP, J.L., ASHLEY, T.R., BENNETT, D.R., SMITTLE, B.J., Emergence, longevity, fecundity and sterility of *Anastrepha suspensa* (Diptera:Tephritidae) irradiated in nitrogen, *J. Ga. Entomol. Soc.* 10 (1975) 241-250.
- [11] CALKINS, C.O., personal communication.
- [12] CHAMBERS, D.L., CALKINS, C.O., BOLLER, E.F., ITO, Y., CUNNINGHAM, R.T., Measuring, monitoring and improving the quality of mass-reared Mediterranean fruit flies, *Ceratitis capitata* (Wied.), *Z. Angew. Entomol.* 95 (1983) 285-303.

**EFFECTOS GENETICOS Y AMBIENTALES
SOBRE EL PESO DE *Lixophaga diatraeae*
(DIPTERA:TACHINIDAE)
A DIFERENTES EDADES**

J.L. GOICOECHEA, J. ALEMAN,
Y. FRAGA, A. PEREZ
Centro Nacional de Sanidad Agropecuaria,
La Habana, Cuba

Abstract-Resumen

GENETIC AND ENVIRONMENTAL EFFECTS ON THE WEIGHT OF *Lixophaga diatraeae* (DIPTERA:TACHINIDAE) AT DIFFERENT STAGES OF DEVELOPMENT.

The relationships between the initial weight of pupa, weight after 24 hours and initial imago weight were studied, together with the effects on the latter of the larval and pupal cycles, the effective weight of the substitute host (*Galleria mellonella*) and sex. The three characters showed low hereditability and susceptibility during the cycle. The most important effects detected were those of host weight and of sex.

EFFECTOS GENETICOS Y AMBIENTALES SOBRE EL PESO DE *Lixophaga diatraeae* (DIPTERA:TACHINIDAE) A DIFERENTES EDADES.

Se estudiaron las relaciones entre los pesos inicial de la pupa, a las 24 horas, e inicial de los imagos y los efectos que sobre estos ejercen los ciclos larval y pupal, el peso efectivo del hospedante de sustitución (*Galleria mellonella*) y el sexo. Los tres caracteres mostraron bajas heredabilidades y susceptibilidad por la duración del ciclo. Los efectos más importantes detectados fueron los del peso del hospedante y los del sexo.

1. INTRODUCCION

Lixophaga diatraeae (Townsend) es una mosca taquinida empleada en la lucha contra el perforador de los tallos de la caña de azúcar *Diatraea saccharalis* (Fabricius).

Chambers [1] en una revisión bibliográfica analizó el valor de los estudios ecológicos, fisiológicos y genéticos para la adecuada explotación de insectos en programas de control biológico o de manejo genético de plagas. Por otra parte, Mackauer [2] discutió la validez de la selección para el mejoramiento de diversos caracteres, incluyendo la fertilidad, en enemigos naturales. Estos aspectos, excluyendo los ecológicos, han sido poco tratados en *L. diatraeae*.

Etienne [3] demostró que cuanto mayor era la talla de las hembras de esta especie tanto más aumentaba la cantidad de huevos en los oviductos. McPherson en 1975 —citado por Grenier [4]— corroboró este resultado, mientras que King et

al. [5]. encontraron una relación lineal y proporcional entre el peso de las hembras y la producción de huevos, quedando explicada la variabilidad de la fertilidad en un 80% por el peso.

Sobre la base de estos antecedentes, se estudiaron las relaciones entre diversos pesos en las fases pupal e imaginal y otros caracteres con vistas a sustentar un esquema de selección precoz para incrementar la fertilidad, a partir del estadio pupal.

2. MATERIALES Y METODOS

2.1. Condiciones de cría

Los ejemplares con los que se desarrollaron los experimentos provinieron de una población del laboratorio de genética de insectos del Centro Nacional de Sanidad Agropecuaria.

Todas las manipulaciones se llevaron a cabo según lo establecido en la Norma Ramal 180 [6], empleándose larvas de *Galleria mellonella* (Linneo) como hospedante de sustitución, las cuales se parasitaron a razón de dos larvas de *L. diatraeae* por cada una de éstas.

Los experimentos se realizaron a una temperatura variable cuya media fue de $26,2 \pm 2,4^{\circ}\text{C}$, humedad relativa superior al 80% y fotoperíodo natural.

2.2. Variables y efectos considerados

A cada uno de los individuos se les midió o controló los caracteres relacionados en el Cuadro I.

Los pesos se tomaron en una balanza analítica con error de 0,1 mg, las longitudes se midieron con un pie de rey con error de 0,02 mm y las observaciones relativas al ciclo de vida se hicieron en intervalos de 12 horas, expresándolas en días.

2.3. Efectos sobre los pesos iniciales de la pupa y el imago

Las relaciones entre las variables y efectos fueron estudiadas mediante modelos lineales, realizando más de uno para los pesos de interés.

Se consideraron el efecto del sexo, la duración del ciclo larval, el peso efectivo de *Galleria* y la longitud pupal sobre el peso inicial de la pupa.

Para el peso inicial del imago se analizaron los efectos del sexo, el ciclo larval, el ciclo pupal, el peso efectivo de *Galleria* y el peso inicial de la pupa.

Se calcularon las correlaciones entre los pesos inicial de la pupa, a las 24 horas, inicial del imago y la longitud pupal.

CUADRO I. VARIABLES Y EFECTOS CONTEMPLADOS EN LOS EXPERIMENTOS

Variable	Símbolo	Descripción
Peso inicial de la pupa	PIP	Peso (mg) de las pupas las primeras 12 horas
Peso pupal a las 24 horas	P24	Peso (mg) a las 24 horas del anterior
Peso inicial del imago	PAD	Peso (mg) imaginal en las primeras 12 horas
Longitud pupal	LOP	Longitud (mm) del eje mayor del pupario
Peso efectivo de <i>Galleria</i>	PEG	Peso de <i>Galleria</i> por larva III de <i>Lixophaga</i>
Ciclo larval	CIL	Duración (días) desde la inoculación hasta la pupación
Ciclo pupal	CIP	Duración (días) desde la pupación hasta la emersión
Sexo	SEX	

2.4. Estimación de las heredabilidades

Las heredabilidades de los pesos considerados fueron calculadas mediante el diseño biparental —BIP— [7], considerando familias de hermanos completos. Para ello se aparearon masivamente machos y hembras, extrayendo las parejas en cópula para controlar así a los progenitores.

3. RESULTADOS Y DISCUSION

Las relaciones encontradas entre las variables y efectos incluidos en el estudio se obtuvieron de la integración de los modelos analizados, reflejándose las tendencias generales (Fig. 1).

Las machos y hembras de *L. diatraeae* manifestaron diferencias para cada una de las variables consideradas, resultando los primeros menos pesados, largos y con ciclos más cortos que las hembras (Cuadro II). King y Martin [8] y Grenier [4] informaron un comportamiento similar para los pesos pupales y el ciclo de desarrollo en esta especie.

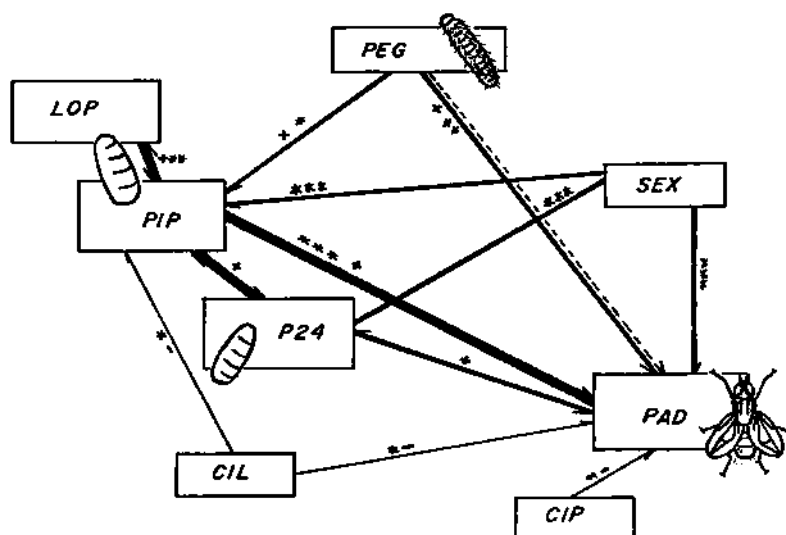

FIG. 1. Relaciones observadas entre los variables estudiadas. (La explicación de los símbolos se encuentra en el Cuadro I.)

CUADRO II. DIFERENCIAS SEXUALES EN CARACTERES LARVALES, PUPALES Y DEL IMAGO DE *Lixophaga diatraeae*

Carácter ^a	Machos		Hembras	
	$\bar{X} \pm s\bar{x}$	n	$\bar{X} \pm s\bar{x}$	n
CIL	9,69 \pm 0,03	290	10,02 \pm 0,03	304
CIP	12,54 \pm 0,03	290	13,27 \pm 0,03	304
PIP	18,7 \pm 0,2	274	23,5 \pm 0,2	293
P24 ^b	15,8 \pm 0,2	150	19,8 \pm 0,2	150
PAD	11,3 \pm 0,1	143	13,5 \pm 0,1	187
LOP	3,79 \pm 0,02	143	4,08 \pm 0,03	188

^a Todas las medias difirieron en $p < 0,01$.

^b Tomado de Goicoechea et al. (1987) [9].

CUADRO III. PARAMETROS ESTIMADOS PARA LAS COVARIABLES DE LOS MODELOS^a

Covariables	Sobre el PIP		Sobre el PAD	
CIL	- 1,53	- 0,59	- 0,86	- 0,20
CIP	—		- 0,79	- 0,39
PEG	0,02	0,03	≪ 1	0,01
LOP	3,08		—	
PIP	—		0,41	0,48

^a Se listan los valores mínimos y máximos.

Katz y Young [10] detectaron diferencias entre los pesos por sexos en *Drosophila melanogaster*, atribuyéndolo a efectos de escala por la relaciones observadas entre medias y varianzas. Este comportamiento se observó en *L. diatraeae* (datos no publicados), no poniéndose de manifiesto en los resultados aquí mostrados por presentarse depurados de los efectos incluidos en los análisis. Estos autores, a partir del comportamiento de las heredabilidades realizadas entre los sexos, plantearon la existencia de ligamiento al sexo para el peso del adulto, hipótesis que no debe descartarse para *L. diatraeae*.

Los efectos de la densidad de larvas de *L. diatraeae* por hospedero han sido analizados por varios autores [4, 5, 11-13], los que concluyeron en una relación negativa entre ésta y el peso del estadio considerado. King et al. [5] informan que el peso de los puparios de la mosca aumenta cuanto mayor es el estadio de la larva hospedera a una densidad de inoculación fija. Atendiendo a estas razones se incluyó en los modelos la covariable peso efectivo de *Galleria* (PEG), que unifica al peso del hospedante y la densidad en una relación que explica sus efectos.

Se observó que el PEG afectó significativamente a los pesos evaluados, lo cual se explica por la disponibilidad de alimento (Fig. 1, Cuadro III). No se encontró significación en el PEG cuando se incluyó junto al peso inicial de la pupa (PIP) como covariables sobre el peso del adulto (PAD), mostrando que en la medida que las relaciones son más indirectas pierden su fortaleza estadística. La acción del PEG es directa sobre el PIP.

La relación del ciclo larval (CIL) sobre el PIP fue negativa (Fig. 1, Cuadro III), lo cual puede explicarse por una velocidad de desarrollo larval variable condicionada metabólicamente. Grenier [14] demostró que como promedio se producen la primera y segunda muda larvales al arribar éstas a $0,23 \times 3,2$ mg, respectivamente. Por tanto, aquellas que alcancen esos pesos más rápidamente, por una mayor eficiencia en la conversión del alimento, harán como promedio ciclos más cortos. Esta relación se transmite indirectamente sobre el peso del adulto.

CUADRO IV. COEFICIENTES DE CORRELACION ENTRE PESO Y LONGITUD PUPAL EN *L. diatraeae*

	P24	PAD	LOP
PIP	0,99 ^a	0,92 ^b 0,84 ^b	
P24		0,92 ^b	
PAD			0,65 ^b

^a $p < 0,001$.

^b $p < 0,01$.

De forma análoga el ciclo pupal (CIP) afectó negativamente al PAD (Fig. 1, Cuadro III). Durante la fase pupal se consumen las reservas acumuladas, de modo que mientras más largo es este período mayor debe ser la pérdida de peso y por ende menos pesados deben ser los imagos. Yamada [15] observó un efecto similar in *Tribolium*.

La temperatura en que se condujeron los experimentos está dentro del intervalo óptimo para esta especie [16, 8], de manera que las diferencias observadas en la duración del CIL y del CIP, independientemente del sexo, pueden indicar algún grado de determinación genética sobre éstos. Englert y Bell [17] seleccionaron líneas con ciclos larvales más o menos largos, encontrando respuestas correlacionadas sobre el peso de las larvas a los 13 días y de las pupas en *T. castaneum*. Los efectos del CIL y del CIP pueden tener teóricamente el mismo comportamiento demostrado por estos autores y deben tomarse en consideración en futuros trabajos.

La longitud pupal (LOP) mostró una elevada correlación con los pesos considerados (Cuadro IV), y explicó significativamente parte de la variación del PIP (Fig. 1, Cuadro III).

Esta asociación puede ser explotada, como lo hacen Boller et al. [18] en la mosca del Mediterráneo, dentro de los elementos de control de la calidad de la cría y como criterio de selección.

Los elevados valores obtenidos en las correlaciones entre los pesos (Cuadro IV), especialmente entre los pupales, brindan un margen de seguridad al trabajo de selección, esto es, hasta 24,5 horas posteriores al inicio de la pupación pueden pesarse sin que se manifieste una pérdida importante en el efecto final sobre el peso del adulto. Esta consideración cobrará fuerza con el cálculo de las correlaciones genéticas entre estos caracteres. Por otra parte, el empleo del peso a las 24 horas de la pupación tiene la ventaja sobre el peso inicial de que en ese momento deben haber concluido los cambios de instar.

Las estimaciones de heredabilidad de los tres pesos considerados fueron bajas (Cuadro V), indicando una débil influencia genética y marcada susceptibilidad

CUADRO V. COMPONENTES DE VARIANZAS Y HEREDABILIDADES ESTIMADAS PARA PIP, P24 Y PAD

Fuente de variación	gl	CM ^a	E(CM) ^b
Peso inicial de la pupa			
CIL	1	105,362	
PEG	1	180,511	
Familias	34	5,5894	0,3724
Error	106	4,1176	4,1176
	Heredabilidad	0,17 + 0,06	
Peso pupal a las 24 horas			
Familias	30	37,0376	1,3324
Error	493	14,6293	14,6293
	Heredabilidad	0,16 + 0,07	
Peso inicial del adulto			
CIL	1	25,5092	
CIP	1	10,1314	
PEG	1	35,8185	
Familias	34	2,2285	0,1784
Error	105	1,5406	1,5406
	Heredabilidad	0,21 + 0,09	

^a Cuadrados medios.

^b Valores esperados de los cuadrados medios.

ambiental, demostrada aquí por la calidad nutricional (PEG) y la duración del ciclo de vida (CIL y CIP).

Se aplicó para el análisis de estos parámetros genéticos el modelo biparental atendiendo a restricciones, al parecer conductuales, de las moscas en la cópula en cautiverio. Cuando se confinó un macho con tres o cuatro hembras, como exige la estimación de heredabilidad a partir de familias de medios hermanos paternos, ninguna hembra resultó fecundada; sin embargo, cuando se ubicaron 10 machos y 10 hembras, en poco tiempo pudieron ser colectadas parejas en cópula que se extrajeron para la conducción de los experimentos.

Los resultados hasta aquí obtenidos no invalidan la hipótesis de la selección precoz. En principio, la búsqueda de una respuesta correlacionada sobre el peso del

adulto a partir del PIP o del peso pupal a las 24 h (P24) es posible por la alta correlación que muestran y la fuerte influencia que ejerce el PIP sobre el primero. Queda entonces por optimizar las condiciones ambientales para mejorar la respuesta esperada, lo cual es posible mediante el control del manejo de las crías.

4. CONCLUSIONES

- 1) El peso efectivo de *Galleria* (PEG), el ciclo larval (CIL) y el sexo constituyen elementos moduladores del peso inicial de las pupas (PIP) de *L. diatraeae*.
- 2) Sobre el peso del adulto (PAD) ejercen influencias marcadas el peso inicial de las pupas (PIP), el peso efectivo de *Galleria* (PEG), la duración del ciclo larval (CIL) y pupal (CIP) y el sexo (SEX).
- 3) Los pesos estudiados y la longitud pupal (LOP) muestran correlaciones elevadas y significativas, lo cual sustenta la hipótesis trazada.
- 4) Los efectos ambientales considerados influyen marcadamente sobre los pesos analizados, lo cual corrobora los bajos valores de heredabilidad obtenidos.

REFERENCIAS

- [1] CHAMBERS, D.L., Quality control in mass rearing, *Annu. Rev. Entomol.* **22** (1977) 289-308.
- [2] MACKAUER, M., Genetic problems in the production of biological control agents, *Annu. Rev. Entomol.* **21** (1976) 369-385.
- [3] ETIENNE, J., *Lixophaga diatraeae* Town. reared on non-congeneric lepidopterous hosts, *Proc. Int. Society of Sugarcane Technology*, Vol. 14, 1972, 496-502.
- [4] GRENIER, S., Influence du superparasitisme sur la durée du développement larvaire et le poids du parasitoïde *Lixophaga diatraeae* élevé dans un hôte de substitution *Galleria mellonella*, *Entomol. Exp. Appl.* **29** (1981) 69-75.
- [5] KING, E.G., MILES, L.R., MARTIN, D.F., Some effects of superparasitism by *Lixophaga diatraeae* of sugar cane larvae in the laboratory, *Entomol. Exp. Appl.* **20** (1976) 261-269.
- [6] MINISTERIO DE LA AGRICULTURA, Cría y reproducción de *Lixophaga diatraeae* (Town.), NRAG 180, La Habana (1979).
- [7] BECKER, W.A., *Manual of Procedures in Quantitative Genetics*, 2nd edn, Washington State University, Washington, DC (1967).
- [8] KING, E.G., MARTIN, D.F., *Lixophaga diatraeae*: Development at different constant temperatures, *Environ. Entomol.* **4** (1975) 329-332.
- [9] GOICOECHEA, J.L., FRAGA, Y., PEREZ, A., Criterio de diferenciación sexual temprana en *Lixophaga diatraeae* (Town.) (Diptera:Tachinidae), *Biología (U.H.)* (1987).
- [10] KATZ, A.J., YOUNG, S.S.Y., Selection for high adult body weight in *Drosophila* populations with different structures, *Genetics* **81** (1975) 163-175.
- [11] MONTES, M., Estudios sobre la bionomía y la biometría de *Lixophaga diatraeae* (Town.), (Diptera:Tachinidae), *Ciencias, Ser. 4 Cienc. Biol.* **7** (1970).
- [12] PRUNA, P.M., CASTELLANOS, J.A., Estudios sobre *Lixophaga diatraeae*, *Ser. Biol. ACC* **47** (1973) 8-10.
- [13] WEISMANN, L., MONTES, M., Experimentos con *Lixophaga diatraeae*, *Poeyana Ser. A.* **42** (1967).

- [14] GRENIER, S., Développement endoparasitaire et croissance pondérale larvaire du parasitoïde *Lixophaga diatraeae* (Town.) (Dip.:Tachinidae) dans un hôte de substitution *Galleria mellonella* (Lep.:Pyralidae), *Entomophaga* **25** (1980) 17-26.
- [15] YAMADA, Y., The difference of pupa weight measurements in *Tribolium* and its effects on selection responses, *Can. J. Genet. Cytol.* **17** (1975) 601-607.
- [16] HOFFMANN, H., El tiempo de desarrollo de las larvas y pupas de *Lixophaga diatraeae* (Town.) en relación con la temperatura, *Rev. Peruana Entomol.* **14** (1971) 320-322.
- [17] ENGLERT, D.W.C., BELL, A.E., Selection for time of pupation in *Tribolium castaneum*, *Genetics* **64** (1970) 541-552.
- [18] BOLLER, E.F., KATSOYANNOS, B.I., REMUND, U., CHAMBERS, D.L., Measuring, monitoring and improving the quality of mass-reared Mediterranean fruit flies, *Ceratitidis capitata* Wied. 1. The RAPID quality control system for early warning, *Z. Angew. Entomol.* **92** (1981) 67-83.

**LETHAL EFFECTS OF RADIATION
(FOOD DISINFESTATION)**

(Session 6)

Chairman

S. BARBOSA

FAO

IRRADIATION AS A QUARANTINE TREATMENT FOR THE ORIENTAL FRUIT FLY, *Dacus dorsalis* Hendel, IN MANGOES

Puangpaka KOMSON*, Manon SUTANTAWONG**,
Eueychai SMITASIRI*, Chamlong LAPASATUKUL*,
Udorn UNAHAWUTTI*

* Department of Agriculture,
Ministry of Agriculture and Cooperatives,

** Office of Atomic Energy for Peace,
Bangkok, Thailand

Abstract

IRRADIATION AS A QUARANTINE TREATMENT FOR THE ORIENTAL FRUIT FLY, *Dacus dorsalis* Hendel, IN MANGOES.

The Oriental fruit fly, *Dacus dorsalis* Hendel, is well recognized as a serious pest that causes damage to various kinds of fruits. It not only causes enormous losses in production, but also poses quarantine problems and severely restricts the trade and movement of fresh fruits between countries. Irradiation is one of the measures which is considered to be applicable to plant quarantine treatment for fruit fly control. Use of gamma irradiation for disinfestation of the Oriental fruit fly in mangoes has been carried out in Thailand. The results showed that a dose of 150 Gy achieved better than the probit-9 level of mortality, based on the criterion of efficacy of non-emergence of adult insects when five day old *Dacus dorsalis* larvae were treated. When 138 538 larvae were irradiated at the same dose, only one adult insect was recovered, generating a mortality of 99.9993%. However, when the criterion of efficacy based on the non-formation of pupae was used, a percentage mortality of only 25.9484 was obtained.

INTRODUCTION

All agricultural countries are more or less concerned with the introduction of exotic organisms considered harmful to their agricultural systems. Plant protection laws and regulations are intended to prevent the introduction of many organisms which are specified as quarantine pests. Eradication is very difficult and costly. For example, the Mediterranean fruit fly has been found and eradicated 5 times in Florida and once in Texas at a cost of more than US \$ 10 million [1]. Cornwell reported that once an exotic species is established, quarantine surveys of pest abundance, distribution and jump spread require great efforts in containment campaigns that are initiated with a view to eradication [2].

TABLE I. EFFECT OF GAMMA IRRADIATION AT THE ABSORBED DOSE OF 150 GY ON 5 DAY OLD ORIENTAL FRUIT FLY LARVAE IN NANG KLANGWAN MANGOES

Trial	Control						Treated			
	No. of Fruit	No. of Insects		No. of Survivors per fruit		No. of Fruit	No. of Insects		No. of Survivors per fruit	
		pupae	adult	pupae	adult		Based on formation of pupae	Based on formation of adult	pupae	adults
I	124	27 423	24 117	221.2	194.5	496	109 715	96 472	100 823	1
II	84	9 515	6 400	184.7	76.2	336	62 059	25 603	21 541	0
III	84	2 139	1 322	25.5	15.7	336	8 568	5 275	9 089	0
IV	84	4 173	2 794	49.7	33.3	336	16 699	11 188	14 459	0
						Total	197 041	138 538	145 912	1

Therefore, importing countries permit entry of only pest-free commodities. In order to conform with the laws and regulations of importing countries, exporters must treat the commodities prior to shipping. Fruit flies (Diptera : Tephritidae) are the most important problem involved in exporting horticultural crops. Irradiation disinfestation has many of the characteristics of a good quarantine treatment [3]. It is an expected measure which is considered to be applicable to plant quarantine treatment for fruit fly control at its different developmental stages. An absorbed dose of 250 Gy has been suggested as an effective quarantine treatment for fresh fruits and vegetables against fruit flies [4]; it would also be effective against the mango seed weevil and delay ripening of mangoes [5].

METHODS

The experiment was conducted in the laboratory of the Agricultural Regulatory Division, Department of Agriculture, Bangkok, Thailand. Irradiation has been done at the Office of Atomic Energy for Peace, Bangkok. Nang Klangwan mangoes were used in this study. They were infested with the Oriental fruit fly by being placed in cages containing approximately 25 000 adult flies. Puncturing of the skin allowed the female flies to oviposit directly into the fruits for 6 hours (after Rigney, Ref. [6]). Infested fruits were packed in 31 x 47 x 10 cm cardboard boxes, 12 fruits per box, and kept in a controlled room temperature of $27 \pm 2^{\circ}\text{C}$ for 6 days in order to obtain 5 day old larvae before treatment. The 5 day old larvae were used in this study because many scientists reported that resistance of fruit flies to irradiation increases as flies develop [7-10, 11, 12]. Twenty per cent of infested fruits were used for control and 80% for treatments, which comprised irradiation at the minimum dose of 150 Gy by placing the fruits 103 cm from the cobalt-60 source. Dosimetry was carried out using a Fricke dosimeter. After treatment the fruits were placed directly on the shelves. The plastic boxes containing sand and sawdust were put underneath the shelves for pupation. The shelves and the plastic boxes were covered entirely with muslin cloth to prevent reinfestation. The treated fruits were kept in the controlled room temperature of $27 \pm 2^{\circ}\text{C}$ for 14 days. Examination was made by counting the pupae and the fruits were then kept for adult emergence.

RESULTS AND DISCUSSION

The results of this study showed that a dose of 150 Gy achieved better than the probit 9 level of mortality, based on

the criterion of efficacy of non-emergence of adult flies when 5 day old Dacus dorsalis larvae were treated. When 138538 larvae were irradiated at this dose only one adult fly was recovered (Table I), regenerating a mortality of 99.9993%. Balock et al. reported that a dosage of 100 Gy generally prevented immature stage fruit flies from developing into adults [13], while Prasad and Sethi reported that third instar maggots of Dacus dorsalis, when irradiated with 150 Gy, resulted in an adult emergence rate of about 41.50% [14]. The minimum dose of radiation obtained by Seo et al. to prevent the development of the adult Oriental fruit fly from irradiated eggs or larvae was 209 Gy, using a thickness of irradiated volume of 1.47 g/cm² [15]. He concluded that as the average density and thickness of the irradiated volume increased, the minimum dose of gamma radiation that prevents development of adult Oriental fruit flies from irradiated eggs or larvae also increased to compensate for the absorption by the additional mass about the center of the irradiated volume. The United States Department of Agriculture Fruit Fly Investigation Laboratory has determined 260 Gy to be the required dose to prevent adult emergence of the three species of fruit flies in Hawaii [16]. Ohta et al. suggested that an increase in the minimum absorbed dose higher than that determined using the probit 9 concept (i.e. 260 Gy) should be considered because when eggs are treated at 260 Gy, those larvae that do hatch may develop into third instar larvae, and their feeding may decrease the marketability of the fruits [11].

When the criterion of efficacy based on the non-formation of pupae was used, the result was that only 25.9484% mortality was achieved. Balock et al. reported that doses over 1000 Gy failed to prevent pupation [13].

ACKNOWLEDGEMENTS

This project was supported by the International Atomic Energy Agency under Research Contract No. 4278/RI/RB. Co-operation of the staff of the Fruit Fly Disinfestation Project, Agricultural Regulatory Division, Department of Agriculture and Office of Atomic Energy for Peace, Bangkok, is gratefully acknowledged.

REFERENCES

- [1] BURDITT, A.K., Jr., Food irradiation as a quarantine treatment of fruits. *Food Technol.* 36 11 (1982) 51.
- [2] CORNWELL, P.B., "Irradiation as a quarantine control measure", *Food Irradiation (Proc. Int. Symp. Karlsruhe, 1966)*, IAEA, Vienna (1966) 381-393.

- [3] BROWER, J.H., TILTON, E.W., "The potential of irradiation as a quarantine treatment for insect infesting stored - food commodities" Radiation Disinfestation of Food and Agricultural Products (MOY, J.H., Ed), Hawaii Institute of Tropical Agriculture and Human Resources, University of Hawaii at Manoa, Honolulu, Hawaii (1985) 75-86.
- [4] KADER, A.A., et al., Irradiation of plant products, COMMENTS from CAST 1 (1984).
- [5] THOMAS, P., RAHALKA, G.W., Disinfestation of fruit flies in mango by gamma irradiation, Curr. Sci. 44 (1975) 775.
- [6] RIGNEY, J.C., Laboratory infesting of oranges with Queensland fruit fly, J.Aust.Inst.Agric. Sci. 42 (1976) 67.
- [7] BALOCK, J.W., BURDITT, A.K., Jr., CHRISTENSON, L.D., Effects of gamma radiation on various stages of three fruit fly species, J.Econ.Entomol. 56 (1963) 42.
- [8] CAVALLORO, R., DELRIO, G., "Biological effect of gamma radiation on the life stages of two fruit fly species", Radionuclides in Ecosystems (Proc. Third National Symposium on Radioecology, Oak Ridge, Tennessee, 1971) (NELSON, D.J. Ed.), Oak Ridge (1971) 1180-1190.
- [9] BUGHIO, A.R., QURESHI, Z.A., MECCHI, A.K., Effect of gamma radiation on the larvae of Dacus zonatus (Saunders), S.U.Res. J. (Sci.Ser.) 6 (1972) 77.
- [10] MONOTO, E.C., BLANCO, L.R., Disinfestation of mangoes by gamma irradiation, J. Radioisotope Soc. Philippines 20 (1982) 52.
- [11] OHTA, A.T., KANESHIO, K.Y., KURIHARA, J.S., KANEGAWA, K.M., NAGAMINE, L.R., "Is the probit 9 security level appropriate for disinfestation using gamma radiation?", Radiation Disinfestation of Food and Agricultural Products (MOY, J.H., Ed.), Hawaii Institute of Tropical Agriculture and Human Resources, University of Hawaii at Manoa, Honolulu, Hawaii (1985) 111-115.
- [12] RIGNEY, J.C., WILLS, P.A., "Efficacy of gamma radiation as a quarantine treatment against Queensland fruit fly", Radiation Disinfestation of Food and Agricultural Products (MOY, J.H., Ed.), Hawaii Institute of Tropical Agriculture and Human Resources, University of Hawaii at Manoa, Honolulu, Hawaii (1985) 116-120.
- [13] BALOCK, J.W., BURDITT, A.K., Jr., SEO, S.T., AKAMINE, E.K., Gamma radiation as a quarantine treatment for Hawaiian fruit flies, J.Econ.Entomol. 59 (1966) 202.
- [14] PRASAD, H.H., SETHI, G.R., Effect of gamma radiation on the development of oriental fruit fly, Dacus dorsalis Hendel, Indian J.Entomol. 42 3 (1980) 505-507.

- [15] SEO, S.T., KOBAYASHI, R.M., CHAMBERS, D.L., DOLLAR, A.M., HANDOKA, M., Hawaiian fruit flies in papaya, bell pepper, and eggplant : Quarantine treatment with gamma irradiation, J. Econ. Entomol. 66 (1973) 937-99.
- [16] BURDITT, A.K., Jr., SEO, S.T., "Dose requirements for quarantine treatment of fruit flies with gamma radiation", Disinfestation of Fruit by Irradiation (Proc. Panel Honolulu, 1970), IAEA, Vienna (1971) 33.

**INTERET DE L'IRRADIATION
POUR LA DESTRUCTION DES NYMPHES
DIAPAUSANTES DE MINEUSE CERCLEE
(LEPIDOPTERE: LYONETIIDAE)**

P. DUCOM*, L.A. BUSCARLET**,
R. MEKDOUD*, J.-P. CUGIER***

- * Laboratoire national d'étude des techniques de
fumigation et de protection des denrées stockées,
Service de la protection des végétaux,
Ministère de l'agriculture,
Cenon
- ** Département de biologie,
CEA, Centre d'études nucléaires de Cadarache,
Saint-Paul-lez-Durance
- *** Service de la protection des végétaux,
Ministère de l'agriculture,
Montfavet
- France

Abstract-Résumé

USE OF IRRADIATION AS A MEANS OF DESTROYING DIAPAUSING NYMPHS OF THE
RINGED LEAF MINER (LEPIDOPTERA: LYONETIIDAE).

Different methods have been experimented with to destroy the diapausing nymphs of *Leucoptera malifoliella* O.G. Costa which may be found in consignments of apples destined for export. Results with dichlorvos were disappointing. Hydrogen phosphide leaves some nymphs alive at concentration-time (CT) values of 130 g·h/m³, the dose at which signs of phytotoxicity appear. Methyl bromide only destroys 80% of the nymphs at CT values of 290 g·h/m³, beyond which dose the quality of the fruit may be impaired. Combining carbon dioxide (20%) with methyl bromide improves the latter's effectiveness significantly; extrapolation of results from a preliminary test indicates total effectiveness at a level of 120 g·h/m³ of methyl bromide. In view of the lack of practical effectiveness of gases, a preliminary attempt at using gamma radiation was made, which showed that, for doses between 400 and 600 Gy, no emergence occurred. This result was confirmed the following year in three tests. Analysis of the results of these tests revealed variations in sensitivity related to the stage of development of the nymphs at the time of treatment. The lethal doses for nymphs of different ages will have to be determined.

INTERET DE L'IRRADIATION POUR LA DESTRUCTION DES NYMPHES DIAPAUSANTES
DE MINEUSE CERCLEE (LEPIDOPTERE: LYONETIIDAE).

Différentes méthodes sont expérimentées pour détruire les nymphes diapausantes de *Leucoptera malifoliella* O.G. Costa pouvant se trouver sur des lots de pommes destinées à l'exportation. Le dichlorvos se révèle décevant. Le phosphore d'hydrogène laisse survivre des nymphes pour des valeurs du produit concentration-temps (CT) de 130 g·h/m³, dose à laquelle des phénomènes de phytotoxicité

apparaissent. Le bromure de méthyle ne détruit que 80% des nymphes pour des CT de 290 g·h/m³, dose au-delà de laquelle il y a des risques pour la qualité des fruits. L'association du dioxyde de carbone (20%) au bromure de méthyle augmente beaucoup l'efficacité de celui-ci; une extrapolation des résultats à partir d'un essai préliminaire situerait l'efficacité totale à 120 g·h/m³ de bromure de méthyle. Devant le manque d'efficacité pratique des gaz, un premier essai d'utilisation de l'ionisation aux rayons gamma a montré que pour des doses comprises entre 400 et 600 Gy aucune émergence n'intervenait. Ce résultat a été confirmé l'année suivante dans trois essais. L'analyse des résultats de ces essais fait apparaître des variations de sensibilité en fonction du stade d'évolution des nymphes au moment du traitement. Les doses léthales des nymphes de différents âges devront être précisées.

1. INTRODUCTION

La mineuse cerclée des feuilles d'arbres fruitiers (*Leucoptera malifoliella* O.G. Costa) est considérée en France comme un ravageur secondaire. Ces pullulations, exceptionnelles et toujours très localisées, n'ont que très rarement une incidence économique pour les producteurs. Le respect de la faune auxiliaire rend généralement inutile toute intervention spécifique contre ce microlépidoptère [1].

En automne les larves de *L. malifoliella* cherchent un abri pour y tisser un cocon et se nymphoser avant l'hiver. La présence occasionnelle de ces cocons à l'œil ou dans la cavité pédonculaire de pommes Granny Smith ou de poires Passe Crassane destinées à l'exportation vers l'Amérique du Nord prend alors une grande importance économique. En effet, les autorités phytosanitaires américaines et canadiennes, voulant éviter l'introduction de *L. malifoliella* sur leur territoire, inspectent et refouillent tout lot de fruits hébergeant une chrysalide de mineuse cerclée.

A la demande des arboriculteurs, le Service de la protection des végétaux français, en accord avec les services américains concernés, a mis sur pied un système de contrôle des lots de fruits destinés à l'exportation afin d'éviter tout incident à l'arrivée des bateaux. Il s'agit de contrôles en vergers, en stations de conditionnement et à l'embarquement, nécessitant un personnel important; certains lots peuvent être refusés et les risques d'erreurs ne sont pas pour autant complètement écartés. Depuis 1982, nous recherchons donc une méthode de traitement des fruits après récolte:

- ne modifiant pas l'aspect, les qualités organoleptiques et la durée de conservation des fruits;
- laissant des taux de résidus conformes aux normes;
- assurant une efficacité quasi totale, pouvant aller jusqu'à une sécurité de quarantaine, à savoir 99,997% de mortalité.

Les expérimentations ont porté sur l'utilisation du dichlorvos, insecticide organophosphoré à tension de vapeur élevée ne laissant que peu de résidus, du phosphure d'hydrogène et du bromure de méthyle, gaz toxiques largement employés pour la désinsectisation de diverses denrées.

Devant les résultats décevants de ces méthodes, le recours à l'ionisation a été envisagé en 1986.

2. MATERIELS ET METHODES

2.1. Essai au dichlorvos

Après un trempage de 30 secondes dans une solution aqueuse à 1 ou à 2 g de dichlorvos par litre, et égouttage, les pommes infestées sont placées dans une enceinte à 25°C et 70% d'humidité relative jusqu'à apparition des adultes.

2.2. Essai au phosphore d'hydrogène

Les fumigations de cocons de *L. malifoliella* sur pommes ou sur feuilles sont réalisées dans des enceintes de 610 ou 210 L.

Les doses expérimentées sont de 0,66, 1,32, 1,90 et 2,85 g/m³. L'efficacité de la fumigation est mesurée par le produit concentration-temps exprimé en g·h/m³ [2]. Les mesures de concentration en phosphore d'hydrogène obtenu à partir de pilules de Phostoxin (Degesch) se font régulièrement pendant les 72 h de mise sous gaz par chromatographie en phase gazeuse ou à l'aide de tubes colorimétriques.

Les lots témoins et les lots traités sont ensuite conservés à 25°C et 70% d'humidité relative.

2.3. Essais au bromure de méthyle

Avec le bromure de méthyle seul, les différentes doses de gaz (7,5, 15, 30, 40, 60, 80 et 120 g/m³) sont introduites sous forme liquide dans des enceintes d'un mètre cube contenant les lots de feuilles ou de pommes hébergeant les cocons de *L. malifoliella*. Le gazage dure 2 ou 4 h.

Avec un mélange de bromure de méthyle et de dioxyde de carbone, les feuilles et écorces abritant les cocons sont placées dans des enceintes de 11 L où le taux de dioxyde de carbone est amené à 20%. L'injection du bromure de méthyle (10, 15, 20, 25, 30 et 35 g/m³) se fait sous forme gazeuse au moyen d'une seringue. Le temps de fumigation est de 2 h.

Pour ces deux types d'essais, les concentrations en bromure de méthyle sont mesurées par chromatographie en phase gazeuse ou par thermoconductivité. Après traitement, les différents lots restent à 25°C et 70% d'humidité relative jusqu'à apparition des papillons.

2.4. Essais d'ionisation par rayons gamma

2.4.1. Essai de 1986

Les cocons prélevés sur écorces sont irradiés le 10 mars dans des boîtes d'élevage au Centre d'études nucléaires de Cadarache. Le traitement ionisant des

insectes est effectué dans un ionisateur biologique de laboratoire IBL 337 (Oris) d'une capacité de 1,4 L délivrant 60 Gy/min. Le temps de séjour dans l'ionisateur détermine la dose appliquée. Celle-ci est répartie de façon homogène dans l'échantillon grâce à la géométrie des 6 sources «crayons» disposées de façon concentrique et au faible volume sous rayonnement.

Les doses appliquées lors de ce premier essai sont de 366, 610, 854, 1098 et 1342 Gy. Après traitement, les insectes séjournent jusqu'à apparition des adultes dans un local frais et aéré à une température relativement constante voisine de 15°C.

2.4.2. Essais de 1987

a) Essai «conditions commerciales» réalisé à Avignon avec des insectes provenant de la région toulousaine: les cocons, déposés sur des fruits conditionnés en carton, sont exposés à des doses de 150, 300, 500 et 1000 Gy le 8 mars par la Société Conservatome à Dagneux.

b) Essais «boîtes d'élevage»: deux essais ont été conduits selon un protocole similaire, l'un à Avignon avec des insectes de la région toulousaine, l'autre à Bordeaux avec des insectes de la région d'Agen. Les irradiations ont eu lieu le 8 mars au CEN de Cadarache pour l'essai Avignon aux doses de 118, 236, 473, 592 et 1006 Gy, et le 7 avril pour l'essai Bordeaux aux mêmes doses moins la dose 1006 Gy.

Après traitement pour ces trois essais, les cocons sont placés à 20°C et les émergences régulièrement dénombrées.

2.5. Méthode d'analyse des résultats

En raison de l'importante mortalité naturelle de *L. malifoliella* et de la difficulté de dénombrer exactement les cocons se présentant souvent en amas, la mortalité des nymphes soumises aux différents traitements est exprimée en pourcentage de réduction d'émergence par rapport au lot témoin.

TABLEAU I. POURCENTAGE DE REDUCTION D'EMERGENCE PAR RAPPORT AU TEMOIN DE NYMPHES DIAPAUSANTES DE *L. malifoliella* APRES TREMPAGE DANS UNE SOLUTION DE DICHLORVOS

Dose (g/L)	Nombre d'émergents	% de réduction d'émergence
Témoin	438	—
1	185	55,4
2	227	48,1

TABLEAU II. POURCENTAGE DE REDUCTION D'EMERGENCE PAR RAPPORT AU TEMOIN DE NYMPHES DIAPAUSANTES DE *L. malifoliella* SUR FEUILLES DE POMMIER APRES EXPOSITION AU PHOSPHURE D'HYDROGENE

Dose (g · h/m ³)	Nombre d'émergents	% de réduction d'émergence
Témoin	221	—
24,3	56	74,7
49,5	42	81
86	34	84,8

TABLEAU III. POURCENTAGE DE REDUCTION D'EMERGENCE PAR RAPPORT AU TEMOIN DE NYMPHES DIAPAUSANTES DE *L. malifoliella* SUR POMMES APRES EXPOSITION AU PHOSPHURE D'HYDROGENE

Dose (g · h/m ³)	Nombre d'émergents	% de réduction d'émergence
Témoin	877	—
30,6	200	77,2
61,7	161	81,5
102	59	93,2
134,2	27	96,9

L'analyse des résultats par régression linéaire des pourcentages de réduction d'émergence transformés en probits en fonction du log 10 [3] des doses expérimentées ne permet pas toujours un ajustement précis des valeurs calculées aux valeurs observées. Une diminution sensible des χ^2 d'ajustement est fréquemment obtenue en exprimant les doses dans une échelle «métamétrique» du type $y = x^\alpha$ où y est la dose transformée. La méthode consiste alors à chercher par approximations successives l'exposant α ($\alpha \in]0; 5[$) qui fournit le χ^2 minimum [4]. La pente et l'ordonnée à l'origine de la droite de régression sont enfin estimées par la méthode itérative décrite par Sokal [5] de maximisation de la fonction de vraisemblance.

TABLEAU IV. POURCENTAGE DE REDUCTION D'EMERGENCE PAR RAPPORT AU TEMOIN DE NYMPHES DIAPAUSANTES DE *L. malifoliella* SUR FEUILLES DE POMMIER APRES EXPOSITION AU BROMURE DE METHYLE

Dose (g·h/m ³)	Nombre d'émergents	% de réduction d'émergence
Témoin	221	—
15,2	213	3,6
26,3	137	38
51,6	175	20,8
67,6	119	46,2
107,1	131	40,7
143,2	125	43,4

TABLEAU V. POURCENTAGE DE REDUCTION D'EMERGENCE PAR RAPPORT AU TEMOIN DE NYMPHES DIAPAUSANTES DE *L. malifoliella* SUR POMMES APRES EXPOSITION AU BROMURE DE METHYLE

Dose (g·h/m ³)	Nombre d'émergents	% de réduction d'émergence
Témoin	1302	—
29	1099	15,6
57	1124	13,6
59	1082	16,9
76	1032	20,7
112	917	29,6
112	921	29,3
150	776	40,4
154	600	54
229	348	73,3
234	290	77,7
286	225	83

TABLEAU VI. POURCENTAGE DE REDUCTION D'EMERGENCE PAR RAPPORT AU TEMOIN DE NYMPHES DIAPAUSANTES DE *L. malifoliella* SUR FEUILLES ET ECORCES APRES EXPOSITION A UN MELANGE GAZEUX DE DIOXYDE DE CARBONE A 20% ET DE DOSES CROISSANTES DE BROMURE DE METHYLE

Dose (g·h/m ³)	Nombre d'émergents	% de réduction d'émergence
Témoin	1018	—
17,4	923	9,3
25,7	797	21,7
36,78	622	38,9
48,06	614	39,7
52,12	407	60
55,56	296	70,9

3. RESULTATS

3.1. Essai au dichlorvos

Les résultats du tableau I montrent que, malgré sa tension de vapeur élevée, le dichlorvos n'a que peu d'effet insecticide sur les nymphes diapausantes de *L. malifoliella*.

3.2. Essai au phosphore d'hydrogène

Les pourcentages de réduction d'émergence par rapport au témoin des lots traités figurent dans les tableaux II et III. Aucune des doses expérimentées ne permet d'approcher le pourcentage d'efficacité recherché.

3.3. Essais au bromure de méthyle

Le bromure de méthyle utilisé seul, même à des produits concentration-temps très élevés, ne conduit pas à des mortalités suffisamment importantes (tableaux IV et V).

Le mélange du bromure de méthyle avec du dioxyde de carbone permet d'améliorer l'efficacité de la fumigation (tableau VI). Cette augmentation de la sensibilité des insectes d'environ un facteur 2 est en accord avec de nombreuses autres études [6].

TABLEAU VII. POURCENTAGE DE REDUCTION D'EMERGENCE PAR RAPPORT AU TEMOIN DE NYMPHES DIAPAUSANTES DE *L. malifoliella* SUR POMMES EN CONDITIONS COMMERCIALES APRES EXPOSITION AUX RAYONS GAMMA

Dose (Gy)	Nombre d'émergents	% de réduction d'émergence
Témoin	778	—
150	6	99,2
300	1	99,9
500	0	100
1000	0	100

TABLEAU VIII. POURCENTAGE DE REDUCTION D'EMERGENCE PAR RAPPORT AU TEMOIN DE NYMPHES DIAPAUSANTES DE *L. malifoliella* SUR ECORCE APRES EXPOSITION AUX RAYONS GAMMA

Dose (Gy)	AVIGNON		BORDEAUX	
	Nombre d'émergents	% de réduction d'émergence	Nombre d'émergents	% de réduction d'émergence
Témoins	485	—	283	—
118	6	98,8	63	77,7
236	3	99,4	34	88
355	2	99,6	12	95,7
473	0	100	6	97,8
592	0	100	0	100
1006	0	100	—	—

3.4. Essais d'ionisation

L'expérimentation conduite en 1986 n'a permis l'observation que d'un seul papillon dans le lot 366 Gy, soit une réduction d'émergence par rapport au témoin de 99,6%.

Les résultats des expérimentations de 1987 figurent dans les tableaux VII et VIII.

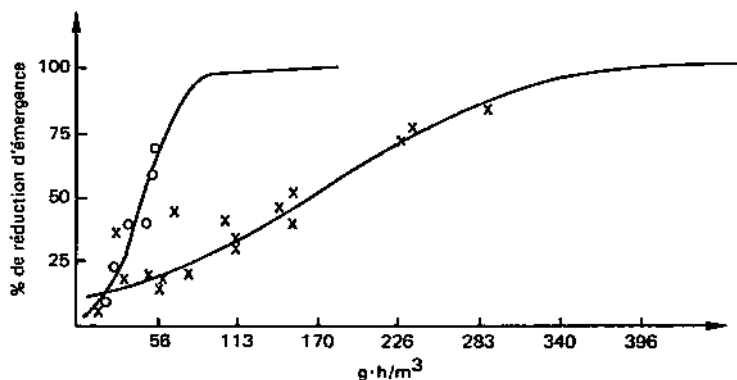

FIG. 1. Courbe calculée et valeurs observées de pourcentage de réduction d'émergence de nymphes diapausantes de *L. malifoliella* après traitement au bromure de méthyle (o: bromure de méthyle plus dioxyde de carbone; x: bromure de méthyle).

Sur l'ensemble des trois essais, aucune émergence n'intervient à partir de la dose 592 Gy.

La comparaison des deux essais «boîtes d'élevage» fait apparaître une sensibilité aux rayons apparemment moins grande pour la population de l'essai Bordeaux. Par ailleurs, aucun des papillons des essais «conditions commerciales» et «boîtes d'élevage» Avignon ne semblaient viables alors que, pour les doses 118 et 236 Gy de l'essai «boîtes d'élevage» Bordeaux, 76% et 20% respectivement des imagos étaient vivants au moment des comptages.

4. DISCUSSION

Parmi les méthodes expérimentées pour détruire les nymphes diapausantes de *L. malifoliella*, l'utilisation du dichlorvos et du phosphore d'hydrogène ne paraissent pas être des voies de recherche à poursuivre. Le dichlorvos n'a que peu d'effet sur des insectes en arrêt de développement protégés par un cocon. Pour le phosphore d'hydrogène, l'analyse des résultats indique que le CT donnant une efficacité de 99,997% serait de 188 g·h/m³; or, des altérations des pommes Granny Smith apparaissent dès un CT de 40 g·h/m³ [7].

Le bromure de méthyle permettrait d'obtenir une mortalité de 99,997% pour un CT de 480 g·h/m³; s'il était utilisé dans une atmosphère à 20% de dioxyde de carbone, cette même efficacité serait donnée par un CT de 120 g·h/m³ (fig. 1).

La phytotoxicité du bromure de méthyle sur la variété Granny Smith n'est pas connue précisément; les pommes Golden, réputées moins fragiles, supportent sans dommage un CT de 180 g·h/m³ [8]. Il ne paraît guère possible de dépasser cette valeur, ce qui exclut l'utilisation du bromure de méthyle seul. L'association bromure

TABLEAU IX. EMERGENCES DE *L. malifoliella* DANS LE TEMOIN, DANS LE LOT SOUMIS A UNE IRRADIATION DE 118 Gy ET EFFECTIFS CALCULES THEORIQUES DE CETTE MODALITE POUR L'ESSAI «BOITES D'ELEVAGE» BORDEAUX

Date Dose (Gy)	22/04	24/04	27/04	29/04	6/05	13/05	15/05 1/06
0	7	8	26	40	159	30	13
118	1	6	26	15	11	1	3
118 théorique	1,6	1,8	5,8	8,9	35,4	6,7	2,9

de méthyle et dioxyde de carbone devra faire l'objet d'autres expérimentations afin de vérifier l'efficacité d'un traitement à 120 g·h/m³ de bromure de méthyle sur des pommes Granny Smith en conditions commerciales.

Les deux années d'expérimentations préliminaires de destruction de nymphes diapausantes de mineuse cerclée à l'aide de rayons γ ne nous permettent pas de déterminer précisément la dose minimum au-delà de laquelle aucune émergence ne peut se produire. Pour l'essai de 1986, elle se situe entre 310 et 610 Gy; pour les essais de 1987, en «conditions commerciales» entre 300 et 500 Gy, en «boîtes d'élevage» Avignon entre 355 et 473 Gy, en «boîtes d'élevage» Bordeaux entre 473 et 592 Gy. L'ensemble de ces résultats fixerait la limite de 600 Gy comme étant une dose de sécurité. Aucun effet phytotoxique n'a été observé sur la variété Granny Smith pour des doses de 1000 Gy [9]. Les résultats des deux essais en «boîtes d'élevage» Avignon et Bordeaux sont apparemment contradictoires. Une comparaison par un test χ^2 d'homogénéité fait apparaître une différence très hautement significative entre la sensibilité des deux populations d'insectes aux mêmes doses d'irradiation. Ce fait ne semble pas devoir s'expliquer par la différence de provenance géographique des deux populations mais plutôt par l'écart entre les dates de traitement des deux essais, le 8 mars pour l'essai Avignon et le 7 avril pour l'essai Bordeaux. Les nymphes traitées précocement seraient plus sensibles aux rayons γ .

Cette hypothèse est d'ailleurs confirmée par l'analyse des dates d'émergence dans le lot témoin et dans le lot traité à 118 Gy de l'essai «boîtes d'élevage» Bordeaux (tableau IX). Un test χ^2 d'homogénéité fait en effet apparaître une différence très hautement significative entre la distribution des émergences dans le témoin et dans le lot traité. Les premières cohortes d'insectes sont sur-représentées dans ce dernier. Ce type d'analyse n'a pas pu être étendu aux autres doses et aux autres essais en raison des faibles effectifs d'imago, mais il est à noter cependant que, pour l'essai

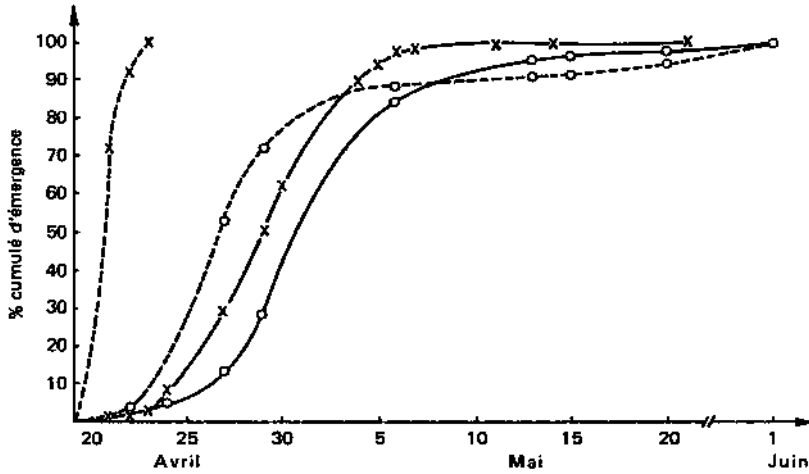

FIG. 2. Pourcentages cumulés d'émergence de *L. malifoliella* dans des lots témoins et dans les lots traités aux rayons γ en boîtes d'élevage (—o—: Bordeaux; —x—: Avignon).

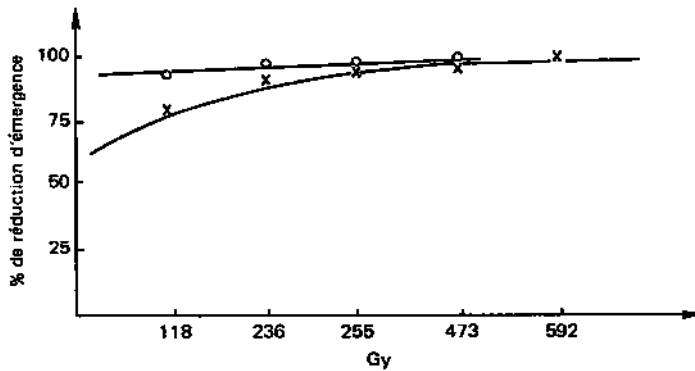

FIG. 3. Courbe calculée et valeurs observées de pourcentage de réduction d'émergence de nymphes diapausantes de *L. malifoliella* après exposition aux rayons γ en boîtes d'élevage (o: essai Avignon; x: essai Bordeaux).

«conditions commerciales» Avignon, les seules émergences observées dans les lots traités se sont produites lors du premier comptage. De même, pour l'essai «boîtes d'élevage» Avignon, la totalité des émergences des lots traités intervient lors des trois premiers comptages (fig. 2).

L'analyse statistique des résultats par la méthode des probits doit être interprétée prudemment, toutes les doses expérimentées se situant largement au-delà de la DL 50. Pour l'essai «boîtes d'élevage» Bordeaux, la DL 99,99 serait de 850 Gy et, pour l'essai «boîtes d'élevage» Avignon, de 520 Gy (fig. 3).

5. CONCLUSION

L'efficacité des gaz toxiques, phosphure d'hydrogène et bromure de méthyle, se manifeste au niveau recherché sur les nymphes diapausantes de mineuse cerclée à des doses provoquant l'apparition de phénomènes de phytotoxicité sur les fruits.

L'association bromure de méthyle et dioxyde de carbone pourrait être envisagée, sous réserve de vérifier son efficacité au niveau calculé de 120 g·h/m³ de bromure de méthyle et son absence de phytotoxicité sur la variété Granny Smith. En pratique, ce type de traitement devrait intervenir entre la récolte des fruits et leur mise au froid.

L'ionisation aux rayons γ à la dose de 600 Gy semble pouvoir détruire d'une manière sûre les nymphes diapausantes de *L. malifoliella*. La définition des doses léthales en fonction du stade d'évolution des nymphes doit faire l'objet de nouvelles expérimentations. Le traitement par ionisation pourrait s'inclure d'une manière souple en différents points du circuit commercial des fruits.

REFERENCES

- [1] BOUREAU, M., La mineuse cerclée des feuilles d'arbres fruitiers, *Phytoma* 339 (1982) 18.
- [2] MONRO, H.A.U., La fumigation en tant que traitement insecticide, FAO, Rome (1970), 398 p.
- [3] FINNEY, D.J., *Probit Analysis*, Cambridge University Press (1977) 333 p.
- [4] BOVA, F., LE GAT, Y., Service de la protection des végétaux, Bordeaux: communication personnelle (1987).
- [5] SOKAL, R.R., *Probit analysis on a digital computer*, *J. Econ. Entomol.* 51 5 (1958) 738.
- [6] Laboratoire national d'étude des techniques de fumigation et de protection des denrées stockées, non publié (1987).
- [7] PIERROT, R., LORQUIN, J., «Essai de fumigation de pommes Golden au bromure de méthyle», Service régional de la protection des végétaux, Toulouse (1980).
- [8] NAVARRO, S., DONAHAYE, E., «Sensitization of insects to fumigation techniques, including reduced pressure», *Proc. 4th Int. Work. Conf. Stored-Product Protection*, Tel Aviv (1986) 345.
- [9] Centre technique interprofessionnel des fruits et légumes, Paris: rapport interne (1987).

EFFECT OF GAMMA RADIATION TREATMENT ON THE MORTALITY OF THE FLOUR BEETLE

Z. ZARE, F. TOOFANIAN
Gamma Irradiation Center,
Atomic Energy Organization of Iran,
Tehran, Islamic Republic of Iran

Abstract

EFFECT OF GAMMA RADIATION TREATMENT ON THE MORTALITY OF THE FLOUR BEETLE.

Research has been carried out for many years on the disinfection of stored agricultural products. Recently, such investigations have been initiated at the Gamma Irradiation Center of the Atomic Energy Organization of Iran. The red flour beetle (*Tribolium confusum*) is the most common and most destructive pest of wheat, wheat flour and other stored grains in Iran. Different stages in the development of the red flour beetle were exposed to various doses of gamma radiation and the effects of the doses have been studied. A cobalt-60 source was used for irradiation. Five doses in the range of 0.1–1.5 kGy were used. The doses were delivered at a rate of 0.6 kGy/h. Insects were obtained from the northern regions of Iran and reared in an incubator in the laboratory. The research objectives included: (1) determining the doses of radiation required to destroy red flour beetles at their various stages of development; (2) determining the physical and chemical changes of wheat flour corresponding to the required dose level. In the paper, the radiosensitivity of various stages (larvae, pupae and adults) is discussed. At 0.1 and 0.25 kGy, the mortality rate increased in the range of 15 to 20 times more than that of the control group during the 20 d period. During one week, post-irradiation mortality rates of 15, 40 and 100% at 0.5, 1 and 1.5 kGy dose levels, respectively, were observed. The pupae were more sensitive than were larvae and adults. One hundred per cent mortality at 0.1, 0.25, 0.5, 1 and 1.5 kGy was observed at 23, 21, 19, 11 and 7 days post-irradiation. The lethal dose 50 (LD₅₀) obtained (8 d) at 30°C temperature was 1 kGy. Doses of 0.25 kGy sterilized the males and females, but at 0.10 kGy, mating took place and viable eggs were produced and hatched.

1. INTRODUCTION

Among several factors limiting crop production, insects play a significant economic role. All over the world insects constitute one of the most important hazards to stored grains. They have been estimated to destroy at least 5% of the world production of cereal grains. Tropical and subtropical climates, such as those found in Iran, Pakistan, Turkey, the Middle East and the Far East, are highly favourable to the growth and multiplication of stored grain insects [1].

The conventional methods of controlling these insects have varied between the age-old sun treatment all the way to modern insecticidal or fumigation methods. Fumigation, though by far the most effective method of grain disinfection, has its own serious limitations. The efficiency of application is governed by the physical factors of distribution and penetration of the fumigant into all parts of the grain. This

method is also subject to human errors as well as several other modifying factors. Then there are hazards of application, as well as the toxicity of residues left behind.

The development of resistance among insects through persistent application of chemical insecticides is yet another incentive to devise and develop a better method of grain disinfestation which will take care of basic control problems without leaving any toxic or poisonous residues [2]. At present, fumigation is the main method used for the destruction of insects infesting wheat in Iran.

The need for basic information on the effect of radiation on Iranian insect pests of economic importance has long been felt. The present work has the aim of exploring the basic effect of gamma radiation on the mortality of the flour beetle, which is one of the most common grain pests in Iran.

2. MATERIALS AND METHODS

The common grain pest in Iran is the red flour beetle (*Tribolium confusum*) and the adults of this insect were obtained from a heavily infested wheat flour sample that was supplied from Gilan Province (in the northern region of Iran). This sample also served as an experimental medium for rearing the insects [3]. All insect cultures obtained were kept in the incubator under a constant temperature of 29–30°C and at a relative humidity of 40%.

The experimental work was carried out in the laboratories of the Gamma Irradiation Center of the Atomic Energy Organization of Iran. A panoramic cobalt source with a dose rate of 0.6 kGy/h was utilized for radiation exposures. The dosimetry system utilized was the reference Fricke Chemical dosimeter.

Freshly hatched larvae, 24 h old adults and pupae were irradiated separately in groups of 20 insects at various dose levels in the range of 0.1–1.5 kGy [4]. For each treatment three replications were used; the control group was placed under the same conditions, except for irradiation. Daily counts of dead and living insects were made and changes in developmental and reproduction patterns were studied.

In order to evaluate the sterilizing dose for both the males and females, pupae were collected from the culture medium irradiated at doses in the range of 0.1–0.25 kGy. After irradiation, the adults were taken and paired in the following combinations [5]:

- (1) Irradiated male × normal female
- (2) Normal male × irradiated female
- (3) Irradiated male × irradiated female
- (4) Normal male × normal female.

For each mating combination three replications were used. The insects thus paired were kept in specimen tubes (8 cm × 2.5 cm) and wheat flour was added to serve both as food and as a medium for oviposition. The data obtained on mortality at the end of three weeks were subjected to analysis for calculation of T_{50} .

TABLE I. EFFECT OF GAMMA RADIATION ON THE CUMULATIVE PERCENTAGE OF MORTALITY OF *T. confusum* AS A FUNCTION OF TIME AFTER IRRADIATION

Different stages	Dose (kGy)	Cumulative percentage of mortality as a function of time (d)											T ₅₀ (d)	
		0	3	5	7	9	11	13	15	17	19	21		23
Adults	0	0	0	0	0	0	5	5	15	25	35	50	55	21
	0.1	0	0	0	0	5	20	36	46	70	85	85	100	15
	0.25	0	0	0	0	5	45	70	80	83	98	100	12	
	0.5	0	0	0	11	22	63	90	93	96	100		10	
	1.0	0	0	5	30	60	100						8	
	1.5	0	10	55	100								4	
Larvae	0	0	0	0	5	10	15	30	35	40	55	65	20	
	0.1	0	0	0	15	23	25	45	50	75	93	100	15	
	0.25	0	0	0	25	28	35	51	55	82	100		13	
	0.5	0	11	18	35	45	56	82	91	100			10	
	1.0	0	16	40	85	100							6	
	1.5	41	70	100										

3. RESULTS AND DISCUSSION

The effect of radiation on the different stages of development of *T. confusum* is expressed as the T₅₀, which is the time during which 50% of the irradiated population (adults and larvae) dies after exposure to a given dose of radiation [6, 7]. The results of different stages are indicated below.

3.1. Adults

From the results of Table I, it is seen that 100% mortality after exposure is obtained with a maximum radiation dosage of 1.5 kGy after 7 d. The minimum dose of 0.1 kGy resulted in a 100% death rate in 23 d. The results of T₅₀ for the different stages of development to gamma radiation are presented in Table I. In the case of adults at a maximum radiation dose of 1.5 kGy, the T₅₀ was 4 d; at a minimum radiation dose of 0.1 kGy the T₅₀ was 15 d.

TABLE II. EFFECT OF GAMMA RADIATION ON THE PUPAE OF *T. confusum* AFTER TWO WEEKS

Dose (kGy)	Adult emergence (%)	Mortality of adults (%)
0.00	95.0	8.30
0.10	75.00	55.50
0.25	41.60	80.00
0.50	33.30	100.00
1.00	0.00	—
1.50	0.00	—

3.2. Pupae

In general there was no emergence of pupae after doses of 1 kGy and above. Table II shows the percentage of adult emergence and mortality.

3.3 Larvae

Table I shows the results of the percentage of mortality and T_{50} . The 100% mortality at a dose of 1.5 kGy was observed to be 5 d, while the minimum dose of 0.1 kGy produced 100% mortality after 21 d. At doses of 1.5 and 0.1 kGy, the T_{50} was 3 and 15 d, respectively. At all other dose levels the larvae did not enter to the next instar and died.

The results of mating combination groups which were exposed to 0.1 kGy illustrated this phenomenon. In mating combination groups 2 and 3, the eggs were found to be sterile, but at the same dose of 0.1 kGy in a mating involving combination group 1 the eggs hatched and viability was observed. However, at 0.25 kGy, in mating combination groups 1-3, the eggs were found to be sterile. These data indicate that females can be sterilized at a dose of 0.1 kGy, while the sterilizing dose for the males is 0.25 kGy.

ACKNOWLEDGEMENTS

The authors wish to thank M. Sohrabpour, Director of the Gamma Irradiation Center, for his encouragement throughout the progress of this work. Special thanks are also due to A. Hadjinia for his help in sample irradiation.

REFERENCES

- [1] HUQUE, H., "Preliminary studies on irradiation of some common stored-grain insects in Pakistan", Radiation and Radioisotopes Applied to Insects of Agricultural Importance (Proc. Int. Symp. Athens, 1963), IAEA, Vienna (1963) 455-463.
- [2] NAIR, K.K., SUBRAMANYAM, G., "Effects of variable dose-rates on radiation damage in the rust-red flour beetle *Tribolium castaneum* Herbst", *ibid.*, pp. 425-430.
- [3] BROWN, G.A., DAVIS, R., Sensitivity of red flour beetle eggs to gamma radiation as influenced by treatment age and dose-rates, *J. Ga. Entomol. Soc.* 8 (1973) 153.
- [4] BUCKHOLD, B., SLATER, J.V., Effect of temperature and irradiation on pupae of flour beetle, *Tribolium confusum*, *Radiat. Res.* 37 (1969) 567.
- [5] EL-KADY, E.A., "Use of radiation disinfestation in the control of rice insect pests during storage", Combination Processes in Food Irradiation (Proc. Int. Symp. Colombo, 1980), IAEA, Vienna (1981) 229-241.
- [6] TILTON, E.W., BURKHOLDER, W.E., COGBURN, P.R., Effects of gamma radiation on *Rhyzopertha dominica*, *Sitophilus oryzae*, *Tribolium confusum* and *Lasiderma serricorne*, *J. Econ. Entomol.* 59 (1969) 1363.
- [7] BROWER, J.H., TILTON, E.W., Comparative gamma radiation sensitivity of *Tribolium madens* and *Tribolium castaneum* (Herbst), *J. Stored Prod. Res.* 9 (1973) 93.

STORED RICE WHOLESOMENESS AND THE CONTROL OF MITE AND PSOCID PESTS WITH GAMMA RADIATION

J. ZUSKA, Z. KUČEROVÁ
Research Institute of the Food Industry,
Prague

J. SEDLÁČKOVÁ
Nuclear Research Institute,
Řež

Czechoslovakia

Abstract

STORED RICE WHOLESOMENESS AND THE CONTROL OF MITE AND PSOCID PESTS WITH GAMMA RADIATION.

Experimental colonies of the mites *Acarus siro*, *Tyrophagus putrescentiae*, *Carpoglyphus lactis*, *Glycyphagus domesticus* and *Lepidoglyphus destructor*, and of a parthenogenetic psocid, *Liposcelis bostrichophilus*, were irradiated with a series of gamma ray doses from a ^{60}Co source. Changes in the population size within 35 d were measured. In *T. putrescentiae*, the growth of the population was not fully suppressed by doses within the range of 0.1 to 0.9 kGy. In *A. siro*, zero population growth was caused by doses of about 0.5 kGy, while in *C. lactis*, a dose of about 0.6 kGy caused zero population growth. In *G. domesticus* and *L. destructor*, neither the irradiated populations nor the controls showed a marked increase in the population. Colonies of all tested age groups of *L. bostrichophilus* (fourth instar nymphs and females of three age classes) stopped growing after irradiation at doses between 0.1 and 0.2 kGy. Sensory tests were also carried out on long grain Chinese rice irradiated at 0.2, 0.4 and 0.6 krad. No changes in colour were found. Flavour, and particularly taste, changed slightly after the 0.6 kGy treatment when tested one week after irradiation, but subsequent tests 1–12 months after irradiation did not show lowered sensory quality in any sample.

1. INTRODUCTION

In Czechoslovakia, rice consumption is fully covered by imports from abroad. While the amount of rice imported has remained essentially the same over the years, its provenance is changing. With the switch-over to new importers, some increase in the occurrence of insect and mite pests in imported milled rice has been detected.

Though the main pests intercepted are certain species of beetle, the ecological complex of the pests infesting rice is much wider, also including moths, psocids and mites. Their control is mainly based on chemicals. Naturally, it is most desirable to put into practice efficient, non-chemical methods of control. One of the possibilities is radiation disinfestation.

The technology of the radiation control of stored product pests is substantiated by numerous laboratory and operational studies. Unfortunately, the majority of published papers deal with beetles or, to a lesser extent, moths. Studies dealing with other insects, or with mites, are much more scarce. In addition, almost all of the authors have concentrated on the grain mite, *Acarus siro* [1-14], or the mould mite, *Tyrophagus putrescentiae* [10-11, 15-22]. Very few papers deal with other species of mites occurring in stored products [6, 11, 23, 24]. We have found no study of radiation effects on psocids in the literature.

Because published data often contradict one another, and more knowledge of radiation response is needed in many pest species, we decided to test susceptibility to gamma radiation in the grain mite, *Acarus siro* Linnaeus, 1758, and the mould mite, *Tyrophagus putrescentiae* (Schrank, 1781), of the family Acaridae; the dried fruit mite, *Carpoglyphus lactis* (Linnaeus, 1758), of the family Carpoqlyphidae; the domestic mite, *Glyphagus domesticus* (DeGeer, 1778) and *Lepidoglyphus destructor* (Schrank, 1781), of the family Glycyphagidae; and the psocid *Liposcelis bos-trichophilus* Badonnel, 1931, of the family Liposcelidae.

From the practical point of view, radiation control possibilities are determined not only by the susceptibility of pests, but also by the radiation induced changes in the properties of the commodity being protected. Chemical changes in rice caused by ionizing radiation were studied by a number of authors (see, e.g., Refs [25-27] and the references therein). Of course, a chemical analysis often appears to be less informative as to acceptability by consumers than organoleptic tests. We have therefore examined the sensory properties of irradiated rice one week after irradiation and then periodically up to one year thereafter. Our data should complement those of studies already published [26, 28].

2. MATERIALS AND METHODS

2.1. Pest population experiments

The response to irradiation was measured as the increase in the size of the irradiated population over a period of time. In all tests experimental colonies were established in a container with suitable food. These containers were then irradiated with a series of gamma ray doses and placed in standard temperature and air humidity conditions. After 35 d, the size of each population was compared with the starting size.

All mites and psocids were obtained from thriving laboratory cultures maintained at the Research Institute of the Food Industry, Prague. The stock colonies were kept on a wheat germ diet, except for *C. lactis*, which was fed with dried figs (see Table I for details of the experiment).

TABLE I. EXPERIMENTAL DETAILS OF PEST POPULATION STUDIES

Species	Food	Moisture in food (%)	
		On day of irradiation	35 d after irradiation
<i>A. siro</i> , test 1	Rice	16.2	16.1
<i>A. siro</i> , test 2	Rice	16.7	16.7
<i>T. putrescentiae</i>	Rice	17.1	— ^a
<i>C. lactis</i>	Rice + 2% dried apples	15.5	15.6
<i>G. domesticus</i>	Rice	16.8	16.1
<i>L. destructor</i>	Rice	16.0	16.1
<i>L. bostrichophilus</i> , all tests	Wheat germ	— ^a	— ^a

^a Not measured.

2.1.1. Mites

Test populations were kept in wide mouth, 250 mL polythene jars containing 100 g of rice. Prior to the start of each test, the rice was dried for several hours at 60°C to kill unwanted mites and then sprayed with a calculated amount of water in order for it to reach a moisture content level of about 16%, enclosed in a plastic bag for three days and mixed occasionally. The moisture content was determined gravimetrically at the beginning of each test. Mites removed from stock cultures (i.e. all developmental stages, including the eggs) were carefully, but thoroughly, mixed with a small amount of wheat flour; 2 mL of this mixture was put into each jar containing rice, which was then tightly closed with a very dense cloth fastened with firm rubber bands. The next day the jars with mites were irradiated with a series of gamma ray doses and then placed in darkness at 25°C and c. 85% relative humidity (RH). Four jars were treated with each dose. Three days after irradiation, two of these jars were removed and their contents were transferred to a Tullgren funnel to extract mites. After 24 h, the mites accumulated in the collecting vessel (i.e. all stages except for eggs and immobile hypopi) were counted. The mean number of individuals from all jars so treated, irrespective of the dose applied, was considered as the starting size of all experimental colonies. The immediate lethal effect of irradiation was very slight in *A. siro*. In other species there was no correlation between the dose and population size. The two remaining jars from each group were similarly examined 35 d after irradiation. The two population counts were merged for each dose. Along with

jars containing mites, a separate jar with rice, but without mites, was kept under the same conditions to allow the gravimetric determination of the final moisture content of rice on the termination of each test.

2.1.2. *Psocids*

Test colonies were started with a known number of individuals of the same instar and age. They were kept in wide mouth glass containers, 25 mm in diameter and 30 mm deep, closed with a rubber stopper with a cloth capped glass tube 4 mm in diameter in the centre and containing c. 0.5 g of wheat germ. Usually three containers, each with 20 individuals, were used for each dose. After irradiation, the containers were left in an environment of 25°C and c. 75% RH. The number of individuals was counted 35 d after radiation treatment (unless stated otherwise), but the colonies were checked regularly and notes on oviposition and egg hatch were made. Food moisture was neither manipulated nor measured.

2.2. Sensory evaluation of irradiated rice

Rice of Chinese origin, long grain type, extra grade, was used for sensory tests. Dry rice in 0.3 kg samples, closed in paper bags, was irradiated at doses of 0.2, 0.4 and 0.6 kGy and then stored, together with the unirradiated control, at laboratory temperature and air humidity. One week after irradiation, and again after 1, 2, 3, 4, 6 and 12 months, sensory tests were performed. They were carried out by a group of ten judges experienced in the sensory evaluation of rice at the facilities specifically furnished for organoleptic tests of food and under standardized test conditions. Samples which were to undergo testing were boiled in surplus tap water up to optimum tenderness and then successively served to judges without any flavouring. All samples, including a non-irradiated control, were labelled using number codes, but an additional non-irradiated sample was served as a known standard. Colour, taste and flavour were evaluated according to a five point 'hedonic' scale. The untreated standard was arbitrarily scored with five points in all three criteria. The final values were calculated as the arithmetic means of the scores by individual judges.

2.3. Irradiation

All irradiation treatments were performed at the Institute of Nuclear Research, Řež, using a ^{60}Co gamma source. As the tests with particular pest species and sensory evaluation tests were made successively, and the irradiator was replenished during this period, the dose rate differed considerably between the treatments. The extreme dose rate values in mite and psocid tests were 1.015 and 1.644 $\text{kGy}\cdot\text{h}^{-1}$, while rice for the sensory tests was irradiated at 0.945 $\text{kGy}\cdot\text{h}^{-1}$. Doses lower than 0.3 kGy were measured with Fricke dosimeters, while higher doses were calculated by extrapolation.

TABLE II. POPULATION GROWTH OF TESTED SPECIES (SIZE OF NON-IRRADIATED CONTROL POPULATION AFTER 35 d) AND EXPECTED GAMMA RADIATION DOSE CAUSING ZERO POPULATION GROWTH OVER THE 35 d PERIOD

Species	Population size of untreated control (% of starting population)	Dose preventing population increase (kGy)
<i>A. siro</i> , test 1	1387	0.50
<i>A. siro</i> , test 2	2261	0.54
<i>T. putrescentiae</i>	6872	0.80
<i>C. lactis</i>	1251	0.59
<i>G. domesticus</i>	116	—
<i>L. destructor</i>	51	—
<i>L. bostrichophilus</i> , nymphs ^a	2105	0.14
<i>L. bostrichophilus</i> , females 7 d old	435	0.09
<i>L. bostrichophilus</i> , females 17 d old	470	0.16
<i>L. bostrichophilus</i> , females 1-2 months old	787	0.12

^a Population size readings 73 d after irradiation.

3. RESULTS

As expected, some mite species were found to be rather resistant to gamma radiation (Figs 1 and 2). Although in *A. siro*, *T. putrescentiae* and *C. lactis* a dose of 0.2 kGy, or even less, clearly lowered the rate of the population increase, the growth of the population was fully inhibited by substantially higher doses (Table II). However, in *T. putrescentiae*, the colony always grew after irradiation with any dose up to 0.9 kGy, though the increase in the population was very slight in the samples irradiated at 0.36 kGy or more. The increase in the populations of *G. domesticus* and *L. destructor* was clearly fully inhibited by the lowest dose applied, 0.1 kGy.

The psocid *L. bostrichophilus* is undoubtedly a species which is rather sensitive to gamma radiation. A preliminary experiment showed that doses above 0.4 kGy drastically shortened the life of this otherwise rather long lived species (imaginal longevity at 25°C is c. five months) (Table III). Though our experiments were not aimed at finding exact sterilizing doses, our guesses of doses causing total sexual sterility, as derived from our observations, are summarized in Table IV. The results of four of our tests for increases in the population, as influenced by the irradiation dose, are

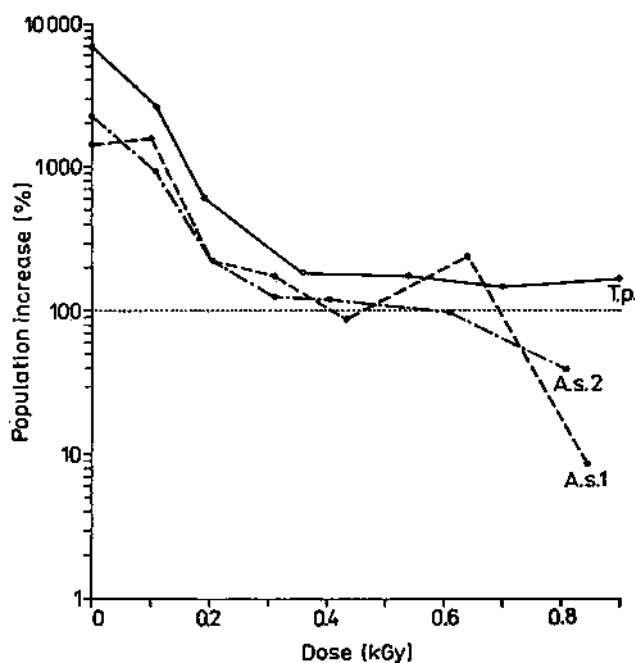

FIG. 1. Effect of gamma ray doses on population increase of mites. Population size is expressed as a percentage of the starting population 35 d after irradiation. T.p.: *T. putrescentiae*; A.s.1: *A. siro* test 1; A.s.2: *A. siro* test 2.

TABLE III. LETHAL AND STERILIZING EFFECTS OF GAMMA RADIATION ON 1-2 MONTH OLD ADULT *L. bostrichopilus* FEMALES

Dose (kGy)	Oviposition observed	Nymphs hatching	Colony size 30 d after irradiation (% of starting population)
0	+	+	815
0.10	+	+	120
0.21	+	-	86
0.31	+	-	60
0.43	+	-	— ^a
0.64	-	-	— ^b

^a Died out 28 d after irradiation.

^b Died out 12 d after irradiation.

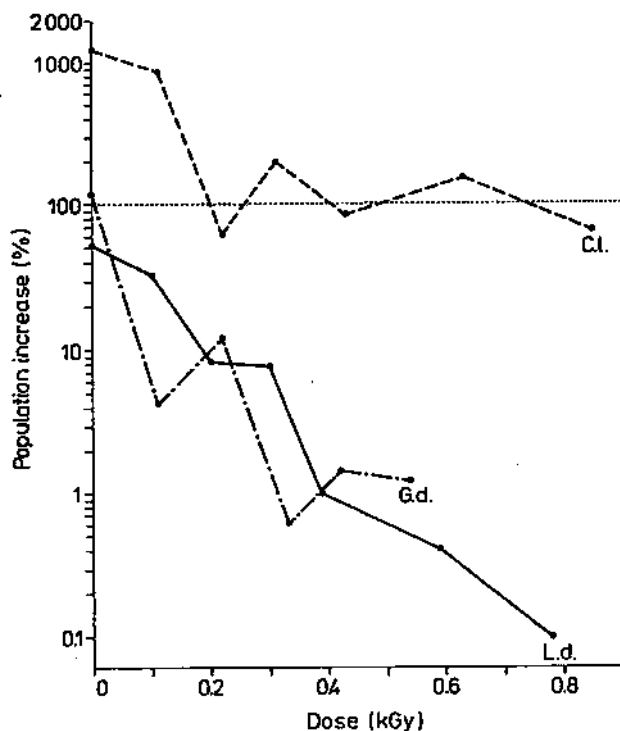

FIG. 2. Effect of gamma ray doses on population increase of mites. Population size is expressed as a percentage of the starting population 35 d after irradiation. C.l.: *C. lactis*; G.d.: *G. domesticus*; L.d.: *L. destructor*.

TABLE IV. PRELIMINARY VALUES OF STERILIZING DOSES OF GAMMA RADIATION FOR *L. bostrichophilus*

Stage	Instar or age	Minimum dose causing total sterilization (kGy)
Nymphs	Fourth instar	<0.1
Adult females	1-3 d	<0.16
	7 d	>0.16
	17 d	>0.2
	1-2 months	>0.2 ^a

^a Total sterilization at 0.2 kGy observed in one experiment.

TABLE V. SENSORY TEST SCORES ($\bar{x} \pm s_x$) FOR RICE SAMPLES IRRADIATED WITH GAMMA RAYS

Time elapsed after irradiation (months)	Dose (kGy)			
	0	0.2	0.4	0.6
	<i>Colour</i>			
0.25	5.0 ± 0.0	4.9 ± 0.4	5.0 ± 0.0	5.0 ± 0.0
1	5.0 ± 0.0	5.0 ± 0.0	4.9 ± 0.3	5.0 ± 0.0
2	4.9 ± 0.2	4.8 ± 0.4	4.8 ± 0.3	4.9 ± 0.3
3	5.0 ± 0.0	4.9 ± 0.2	5.0 ± 0.0	4.8 ± 0.4
4	5.0 ± 0.0	5.0 ± 0.0	4.8 ± 0.6	4.9 ± 0.3
6	5.0 ± 0.0	5.0 ± 0.0	5.0 ± 0.0	4.9 ± 0.3
12	5.0 ± 0.0	5.0 ± 0.0	5.0 ± 0.0	4.8 ± 0.5
	<i>Flavour</i>			
0.25	4.4 ± 1.0	4.0 ± 0.8	4.7 ± 0.5	3.4 ± 1.4
1	4.8 ± 0.4	4.7 ± 0.5	4.6 ± 0.5	4.6 ± 0.6
2	4.8 ± 0.4	4.3 ± 0.4	4.5 ± 0.7	4.6 ± 0.6
3	4.7 ± 0.4	4.8 ± 0.4	4.4 ± 0.7	4.1 ± 0.6
4	4.6 ± 0.5	4.6 ± 0.5	4.4 ± 0.7	4.5 ± 0.7
6	4.9 ± 0.3	4.8 ± 0.4	4.9 ± 0.2	4.8 ± 0.5
12	4.7 ± 0.5	4.6 ± 0.6	4.8 ± 0.5	4.7 ± 0.5
	<i>Taste</i>			
0.25	4.1 ± 0.9	4.0 ± 0.8	4.6 ± 0.5	3.1 ± 1.2
1	4.7 ± 0.4	4.7 ± 0.5	4.4 ± 0.5	4.5 ± 0.6
2	4.6 ± 0.6	4.0 ± 0.7	4.4 ± 0.7	4.4 ± 0.8
3	4.5 ± 0.7	4.6 ± 0.5	4.5 ± 0.6	4.2 ± 0.8
4	4.4 ± 0.6	4.5 ± 0.6	4.1 ± 0.7	4.7 ± 0.4
6	4.8 ± 0.4	4.5 ± 0.6	4.8 ± 0.4	4.3 ± 0.7
12	4.9 ± 0.2	4.8 ± 0.5	4.9 ± 0.2	4.9 ± 0.7

shown in Fig. 3. The populations of both fourth instar nymphs and adult females grew more slowly than did the unirradiated control population even if they were irradiated with doses much lower than 0.1 kGy. The zero population growth doses were quite low for all age groups (Table II).

The results of the organoleptic tests of irradiated rice are summarized in Table V. They show clearly that no changes in rice colour were found. Immediately after irradiation, flavour and taste were found to have scores somewhat lower in the 0.6 kGy sample than in the control sample and at lower doses, but one month after

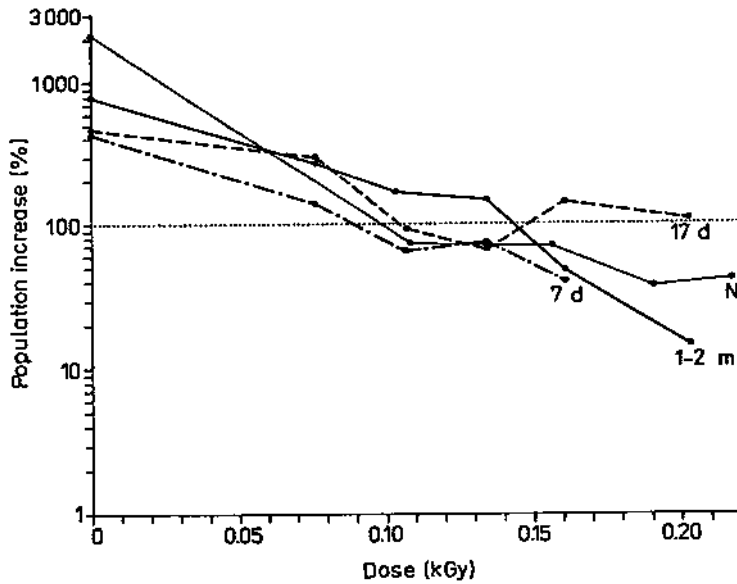

FIG. 3. Effect of gamma ray doses on population increase of the parthenogenetic psocid *L. bostrichophilus*. The population size is expressed as a percentage of the starting population 35 d after irradiation (in nymphs 73 d after irradiation). N: nymphs; 7 d: females 7 d old; 17 d: females 17 d old; 1-2 m: females 1-2 months old.

the treatment these differences disappeared. However, it is necessary to stress that even the samples with the lowest scores were still well above the acceptability limits of consumers.

4. DISCUSSION

It is well known that researchers seldom agree on the level of sterilizing and lethal doses of ionizing radiation for the same species. The diversity of these data is exemplified well by the literature on *T. putrescentiae*. Our results show that the rate of population increase of an irradiated colony is already slightly slowed at 0.1 kGy, but all doses examined (i.e. up to 0.9 kGy) apparently allow a certain degree of residual fertility in the treated population. We believe that our results are not caused by a mistake in our experiment, thereby permitting the reinfestation of the irradiated colony by the control or by individuals treated at low doses, but the data do contradict most published studies on this species. The doses which cause either sexual sterility or a decrease in the population vary as follows: 0.11-0.25 kGy [19], 0.4 kGy [18], 0.5 kGy [17], 0.6 kGy [10] or 0.4 kGy for males and 0.6 kGy for females [22].

Interestingly, the dose rate was found to exert a strong influence [20] when two radiation sources with activities of 523.4 Ci (1.936×10^{13} Bq) and 70.5 Ci (2.609×10^{12} Bq) were used. In the first case, 0.45 kGy was needed to sterilize adult mites, but in the second, weaker, source, 0.6–0.9 kGy was needed. It can be concluded that at least some strains of *T. putrescentiae* may be unusually radioresistant. The data on very high lethal doses for this species, 2–6 kGy [11, 15, 16], also indicate strong resistance.

Similarly, in *A. siro*, a dose of 0.2 kGy or less somewhat slowed down the rate of population increase, but a relatively high dose, approximating 0.5 kGy, stopped the development of the population. Again, the sterilizing dose, or the dose preventing an increase in the population, as given by various authors, varies extensively: 0.2 kGy [6], 0.4 kGy [7,10], 0.45 kGy [5] and 0.6 kGy [14]. A generalization can perhaps be made that a mixed population of *A. siro* would probably be suppressed at a dose of between 0.4 and 0.6 kGy.

There seem to be no data in the literature on *C. lactis* except for the lethal dose [11]. Because of its special nutritional requirements, this radioresistant species is expected to infest rice, but it is a common pest of dried fruits, which are most suitable for radiation disinfestation. We have therefore included it in this study.

The two glycyphagid species studied, *G. domesticus* and *L. destructor*, appear to be very sensitive to radiation. However, it is quite clear from the negligible increase, or even decrease, in the unirradiated control population that the rearing conditions were unsuitable. This stress, in combination with radiation, obviously resulted in a large decrease in the population (or, more precisely, in the conversion of a substantial part of the population into immobile hypopi) which did not reflect the true level of radiation sensitivity or resistance. Our results agree with those of Horák [6], who found that a dose of 0.15 kGy suppressed all stages of *Glycyphagus* sp.

Our experimental psocid species was *L. bostrichophilus*, which is parthenogenetic and may not fully represent the radiosensitivity of other synanthropic psocopterans. However, it is a common pest of a variety of commodities, including rice. Its economic importance is much underestimated. Our experiments showed that *L. bostrichophilus* is very sensitive to gamma radiation. It appears that any increase in the population can be fully inhibited by a dose of less than 0.2 kGy. Since very low doses are needed for sexual sterilization, radiation control of this species, and possibly of other psocids as well, might be technologically and economically very efficient. Further research on other psocids of economic importance is desirable.

For practical radiation control of stored products pests, a 'universal dose', of approximately 0.5 kGy, which can be used safely for the treatment of a wide range of commodities, has often been suggested in the belief that it can kill, sterilize, or cause other serious damage to the whole complex of pest species, except perhaps adult Lepidoptera. Certain published data mentioned above, and also some of our own results, indicate that this universal dose might be raised to 0.6 kGy, or perhaps 0.7 kGy, to also include noxious stored products mites.

However, it was shown that the development of irradiated mite populations is influenced by other life conditions as well, these synergizing factors often being of critical importance. Thus, in a study of a significant interaction between temperature and irradiation [13], temperature was found to be over 800 times more effective than irradiation in reducing the mite population. The decisive role of air humidity and/or food contained moisture for the survival of mite populations is well known. In an experiment with 25-kg lots of moistened rice containing colonies of *T. putrescentiae* and irradiated at various doses of gamma rays, population increases were recorded in the control group and in lots irradiated at low doses at the beginning of the experiment. However, later, after the rice gradually lost its surplus moisture, all of the colonies became nearly extinct [29]. In addition, it is known (e.g. in *T. putrescentiae* [20]) that those survivors of a radiation treatment who remain fertile often produce 'youngsters' whose offspring suffer from physiological or genetic defects. To summarize, for practical use the universal dose of 0.5 kGy cannot be challenged unless it can be shown to be too low in large scale field experiments or commercial disinfestation operations.

For rice, specifically, the occurrence of larger quantities of mites indicates the presence of an unwanted increase in water content. Mite control measures should always be preceded by rice drying. However, our results show that at least 0.6 kGy of gamma rays can be applied without the risk that the sensory qualities of the rice will be damaged, particularly if some time elapses between irradiation and consumption. Ismail et al., who tested two varieties of Egyptian rice immediately after irradiation, reported samples irradiated with 0.25 kGy or more with scores significantly lower than the control [26]. The acceptability limit, though, was 250 kGy. Japanese tests [28] with seven rice varieties indicated that samples irradiated at 0.5 kGy were graded lower than the untreated control immediately after irradiation, but, as in our own experiment, no significant differences in taste and flavour were found in subsequent tests.

ACKNOWLEDGEMENTS

We are very obliged to E. Žďárková of the Research Institute of the Food Industry, Prague, who very kindly supplied us with reliably identified live material of all tested mite species and helped us to plan our experiments and interpret their results. We thank E. Čadková and M. Reska of that institute for extensive technical help. J. Barvř of the State Institute of Food Quality Control, Prague, helped to organize the sensory evaluation of irradiated rice and agreed to use his institution's facilities for this purpose.

REFERENCES

- [1] MELVILLE, C., An apparent beneficial effect of gamma-radiation on the flour mite, *Nature* (London) **181** (1958) 1403-1404.

- [2] NICHOLAS, R.C., WIANT, D.E., Radiation of important grain-infesting pests: Order of death curves and survival values for the various metamorphic forms, *Food Technol.* **13** (1959) 58-62.
- [3] SZYSZKO, E., JAWORSKI, J., MLODECKI, H., BROSZKIEWICZ, R., Effect of low doses of X-rays on the grain mite (*Tyroglyphus farinae*), *Rocz. Panstw. Zakl. Hig.* **12** 6 (1961) 545-554 (in Polish).
- [4] SZYSZKO, E., WOZNIAK, J., MALESA, J., Effect of ionizing radiation on grain pests. II. Effect of radioactive cobalt radiation on the grain mite *Tyroglyphus farinae* L., *Rocz. Panstw. Zakl. Hig.* **13** 5 (1962) 493-501 (in Polish).
- [5] BURKHOLDER, W.E., TILTON, E.W., COGBURN, R.R., Effects of gamma radiation on the grain mite, *Acarus siro*, *J. Econ. Entomol.* **59** 4 (1966) 976-980.
- [6] HORÁK, E., Stored products disinfestation by cobalt radiation, *Mlýnsko-pekárenský Průmysl a Technika Skladování Obilí* **12** 3 (1966) 94-101 (in Czechoslovak).
- [7] DĄBROWSKI, Z.T., Sensitivity of the developmental stages of the grain mite (*Acarus siro* L.) to gamma radiation, *Rocz. Nauk. Roln. Ser. A.* **93** 4 (1968) 613-622 (in Polish).
- [8] BROWN, G.A., DAVIS, R., Effects of introduced irradiated male grain mites on population development, *J. Econ. Entomol.* **62** 4 (1969) 767-771.
- [9] BROWN, G.A., DAVIS, R., Sensitivity of grain mite eggs to gamma radiation as influenced by dose rate and treatment age, *J. Econ. Entomol.* **65** 6 (1972) 1619-1621.
- [10] KUZITOWICZ, Z., BEDNAREK, W., BACHMAN, S., Influence of ionizing radiation on *Acarus siro* L. and *Tyrophagus putrescentiae* (Schrank), *Zesz. Nauk. Probl. Postepow Roln.* **109** (1970) 257-261 (in Polish).
- [11] SHCHEGOLEVA, G.I., "Application of ionizing radiation for disinfestation of foodstuffs", *Proc. XIII Int. Congr. Entomol. Moscow, 1968, Vol. 2, Nauka, Leningrad* (1971) 36 (in Russian).
- [12] DAVIS, R., Some effects of relative humidity and gamma radiation on population development in *Acarus siro* L. (Acarina: Acaridae), *J. Ga. Entomol. Soc.* **7** 1 (1972) 57-63.
- [13] BANDITSING, C., HUNTER, P.E., Population development of *Acarus siro* reared at three temperatures following gamma irradiation, *J. Econ. Entomol.* **66** 1 (1973) 82-85.
- [14] JONCZY, J., Influence of ionizing radiation on reproduction and mortality of the flour mite (*Acarus siro* L.), *Folia Biol. (Warsaw)* **21** (1973) 77-84.
- [15] RUMYANTSEV, P.D., RATANOVA, V.F., Effect of ionizing radiation on grain mites, *Tr. Vses. Nauchno-Issled. Inst. Zerna Produkt. Pererab.* **35** (1958) 55-57 (in Russian).
- [16] SHCHEGOLEVA, G.I., Perspectives of ionizing radiation application for foodstuffs pest control, *Obezrazhivaniye zerna i zernokhranilishch* **41** (1963) 64-68 (in Russian).
- [17] FARKAS, J., Investigations into the radiation resistance of *Tribolium confusum* (Duval) and *Tyrophagus dimidiatus* (Herrmann), *Acta Biol. Hung.* **16** 3 (1966) 207-215.
- [18] CHMIELEWSKI, W., CZAPLICKI, E., GLOGOWSKI, K., Results of preliminary investigations to estimate lethal and sterilizing doses of Röntgen rays for *Tyrophagus putrescentiae* (Schrank) (Acarina: Acaridae), *Zesz. Nauk. Probl. Postepow Roln.* **109** (1970) 229-232 (in Polish).
- [19] ZAKLADNOI, G.A., Susceptibility of the mould mite to gamma radiation, *Tr. Vses. Nauchno-Issled. Inst. Zerna Produkt. Pererab.* **75** (1972) 54-61 (in Russian).
- [20] CZAJKOWSKA, B., BOCZEK, J., The influence of ionizing radiation on *Tyrophagus putrescentiae* (Schr.) (Acarida: Acaridae), *Zesz. Nauk. Probl. Postepow Roln.* **252** (1983) 29-47 (in Polish).
- [21] IGNATOWICZ, S., BOCZEK, J., DAVIS, R., BRUCE, W.A., Utilization of irradiated sperm from successive matings by the mold mite (Acari, Acaridae), *J. Econ. Entomol.* **76** 4 (1983) 683-686.

- [22] IGNATOWICZ, S., BOCZEK, J., "Effects of gamma radiation on the fertility of *Tyrophagus putrescentiae* (Schränk) (Acarida: Acaridae)" *Acarology* 6 (GRIFFITHS, D.A., BROWN, C.E., Eds), Vol. I, Ellis Horwood, Chichester, UK (1984) 457-463.
- [23] RUMYANTSEV, P.D., RATANOVA, V.F., BARTYSHEVA, A.P., Effect of ionizing radiation on the hypopus of the domestic mite, *Soobshch. Refer. Vses. Nauchno-Issled. Inst. Zerna Produkt. Pererab.* 5 (1958) 7-8 (in Russian).
- [24] SZYSZKO, E., WOZNIAK, J., GWIAZDOWSKI, S., JAWORSKI, J., Effect of ionizing radiation on grain pests. III. Effect of gamma radiation from radioactive cobalt-60 on *Cheyletus eruditus* (Schränk), *Rocz. Panstw. Zakł. Hig.* 13 6 (1962) 533-539 (in Polish).
- [25] TAJIMA, M., SEKIGUCHI, N., FUJIMAKI, M., The amino acid content in gamma-irradiated rice, *Agric. Biol. Chem.* 34 2 (1970) 319-320.
- [26] ISMAIL, F.A., EL-WAKEIL, F.A., EL-DASH, S.M., "Tolerance, quality and storability of gamma-irradiated Egyptian rice", *Food Preservation by Irradiation (Proc. Int. Symp. Wageningen, 1977)*, Vol. 1, IAEA, Vienna (1978) 501-515.
- [27] WACA, C.E., HARMS-RINGDAHL, M., Radiation-induced lipid peroxidation in whole grain rye, wheat and rice: Effect of linoleic and linolenic acids, *Radiat. Phys. Chem.* 28 3 (1986) 325-330.
- [28] Report of the Steering Committee on Food Irradiation, Atomic Energy Bureau, Science and Technology Agency, Tokyo (1984).
- [29] ZUSKA, J., ČADKOVÁ, E., Research Institute of the Food Industry, Prague, unpublished data.

COMBINATION OF GAMMA RADIATION AND ELEVATED TEMPERATURE AS A QUARANTINE TREATMENT AGAINST TWO PRINCIPAL STORED DATE INSECT SPECIES*

M.S.H. AHMED, A.A. AL-TAWEEL, A.A. HAMEED, H. AUDA
Faculty of Agriculture and Biology,
Nuclear Research Centre,
Baghdad, Iraq

Abstract

COMBINATION OF GAMMA RADIATION AND ELEVATED TEMPERATURE AS A QUARANTINE TREATMENT AGAINST TWO PRINCIPAL STORED DATE INSECT SPECIES.

Exposure of small, commercial polyethylene wrapped packages (carton boxes (CBs)) of dry dates to elevated temperature (40°C) for 48 or 72 h caused a significantly higher rate of insect mortality than did radiation or combination treatments. However, elevated temperatures alone neither exterminated all of the insects present in CBs nor induced complete sterility in them. The use of a combination treatment consisting of a 'low' gamma radiation dose and heat (0.35 kGy + 72 h at 40°C) proved to be a satisfactory method of disinfestation of CBs, since it has resulted in complete inhibition of adult emergence and pupation of last instar *Ephestia cautella* larvae. Using such a combination treatment brought about an approximately tenfold increase in the mean longevity of last instar *E. cautella* larvae, which could cause some additional damage in the treated date packages before the advent of their inevitable death. This phenomenon of life-span prolongation should be seriously taken into consideration when dealing with the quarantine regulations of different countries. It is interesting to note that one day after treatment, the effectiveness of the combination treatment of CBs was at its peak in comparison with the radiation treatment alone. This fact makes the combination treatment superior to other types of treatments which could be commercially utilized in the date trade, provided that date packages are always insect-tight to prevent reinfestation.

1. INTRODUCTION

Low dose gamma radiation has been proved to be a more effective method for insect disinfestation purposes of food and agricultural products than some suspected mutagenic and carcinogenic chemicals [1-3]. In this respect, many investigations were conducted in Iraq on dry date disinfestation using low doses of gamma radiation that did not exceed 1 kGy [4, 5], with special emphasis on packaging [6-8], since properly sealed polyethylene wrapping seemed to be more capable of preventing insect reinfestation after treatment than commercial cellophane. However, the range of the low doses of gamma radiation from a ⁶⁰Co source recommended [5] for insect

* This work is part of IAEA Research Agreement No. 2918/CF.

disinfestation purposes usually leads to life-span prolongation of late *Ephestia cautella* larvae that infest dry dates in Iraq [4, 9]. On the other hand, preliminary work showed that the longevity of this developmental stage, and that of *Oryzaephilus surinamensis* adults, detected in date fruits was significantly shorter when exposed to a combination treatment of gamma radiation and elevated temperature [8, 10]. Both radiation and the combination treatment resulted in efficient disinfestation of packed dates [4, 7, 8] that might even exceed the required quarantine security [11] of different importing countries, particularly in those circumstances where distribution of exported dates involves long shipping times. Practically, the purposeful application of two or more agents, i.e. a combination treatment, could bring about a reduction in the dosage of one or more factors that can be combined to produce a synergistic effect [4, 12], rendering the radiation disinfestation process more economical.

Therefore, the main objectives of the present investigation are as follows: (1) To find out the effect of combination treatments (0.7 kGy gamma radiation plus elevated temperature, 40°C for 48 and 72 h) on the disinfestation of deliberately infested commercial date packages wrapped with polyethylene foils instead of cellophane sheet to prevent reinfestation during storage. (2) To study the effect of a lower dose of radiation, 0.35 kGy, before exposure at 40°C for 72 h on disinfestation of dates as a more economical step than using a higher radiation dose. (3) To conduct some genetic or developmental tests on two principal stored date insect species found in the treated packages, or just exposed to some combination treatments. (4) To study the effect of some of the above mentioned treatments on the protein and amino acid composition of dry dates.

2. MATERIALS AND METHODS

2.1. Disinfestation of small, polyethylene wrapped date packages by combination treatment (0.7 kGy + 40°C for 48 h)

An approximate uniform distribution of a high infestation rate over all developmental stages of two principal stored date damaging insect species: *E. cautella*, 'Baghdad' (B), mating type [13] and *O. surinamensis* was obtained by placing 44 kg of 'Zahdi' variety dry dates from the latest harvest in four plexiglass cages which were infested in a manner similar to the method described in a previous work [6, 7]. After 45 d from the start of infestation, a sample of 4 kg of dates, taken from the four cages at random, was carefully examined. Out of 3241 insects at different stages of development found in this sample, 84% were alive. Such a percentage of live insects was taken as a measure of the effectiveness of the present method of date disinfestation, in addition to the radiation induced sterility. The dry date fruits that have been so infested were placed in 160 small carton boxes (CBs), known commercially as 'window carton lunch boxes', each holding 250 g of dry dates [7]. The same method was followed as that used in the Baghdad Packing House, Iraqi Date

Administration, except that the CBs were wrapped by hand with polyethylene sheets [6], instead of cellophane, using an electric heat sealer. Then, batches of 40 out of the 160 CBs were put into one standard carton box (SCB) each [14].

The four SCBs, with 40 CBs in each, were then treated as follows:

- (1) SCB No. 1: stored at 25°C and 40–60% relative humidity (RH) (the control).
- (2) SCB No. 2: stored at 40°C for 48 h (+ 2 h for thermal distribution) and then transferred to a 25°C environment.
- (3) SCB No. 3: date packages (40 CBs) have been treated with gamma radiation by placing two CBs at a time in a gamma cell-220 irradiation chamber with a ^{60}Co source having a dose rate of approximately 17.4 kGy·h⁻¹. The dose administered was 0.7 kGy at the central field of the chamber with a $D_{\text{max}}/D_{\text{min}}$ of c. 77/61=1.26, which is acceptable with regard to date disinfestation. This SCB was then stored at 25°C.
- (4) SCB No. 4: date packages were irradiated in a manner similar to SCB No. 3 and stored at 40°C for the same period, as was SCB No. 2, before transfer to a 25°C environment.

Examination of four CBs from each SCB took place approximately 1, 15, 30, 45, 75, 105, 135, 165, 205 and 235 d after treatment. The number and percentage of live insects per CB were recorded to assess the killing effect caused by the radiation dose, used alone or in combination with mild heat.

2.2. Disinfestation of date packages by treatment at 0.7 kGy + 40°C for 72 h

The same steps mentioned in the previous subsection were followed exactly, except that exposure at 40°C took place for 72 h instead of 48 h, and examination was carried out 1, 20, 35, 50, 70, 85, 95, 105, 120 and 140 d after treatment.

2.3. Disinfestation of date packages by treatment at 0.35 kGy + 40°C for 72 h

Following approximately the same methods of treatment stated above, examination of every four CBs was carried out at nine storage times: 1, 15, 30, 45, 60, 90, 120, 150 and 180 d after treatment.

2.4. Development and genetic tests

Details of the methods used to measure longevity, development capability and damaging activity of the immature stages and the fertility of adult insects of the two species, *E. cautella* and *O. surinamensis*, collected in some of the CBs after 24 h of post-treatment storage were mentioned in previous reports [7, 14].

An experiment was also carried out to measure the longevity and percentage of pupation of late *E. cautella* larvae treated, as stated in subsection 2.3., at 0.35 kGy + 40°C for 72 h and then transferred to a 25°C environment; non-irradiated larvae

were stored at 40°C for 72 h and at 25°C (control). In each treatment, about 60 larvae were used. After treatment, each larva was separately placed in a shell vial (25 mm × 75 mm) with c. 5 g of laboratory rearing medium, composed of 81% crushed wheat, 12% glycerin, 6% date syrup ('dibis') and 1% dry yeast by weight. All 240 vials, each with a single larva, were transferred to an incubator set at approximately 25 ± 1°C and 40–60% RH. Each larva was subjected to daily examination to see whether it pupated or died to assess the prolongation of larval longevity only and to assess the percentage of pupation for each treatment. In rearing and testing the larvae certain precautions were followed against an egg eater mite, *Blattisocius tarsalis* (Berlese) (Ascidae) (which is frequently found in date stores in Iraq), as determined by the Commonwealth Institute of Entomology, British Museum (Natural History).

2.5. Biochemical analysis of packed dates after treatment

Samples of CBs, treated as mentioned in subsection 2.1, were analysed to measure changes in protein and amino acid content according to the methods described earlier [15].

3. RESULTS AND DISCUSSION

3.1. Disinfestation of CBs at 0.7 kGy + 40°C for 48 h

Table I shows the percentages of live insects detected in four CBs filled with artificially infested dates when treated with gamma radiation or the combination treatment. The effect of exposure at 40°C for 48 h was obvious, especially when the CBs were examined directly (one day) after treatment, when the percentage of live insects (14.76%) was significantly lower than that resulting from any other type of treatment, including the combination treatment of 0.7 kGy + 40°C for 48 h, the percentage of which was 29.12 (Table I). However, treatment with mild heat (40°C) only did not cause the extermination of all live insects that were fertile and gave rise to a rather high percentage of infestation after 105 d of storage. Treatment at 0.7 kGy + 40°C for 48 h, on the other hand, resulted in more effective disinfestation and left no fertile insects starting from the first storage period. Only one live insect, an *O. surinamensis* adult, was detected in a slightly torn package that was stored for 135 d after such a treatment, indicating a case of reinfestation (Table I). It is interesting to note that one day after treatment, the effectiveness of the combination treatment was at its peak in comparison with treatment at 0.7 kGy only. This fact makes the combination treatment superior to the other types of treatments which could be commercially utilized in the date trade, provided that packages are always insect-tight to prevent reinfestation [16].

TABLE I. PERCENTAGE OF LIVE INSECTS FOUND IN FOUR CBs OF ARTIFICIALLY INFESTED DATES WHEN TREATED WITH GAMMA RADIATION OR COMBINATION TREATMENTS FOR 48 h

Type of treatment	Percentage of live insects found in treated date packages after the following storage periods (d)									
	1	15	30	45	75	105	135	165	205	235
25°C	69.21 ^a	25.99 ^a	31.67 ^a	44.94 ^a	77.20 ^a	—	—	—	—	—
40°C	14.76 ^c	8.54 ^a	5.24 ^b	20.84 ^b	17.07 ^b	54.23 ^a	—	—	—	—
0.7 kGy	96.78 ^a	5.99 ^b	0.00 ^b	0.00 ^c	0.00 ^b	0.00 ^b	0.00 ^a	0.0	0.0	0.0
0.7 kGy + 48°C for 48 h	29.12 ^b	4.81 ^b	0.00 ^b	0.00 ^c	0.00 ^b	0.00 ^b	1.25 ^a	0.0	0.0	0.0

Note: Means within a column followed by the same superscript letter are not significantly different at the 5% level using Duncan's Multiple Range Test.

Dashes indicate packages that were not examined owing to high infestation rate.

3.2. Disinfestation at 0.7 kGy + 40°C for 72 h

Table II shows the same phenomenon of the superiority of the combination treatment for disinfestation and the surprising, initially high, killing effect of exposure at 40°C alone, exceeding the effect of post-irradiation exposure to such a temperature. However, these effects appear more pronounced in this table than in Table I, since exposure to the mild temperature (40°C) lasted for 72 h instead of 48 h. Once again, the effectiveness of post-irradiation treatment at 40°C was evident at earlier stages of storage (cf. first and second columns of Table II). Such a combination treatment will be of use if disinfestation of date packages is required during a short period of storage, since it provides a more or less total killing ability of all live insects and ensures the sterility of any insect that might be detected alive after treatment.

3.3. Disinfestation at 0.35 kGy + 40°C for 72 h

Table III shows the percentages of live insects detected in every storage period in four CBs, examined after exposure to a somewhat low ⁶⁰Co gamma radiation dose or a combination treatment (0.35 kGy + 40°C for 72 h). Treatment at 40°C again only led, as shown in Tables I and II, to a significant decrease in the percentage of live insects (3.19%) one day after exposure in comparison with the other three types of treatments, including the results of the combination treatment (15.47%), as

TABLE II. PERCENTAGE OF LIVE INSECTS FOUND IN FOUR CBs OF ARTIFICIALLY INFESTED DATES WHEN TREATED WITH GAMMA RADIATION OR COMBINATION TREATMENTS FOR 72 h

Type of treatment	Percentage of live insects found in treated date packages after the following storage periods (d)									
	1	20	35	50	70	85	95	105	120	140
25°C	70.11 ^b	74.55 ^a	22.13 ^a	89.60 ^a	—	—	—	—	—	—
40°C	7.83 ^c	2.57 ^b	13.13 ^a	4.78 ^b	36.52 ^a	24.77 ^a	6.86 ^a	71.90 ^a	16.56 ^a	38.75 ^a
0.7 kGy	93.39 ^a	2.01 ^b	0.23 ^a	0.0 ^b	0.0 ^b	0.0 ^b	0.0 ^a	0.0 ^b	0.0 ^a	0.0 ^b
0.7 kGy + 40°C for 72 h	14.51 ^c	0.74 ^b	0.0 ^a	0.0 ^b	0.0 ^b	0.0 ^b	0.0 ^a	0.0 ^b	0.0 ^a	0.0 ^b

Note: See Table I for explanation of superscript letters and dashes.

TABLE III. PERCENTAGE OF LIVE INSECTS FOUND IN FOUR CBs OF ARTIFICIALLY INFESTED ZAHDI VARIETY DATES EXAMINED AFTER EXPOSURE TO A LOW GAMMA RADIATION DOSE OR A COMBINATION TREATMENT (0.35 kGy + 40°C FOR 72 h)

Type of treatment	Percentage of live insects found in treated date packages after the following storage periods (d)								
	1	15	30	45	60	90	120	150	180
25°C	94.27 ^a	28.66 ^a	37.29 ^a	59.41 ^a	47.42 ^a	70.15 ^a	—	—	—
40°C	3.19 ^c	0.15 ^b	0.0 ^b	6.46 ^b	20.23 ^a	15.04 ^b	8.51 ^a	6.88 ^a	31.82 ^a
0.35 kGy	87.13 ^a	3.81 ^b	3.28 ^b	1.55 ^b	1.25 ^b	10.16 ^b	0.0 ^a	0.0 ^a	0.0 ^a
0.35 kGy + 40°C for 48 h	15.47 ^b	1.48 ^b	0.58 ^b	0.92 ^b	0.0 ^b	0.16 ^b	0.0 ^a	0.0 ^a	0.0 ^a

Note: See Table I for explanation of superscript letters and dashes.

though radiation temporarily protected insects against heat injuries. However, the effect of the elevated temperature alone was invariably neither enough to exterminate all insects present in the dates nor induce complete sterility in them (Table IV). Consequently, a gradually higher percentage of infestation was restored in CBs kept at 40°C only.

TABLE IV. FERTILITY TESTS OF *E. cautella* ADULTS DEVELOPED FROM PUPAE, OR LARVAE FOUND IN DATE PACKAGES THAT WERE EXPOSED TO DIFFERENT TYPES OF TREATMENTS (NO ADULTS WERE OBTAINED FROM TREATMENT AT 0.35 kGy+40°C FOR 72 h)

Type of treatment	Male or female × opposite sex of B crossing type			
	No. of adults tested	No. of eggs laid	Per cent hatch	No. of spermatozoa/female
25°C (control)	20	2348	68.39 ^a	1
40°C for 72 h	1	80	55.00 ^a	1
0.35 kGy	3	289	0.00 ^b	1

Note: See Table I for explanation of superscript letters.

TABLE V. FERTILITY AND APPROXIMATE LONGEVITY OF *O. surinamensis* ADULTS FOUND IN DATE PACKAGES ONE DAY AFTER TREATMENT (USING WHEAT FLOUR AS A MEDIUM)

Type of treatment	No. of adults tested	Longevity (d)	Progeny (F ₁)		
			No. of		
			Eggs	Larvae	Pupae
25°C (control)	96*	56.00 ^a	150	180	26
40°C for 72 h	8*	56.00 ^a	25	8	8
0.35 kGy	176	7.48 ^b	Nil	Nil	Nil
0.35 kGy+40°C for 72 h	48	4.81 ^c	Nil	Nil	Nil

* All adults were discarded after 56 d, a period which was regarded in this table as their longevity for the sake of comparison and statistical analysis. However, according to our previous studies, *O. surinamensis* adults generally live for much longer than four months.

Note: See Table I for explanation of superscript letters.

TABLE VI. LONGEVITY OF *E. cautella* LAST INSTAR LARVAE FOUND IN DATE PACKAGES ONE DAY AFTER TREATMENT, AND THE TOTAL NUMBER OF PUPAE WITH THE PERCENTAGES OF ADULT EMERGENCE

Type of treatment	No. of larvae tested	Larval longevity (d)	Total No. of pupae found	Adult emergence (%)
0.35 kGy	34	29.31 ^a	18	16.67 ^b
0.35 kGy + 40°C	33	16.09 ^b	36	0.00 ^c
40°C for 72 h	5	4.60 ^c	50	4.00 ^c
25°C	—	—	45	80.00 ^a

Note: See Table I for explanation of superscript letters.

Although some *O. surinamensis* adults were detected in two torn packages after 90 d of storage in both irradiated batches (seventh column in Table III), the combination treatment was generally a more efficient method of date disinfestation throughout the nine long storage periods. However, the effectiveness of the current combination treatment of such a low dose (0.35 kGy + 40°C for 72 h) was evident one day after treatment in comparison with exposure to radiation alone.

3.4. Development and genetic tests

As described in Tables IV and V, exposure at 40°C for 72 h did not bring about any level of genetic sterility in *E. cautella* or *O. surinamensis*. However, using 0.35 kGy with or without post-irradiation exposure at 40°C caused complete sterility in both species. Also, such a low radiation dose and combination treatment resulted in a conspicuous and statistically significant reduction in the longevity of *O. surinamensis* adults (Table V).

Table VI shows that exposure at 40°C for 72 h resulted in a significant decrease in larval longevity (4.6 d) even when compared with the longevity of *E. cautella* larvae (16.09 d) found in CBs that were exposed to the combination treatment. In contrast, adult emergence was 4% in the former and 0% in the latter (Table VI). As for treatment at 0.35 kGy, only 16.67% adult emergence was recorded, with the adults, on mating, exhibiting complete sterility (Table IV), although the number of *E. cautella* (B strain [13]) adults found and tested was too small to reach a final conclusion. However, it seems that the utilization of the combination treatment of a relatively low gamma radiation dose and mild heat (0.35 kGy + 40°C for 72 h) for date packages is an efficient method of insect disinfestation that could be made more economical by lowering the ⁶⁰Co gamma radiation dose required or the present highly

TABLE VII. EFFECTS OF GAMMA RADIATION (0.35 kGy), ELEVATED TEMPERATURE (40°C FOR 72 h) AND COMBINATION TREATMENT ON THE LONGEVITY AND PUPATION OF *E. cautella* LAST INSTAR LARVAE

Type of treatment	No. of larvae tested	Larval longevity (d)		No. of larvae pupated	Pupation (%)
		Range	Mean±SD		
25°C (control)	58	1-5	2.02±1.03 ^b	52	89.65 ^a
40°C for 72 h, then transferred to 25°C	60	2-9	4.15±1.38 ^b	28	46.67 ^b
0.35 kGy at 25°C	60	1-50	22.35±14.53 ^a	14	23.33 ^c
0.35 kGy+40°C for 72 h, then to 25°C	60	3-55	19.48±15.15 ^a	0	0.00 ^d

Note: See Table I for explanation of superscript letters.

TABLE VIII. EFFECTS OF A LOW GAMMA RADIATION DISINFESTING DOSE AND COMBINATION TREATMENT (0.35 kGy AT 40°C FOR 72 h) ON THE DATE DAMAGING ABILITY OF LAST INSTAR *E. cautella* LARVAE (50 SOUND DATES + 30 LARVAE PER TREATMENT, AVERAGE OF 4-8 REPLICATES EXAMINED 45 d AFTER TREATMENT)

Type of treatment	No. of dates		Percentage of infested dates	Remarks
	Infested	Uninfested		
25°C (control 1)	177	23	88.5 ^a	
40°C for 72 h	116	84	58.0 ^b	
0.35 kGy+25°C	76	124	38.5 ^b	
0.35 kGy+40°C	128	272	32.0 ^c	
25°C (control 2)	22	178	11.0 ^d	No larvae added

Note: See Table I for explanation of superscript letters.

TABLE IX. PROTEIN CONTENT (PERCENTAGE FRESH WEIGHT) OF DATES EXPOSED TO A COMBINATION TREATMENT

Dose (kGy)	25°C	40°C for 48 h
0	1.57	1.31
0.7	1.66	1.58

TABLE X. TOTAL AMINO ACID CONTENT (mg/g FRESH WEIGHT) IN DATES EXPOSED TO A COMBINATION TREATMENT

Dose (kGy)	25°C	40°C for 48 h
0	10.27	9.53
0.7	10.51	9.28

radioresistant stored date insect species [4]. However, in order to comply with the current quarantine regulations of different countries, the implications of life-span prolongations of, for instance, last instar *E. cautella* larvae, which might increase tenfold over the control after irradiation or combination treatment (Table VII), thus causing a certain amount of damage to the dates (Table VIII), should be taken into consideration. To satisfy such regulations, higher doses (>0.7 kGy) should be administered, which might considerably increase the cost of date disinfestation. Therefore, it is thought necessary to bring about some relevant amendments in the respective quarantine requirements for irradiated dates.

3.5. Biochemical analysis of packed dates after treatment

The results of the biochemical analysis of some packed dates show that proteins are stable at a dose of 0.7 kGy + 40°C for 48 h (Table IX). This is in agreement with the previously mentioned data [7, 15] concerning other doses in combination treatments.

Analysis of 17 major amino acids showed that total amino acid content (Table X), after exposing date packages to such a combination treatment, is also not significantly different from the control. Such results confirm the already stated [5, 15] wholesomeness of irradiated and combination treated dry dates.

ACKNOWLEDGEMENTS

The technical assistance of K.D. Anber, S.B. Hussain and J.E. Shallal is gratefully acknowledged.

REFERENCES

- [1] Workshop on Low-Dose Irradiation Treatment of Agricultural Commodities, United States DOE/USDA/AIBS, Washington, DC (1982).
- [2] INTERNATIONAL FACILITY FOR FOOD IRRADIATION TECHNOLOGY, Fourth General Training Course on Food Irradiation, Wageningen, 1982.
- [3] Food Irradiation Processing (Proc. Int. Symp. Washington, DC, 1985), IAEA, Vienna (1985).
- [4] AHMED, M.S.H., Investigations on insect disinfestation of dried dates by using gamma radiation, *Date Palm J.* 1 1 (1981) 107.
- [5] WORLD HEALTH ORGANIZATION, Wholesomeness of Irradiated Food, Technical Reports Series No. 659, WHO, Geneva (1981).
- [6] AHMED, M.S.H., et al., Comparative evaluation of trial shipments of fumigated and radiation disinfested dates from Iraq, *Acta Aliment.* 14 4 (1985) 355.
- [7] AHMED, M.S.H., AUDA, H., AL-TAWEEL, A.A., HAMEED, A.A., Pilot Scale Radiation Disinfestation of Dry Dates with Emphasis on Packaging, Final Report, IAEA-Iraq Research Agreement No. 2918, Baghdad (1986).
- [8] AHMED, M.S.H., HAMEED, A.A., KADHUM, A.A., Disinfestation of commercially packed dates by a combination treatment, *Acta Aliment.* 15 3 (1986) 221.
- [9] AHMED, M.S.H., OUDA, N.A., LAMOOZA, S.B., AL-HAKKAK, Z.S., AL-SAQUR, A.M., "Disinfestation of dry dates by gamma radiation", Proc. 1st Sci. Conf., Scientific Research Foundation, Dar Alhuriya Press, Baghdad (1972) 264.
- [10] AHMED, M.S.H., AL-HAKKAK, Z.S., AL-MALIKY, S.K., KADHUM, A.A., LAMOOZA, S.B., "Irradiation disinfestation of dry dates and the possibility of using combination treatments", *Combination Processes in Food Irradiation (Proc. Int. Symp. Colombo, 1980)*, IAEA, Vienna (1981) 217.
- [11] GIDDINGS, G.G., "99.9968% mortality...", *Food Technol.* 37 2 (1983) 24.
- [12] VAS, K., "Technological feasibility of combination treatments", *Combination Processes in Food Irradiation (Proc. Int. Symp. Colombo, 1980)*, IAEA, Vienna (1981) 125.
- [13] AHMED, M.S.H., KADHUM, A.A., HAMEED, A.A., ALI, S.R., AL-HAKKAK, Z.S., Cytoplasmic analysis of *Ephesia castella* adult females collected in different regions of Iraq, *J. Stored Prod. Res.* 20 3 (1984) 151.
- [14] AHMED, M.S.H., et al., Disinfestation of commercially packed dates, Zahdi variety, by ionizing radiation, *Date Palm J.* 1 2 (1982) 249.
- [15] AUDA, H., NASSER, L.K., "Chemical studies on the influence of a combined process of heat and irradiation on carbohydrates, proteins and amino acids of dates", *Combination Processes in Food Irradiation (Proc. Int. Symp. Colombo, 1980)*, IAEA, Vienna (1981) 117.
- [16] CLINE, L.D., HIGHLAND, H.A., Minimum size of holes allowing passage of adults of stored-product Coleoptera, *J. Ga. Entomol. Soc.* 16 (1981) 525.

**EFFECTS OF GAMMA RADIATION ON TESTES
AND ON THE REPRODUCTIVE ABILITY
OF THE MEDITERRANEAN FLOUR MOTH,
Anagasta kühniella Zell. (LEPIDOPTERA:PHYCITIDAE)**

J. ROSADA
Radioisotope Laboratory,
Plant Protection Institute,
Poznań, Poland

Abstract

EFFECTS OF GAMMA RADIATION ON TESTES AND ON THE REPRODUCTIVE ABILITY OF THE MEDITERRANEAN FLOUR MOTH, *Anagasta kühniella* Zell. (LEPIDOPTERA: PHYCITIDAE).

Fifth stage male larvae, pupae 24 h before emergence of adults and one day old males of the Mediterranean flour moth, *Anagasta kühniella* Zell., were treated with gamma radiation. The doses ranged from 25 to 160 Gy (for larvae) and from 40 to 600 Gy (for pupae and adults). Histological observations of the testes and spermatogenic material were made and the reproductive ability of irradiated males paired with non-irradiated females was determined. In larval testes, spermatogonia were found to be the most sensitive to radiation, followed by spermatocytes. Damage to these stages increased in proportion to the dose applied and the time after irradiation. Spermatids and sperm showed relatively high resistance to gamma radiation. Also, no irradiation induced changes were observed in epithelial cells and in the septa between the follicles. Irradiation considerably prolonged the larval period and delayed pupation. The number of emerging adults decreased, while the percentage of deformed individuals increased. Males obtained from irradiated larvae were semi-sterile. Pupae and adult males were more resistant to gamma radiation than larvae. No delay in the emergence of adults from irradiated pupae was observed. Emerging males had no degenerative changes. The doses from 320 to 480 Gy were semi-sterilizing, both for pupae and adult males, while the 600 Gy dose induced 100% sterility.

1. INTRODUCTION

The control of stored products insects by ionizing radiation appears to be one of the possible applications of radiation for food preservation. Research has been undertaken on the possibility of applying irradiation to control many different pests, including the Mediterranean flour moth, *Anagasta kühniella* Zell. This insect appears almost everywhere in the world and causes much damage to stored grains and flour products. In Poland it is considered to be one of the most destructive grain and flour pests.

The losses caused by *A. kühniella* have two aspects: qualitative (product pollution) and quantitative (loss of the mass of stored products). Most of the damage is caused by larvae since adults do not take in food. The remains of dead 'individuals', however, may be the reason the product becomes polluted.

The Mediterranean flour moth, like other species of Lepidoptera, has been defined as being more resistant to radiation than most other insects [1-5]. The purpose of the study discussed in this paper was to investigate various effects of gamma radiation on the development and reproductive ability of *A. kühniella* at different stages of its development. To better understand these phenomena, histological and morphometric studies were made of the testes and spermatogenic tissues of fifth stage irradiated larvae.

2. MATERIALS AND METHODS

Test insects were reared at a temperature of $26 \pm 1^\circ\text{C}$ and $75 \pm 5\%$ relative humidity (RH) on a natural medium of ground wheat. Fifth stage male larvae (at the beginning phase of the last larval stage), pupae 24 h before emergence of adults and one day old males were treated in a cobalt-60 irradiator. The doses ranged from 25 to 160 Gy (for larvae) and from 40 to 600 Gy (for pupae and adults). The strength of the dose was 40 Gy/min.

The development of irradiated larvae and pupae was observed each day after exposure. The reproductive ability of irradiated males, paired with virgin, non-irradiated females, was determined. The number of moths in the successive F_1 , F_2 and F_3 generations was studied.

Histological and morphometric evaluations of irradiation changes in the structure of larval testes were also carried out. The analysis included larvae 24 h and 9 d after irradiation.

Larvae were fixed in Carnoy's fixative, washed several times in absolute ethanol and left there for four days. The dehydrated larvae were placed for 12 h in a mixture of absolute ethanol and benzene. Next, the tissues were cleaned in benzene, transferred into a mixture of benzene and paraffin and placed for 14 h in an oven at $37 \pm 1^\circ\text{C}$. They were then placed in low melting paraffin (56°C) for 24 h and in high melting paraffin (63°C) for 10 h. Finally, the insects were embedded in high melting paraffin blocks. Serial sections $5 \mu\text{m}$ thick were cut from each block with a microtome. After a routine procedure, they were stained with Harris's haematoxylin and eosin (HE). The dehydrated and cleaned preparations were mounted in Canada balsam.

Morphometric measurements were made by means of Weibel's method [6]. The relative volume of cell collections belonging to the basic stages of spermatogenesis, as well as the volumes of vacuolated areas and connective tissue, were determined. The results were tested by statistical analysis with the help of Duncan's and Fischer's tests.

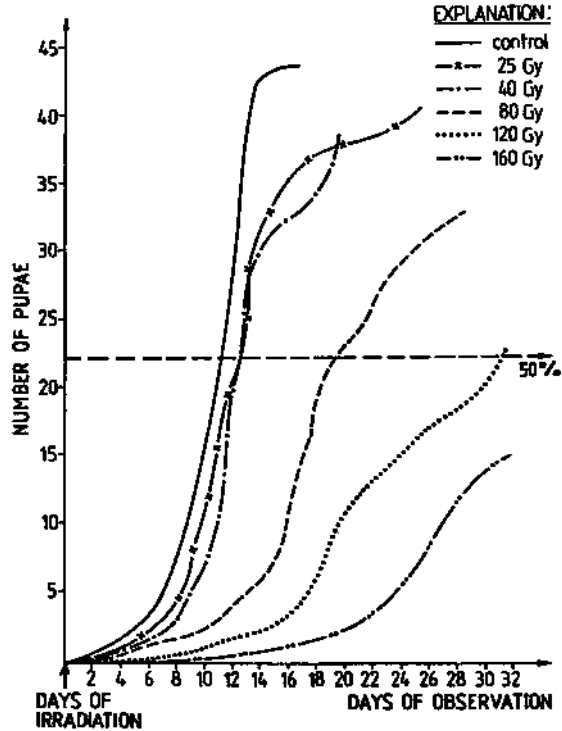

FIG. 1. Effects of gamma radiation on pupation of larvae and the number of pupae obtained of *A. külliella*. Number of irradiated larvae: $n = 45$.

3. RESULTS

3.1. Effects of radiation on the development of larvae

The exposure of fifth stage male larvae to various doses of gamma radiation affected the process of their development. Irradiation considerably prolonged the larval period and delayed pupation (Fig. 1). The greatest delay in pupation was observed after doses of 80, 120 and 160 Gy. These doses also reduced the percentage of pupae obtained.

In addition, the number of emerging adults decreased, while the percentage of deformed individuals increased in proportion to the dose applied. After the 120 Gy dose, 100% of the emerging males were deformed. Adults obtained from irradiated larvae were smaller than the normal ones, showed very weak mobility and their wings were poorly developed, were folded or even absent. After a dose of 160 Gy, no adult emergence was observed.

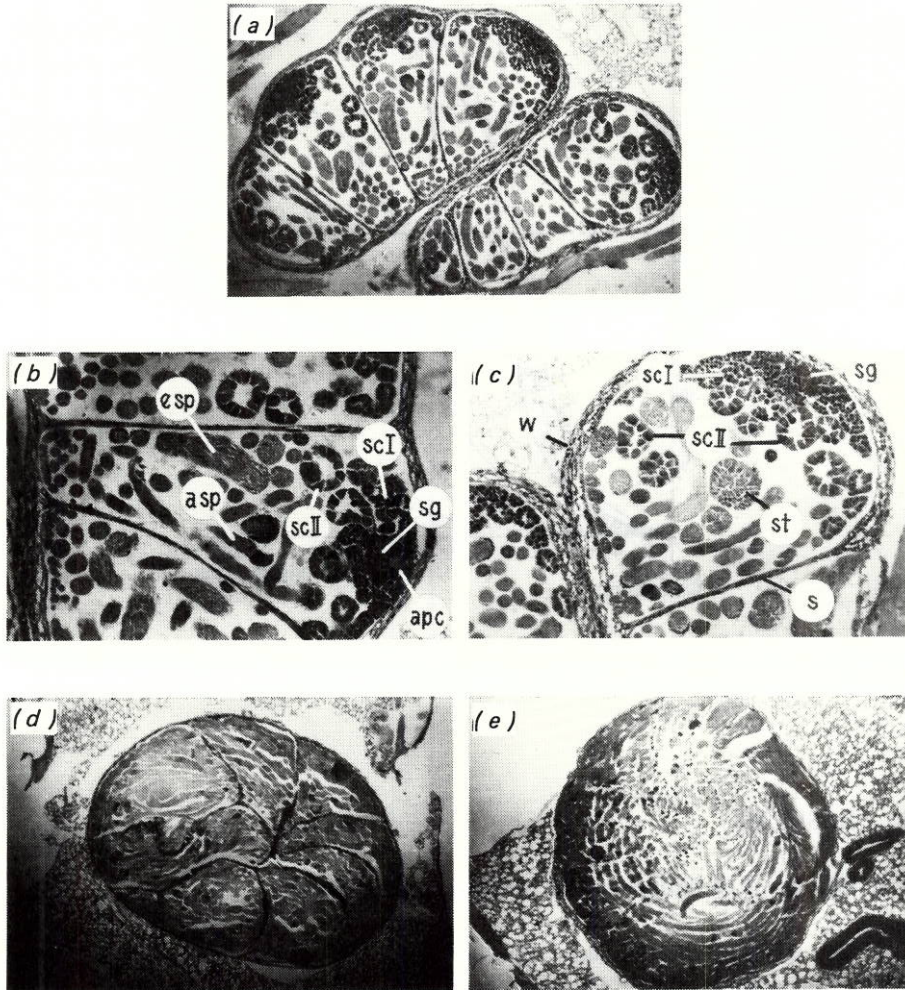

FIG. 2. Testes of fifth stage control larvae and maturing pupae of *A. kühniella*. (a) twin testes of larva. (b,c) single follicles showing details of spermatogenic material. apc: apical cell; sg: cysts of spermatogonia; scI, scII: cysts of primary and secondary spermatocytes; st: developing spermatids; esp: eupyrene sperm; asp: apyrene sperm; s: follicular septum; w: wall of testis. (d) Single spherical testis of young pupae. (e) Single testis of mature pupa.

3.2. Effects of radiation on the reproductive ability of adults emerging from irradiated larvae

The reproductive ability of males obtained from irradiated larvae was tested only on non-deformed individuals paired with virgin females. Gamma radiation (from 25 to 80 Gy) reduced, in proportion to the dose applied, the number of adults and increased the percentage of males in the F_1 generation.

The reduction of progeny in the F_1 generation suggested that gamma radiation induced semi-sterility in P_1 males. This semi-sterility was also carried over into the F_2 and F_3 generations. After exposure to 80 Gy, semi-sterile P_1 males produced the F_1 generation, which was completely sterile as no F_2 generation was obtained.

3.3. Effects of radiation on the structure of larval testes

3.3.1. Structure of normal testes

A fifth stage male larva of *A. kühniella* has a pair of testes composed of four sac-like follicles separated by septa (Fig. 2(a)). At this stage each follicle contains a large number of gonial cells in the successive stages of development (Figs 2(b) and 2(c)). At the top of each follicle there is an apical cell surrounded by spermatogonia. Next there are primary and secondary spermatocytes, spermatids and sperm. Spermatogonia and spermatocytes have large, well defined nuclei and these cells are grouped into cysts. Two types of sperm bundles were observed containing two morphologically distinct types of sperm: eupyrene — sinuous, with distinct nuclei at the anterior end, and apyrene — shorter, closely packed with less distinct nuclei located midway along their length.

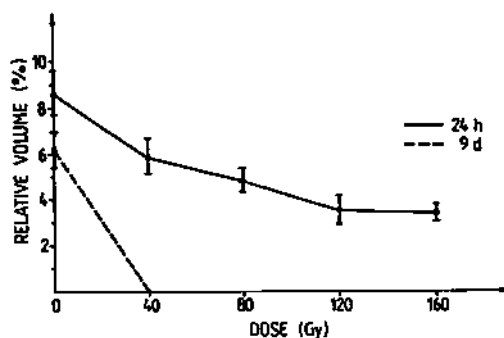

FIG. 3. Relative volume of spermatogonia in larval testes of *A. kühniella* 24 h and 9 d after irradiation. Results are expressed as a percentage of the total volume of the testes. Vertical lines denote standard errors (SE). Number of larvae in each group: $n = 5$.

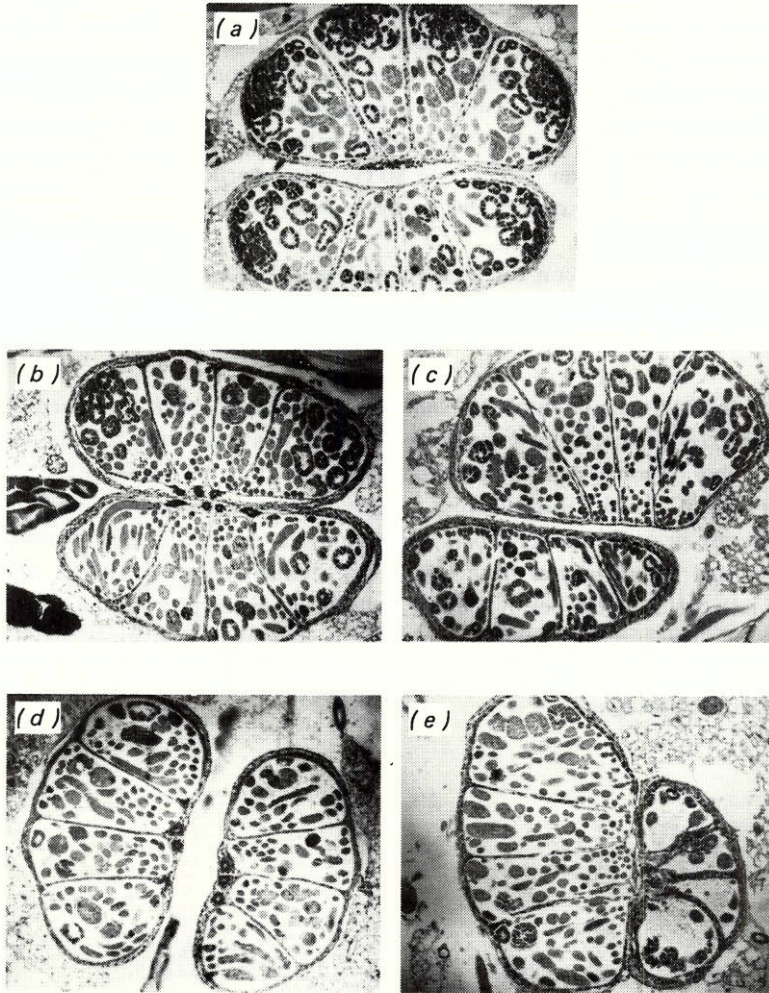

FIG. 4. Testes of fifth stage larvae on the ninth day after irradiation. (a) control; (b) 40 Gy; (c) 80 Gy; (d) 120 Gy; (e) 160 Gy.

The two testes of the larvae fuse in the pupal stage to form a single spherical mass, which in the beginning consists of eight follicles separated by septa (Fig. 2(d)). In the course of pupal maturation, the septa between the follicles gradually disappear. Most of the central area of the fused testes is filled with closely packed sperm bundles (Fig. 2(e)).

3.3.2. *Structure of larval testes after irradiation*

The exposure of fifth stage male larvae to gamma radiation affected the process of spermatogenesis. The collections of gonial cells were destroyed and depleted. This damage increased in proportion to the dose applied and the period of time after irradiation.

Spermatogonia were found to be the most sensitive to radiation. As early as 24 h after irradiation, destruction of spermatogonia in the population could be observed. The destroyed spermatogonia merged into a darkly coloured mass separated by vacuolated areas. Morphometric evaluation showed a rapid decrease in the relative volume of spermatogonia in all irradiated groups (Fig. 3). A dose of 160 Gy caused a more than twofold reduction in the relative volume of spermatogonia as compared with the control group. On the ninth day after irradiation, necrosis and complete disappearance of spermatogonia by liquefaction were observed (Figs 3, 4(b)–4(e) and 5(b)–5(e)).

Spermatocytes were found to be the second radiosensitive stage of spermatogenesis. In contrast to spermatogonia, however, no rapid reduction in the relative volume of spermatocytes was observed 24 h after irradiation (Fig. 6). After lower doses (40–80 Gy), spermatocytes retained their normal shape and did not differ in appearance from the analogous cells of the control individuals. After doses of 120 and 160 Gy, only changes in the appearance of the spermatocytes (especially the primary ones) were observed. The cells were more intense in colour and had enlarged nuclei. Nine days after irradiation, each of the doses applied caused a progressive reduction in the relative volume of spermatocytes. Most of them were degenerated. A dose of 160 Gy resulted in a fourfold reduction in the relative volume of spermatocytes as compared with the control (Fig. 6). However, none of the doses applied caused the total disappearance of all spermatocyte cells. Those which survived irradiation (especially at the highest doses) shrank to less than normal size and were more coloured. Their cysts were broken up and the cell nuclei were enlarged (Figs 4(b)–4(e) and 5(b)–5(e)).

Spermatids showed relatively high resistance to gamma radiation. Twenty-four hours after exposure, no changes in the relative volume and in the appearance of spermatids were observed. On the ninth day after irradiation, a slight reduction in the relative volume of spermatids was observed only after doses of 120 and 160 Gy (Fig. 7).

As a result of the depletion and liquefaction of spermatogonia and spermatocytes, the relative volume of vacuolated areas increased (Fig. 8).

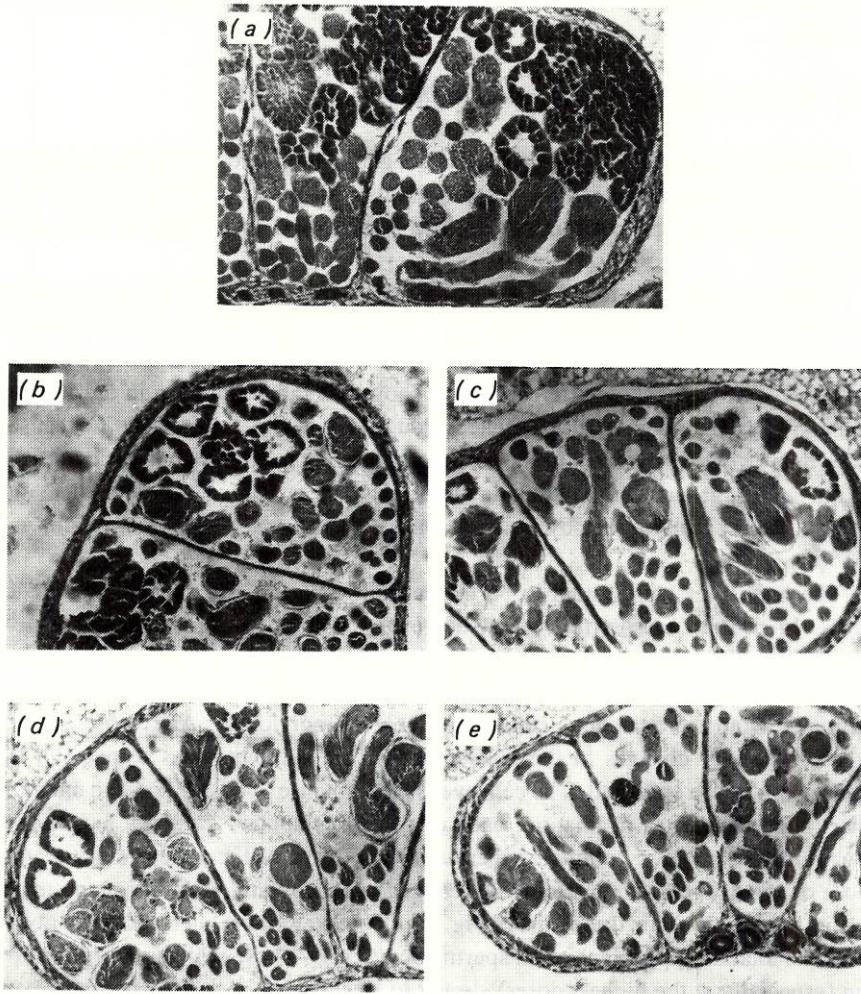

FIG. 5. Single follicles of fifth stage larval testes on the ninth day after irradiation showing details of gonial cell destruction. (a) control; (b) 40 Gy — total disappearance of spermatogonia and the beginning of the disintegration of spermatocytes; (c) 80 Gy, (d) 120 Gy — disintegration and disappearance of spermatocytes, loosening of sperm bundles; (e) 160 Gy — total disappearance of spermatocytes and bursting of single sperm bundles.

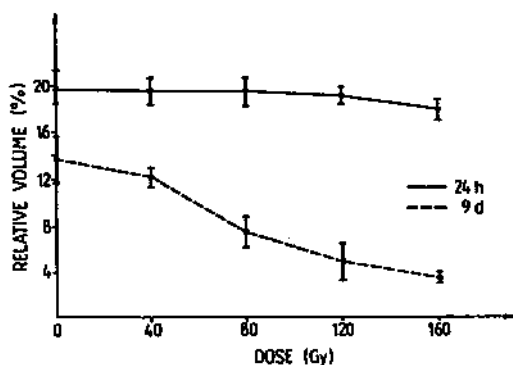

FIG. 6. Relative volume of spermatocytes in the larval testes of *A. kühniella* 24 h and 9 d after irradiation. Results are expressed as a percentage of the total volume of the testes. Vertical lines denote SE. Number of larvae in each group: $n = 5$.

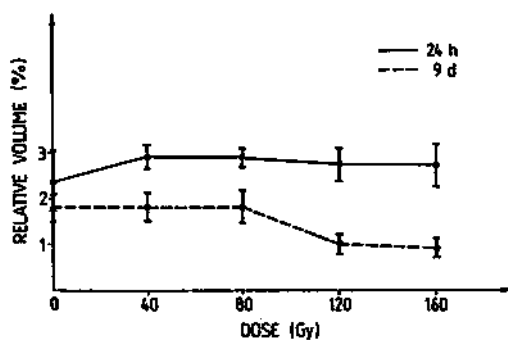

FIG. 7. Relative volume of spermatids in larval testes of *A. kühniella* 24 h and 9 d after irradiation. Results are expressed as a percentage of the total volume of the testes. Vertical lines denote SE. Number of larvae in each group: $n = 5$.

Sperm showed the highest resistance to gamma radiation. None of the doses applied, either after 24 h or 9 d, caused a reduction in their relative volume. Also, no irradiation induced changes were observed in the epithelial cells and in the septa between the follicles.

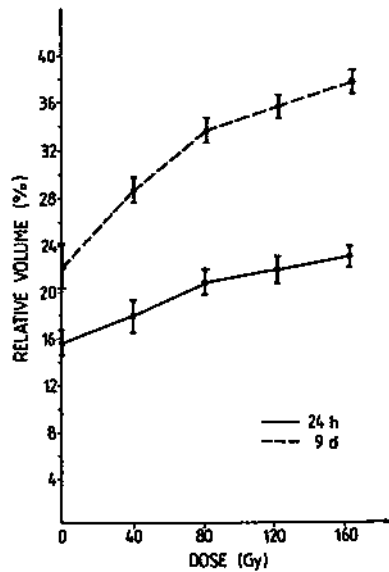

FIG. 8. Relative volume of vacuolated areas in larval testes of *A. kühniella* 24 h and 9 d after irradiation. Results are expressed as a percentage of the total volume of the testes. Vertical lines denote SE. Number of larvae in each group: $n = 5$.

3.4. Reproductive ability of *A. kühniella* males irradiated at the pupal stage and as one day old adults

Mature male pupae of *A. kühniella* were much more resistant to gamma radiation than their larvae. None of the doses applied from 40 to 600 Gy were able to completely prevent or delay the emergence of adults. The reproductive ability of males was tested by pairing them with non-irradiated, virgin females.

After doses of 40 to 240 Gy, the number of progeny in the F_1 generation was not found to be clearly related to the dose level. A visible reduction in the F_1 progeny was observed only after higher doses (320–480 Gy). These doses also increased the percentage of males in the F_1 generation. A dose of 480 Gy reduced the number of F_1 adults by about 75% as compared with the control. It was also determined that semi-sterile P_1 adults, emerging after doses of 320–480 Gy, produced completely sterile F_1 progeny as no F_2 generation was obtained. A dose of 600 Gy proved to be completely sterilizing for the P_1 males. Very similar results were obtained for the number of progeny after irradiation of one day old adult males. The dose range was the same as for pupae.

4. DISCUSSION

Gamma radiation affected the process of larvae development. Doses higher than 80 Gy considerably delayed pupation and reduced the number of pupae and adults. The percentage of deformed males increased in proportion to the dose applied. After a dose of 160 Gy, not a single adult male emerged. This corresponds with the results obtained by Van den Brande and Van de Woestijne, who showed that exposure of *A. kühniella* larvae to a dose of 90 Gy reduced the number of pupae [2]. A dose of 180 Gy resulted in the total absence of pupae. Erdman determined that the lethal dose for Mediterranean flour moth larvae amounted to 500 Gy [5]. However, he found that increased lethality of the larvae could already be observed after 150 Gy.

The study presented here has proved that radiation caused gross damage to the testes of the treated larvae and many of the gonial cells were killed. Spermatogonia were the most sensitive to radiation, followed by spermatocytes. Damage to these stages increased in proportion to the dose applied and to the time after irradiation. Spermatids and sperm showed a relatively high level of resistance to gamma radiation. Also, no changes induced by irradiation were observed in epithelial cells and in the septa between follicles.

Many different authors quoted by North [7] made similar observations after irradiation of other Lepidoptera species. Ashrafi et al. [8] showed that the majority of gonial cells were completely destroyed 24 h after exposure of Indian meal moth larvae, *Plodia interpunctella* Hübner, to 100 and 125 Gy. In this study, only on the ninth day after irradiation were the total disappearance of spermatogonia after 40 Gy of irradiation and a fourfold reduction in spermatocytes after 160 Gy of irradiation observed.

Pupae and adult males of *A. kühniella* were found to be more resistant to gamma radiation than larvae. None of the doses applied delayed the emergence of adults. Emerging males had no degenerative changes. Doses from 320 to 480 Gy were semi-sterilizing, both for pupae and for adult males. A dose of 600 Gy sterilized P₁ males completely. This is in agreement with the results obtained by Van den Brande and Pelereants [1] and Van den Brande and Van de Woestijne [2].

REFERENCES

- [1] VAN DEN BRANDE, J., PELERENTS, C., Quelques effets des rayons gamma sur la teigne de la farine et sur divers nématodes, C.R. Rech. Brux. 1 28 (1962) 11-47.
- [2] VAN DEN BRANDE, J., VAN DE WOESTIJNE, N., "Effect of gamma radiation on the Mediterranean flour moth, *Anagasta kühniella* Z. in different stages of development" Proc. 11th Int. Congr. on Entomology, Vienna, 1960, Vol. 2, C. Reisser, Vienna (1962) 563-567.
- [3] INTERNATIONAL ATOMIC ENERGY AGENCY, Insect Population Control by the Sterile-Male Technique (Proc. Panel Vienna, 1962) (LINDQUIST, A.W., Ed.), Technical Reports Series No. 21, IAEA, Vienna (1963).

- [4] BULL, J.O., WOND, I., Control of the Mediterranean flour moth, *Anagasta kuhniella* Zell., by sterile male release. II. Susceptibility to gamma radiation, Rep. AERE-R-2967, UKAEA Atomic Energy Research Establishment, Harwell (1963).
- [5] ERDMAN, H.E., Arrested development in X-rayed larvae of *Ephestia kuhniella* Zeller (Lepidoptera:Phycitidae), Am. Midl. Nat. **69** 1 (1963) 34-37.
- [6] WEIBEL, E.R., Stereological principles for morphometry in electron microscopic cytology, Int. Rev. Cytol. **26** (1969) 235-302.
- [7] NORTH, D.T., Inherited sterility in Lepidoptera, Annu. Rev. Entomol. **20** (1975) 167-182.
- [8] ASHRAFI, S.H., BROWER, J.H., TILTON, E.W., Gamma radiation effects on testes and on mating success of the Indian meal moth, *Plodia interpunctella*, Ann. Entomol. Soc. Am. **65** 5 (1972) 114-1149.

Poster Presentation

IAEA-SM-301/10P

POTENTIAL OF RADIATION AS A QUARANTINE TREATMENT FOR THE MOULD MITE, *Tyrophagus putrescentiae* (Schrank), IN AGRICULTURAL PRODUCTS*

S. IGNATOWICZ

Department of Applied Entomology,
Agricultural University of Warsaw,
Warsaw, Poland

Eggs, larvae, nymphs and adults of the mould mite, *Tyrophagus putrescentiae* (Schrank) (Acarina:Acaridae), a common pest in agriculture, were irradiated with gamma radiation using a cobalt-60 source. After irradiation, the fecundity, fertility and mortality of the adults which emerged were observed.

When the eggs were treated at a dose of 0.3 kGy, some larvae emerged, but soon died. With lower doses, sterile adults were occasionally obtained. The sensitivity of eggs to radiation seems to depend upon their age. Eggs irradiated from 0-1 d were the most susceptible, with the greatest mortality. No adults developed from larvae irradiated at 0.35 kGy or higher doses, but some sterile adults did develop from treated protonymphs. These males and females lived for a much shorter time than did the control.

Treated deutonymphs reached the adult stage even at 1.32 kGy, but they moulted with difficulty and the adults that emerged appeared to be weak and sluggish. The survival time of these mites was shorter at all dosage levels. Adults from the irradiated deutonymphs were infecund or they produced sterile eggs.

The results obtained show that radiosensitivity of mould mites decreases during their development. The following observations indicate that the adult stage of the mould mite is most resistant to gamma radiation.

At lower doses, 0.18-0.44 kGy of gamma radiation, males and females lived as long as, or longer than, the controls. Irradiation of mites at 0.88, 1.06, 1.32, 1.58 and 1.85 kGy caused 100% mortality of adults after 30, 26, 21, 10 and 8 d, respectively. Mites given a dose of 2.22 kGy died after three days.

* Research carried out with the support of the IAEA under Research Contract No. 4659/RB.

TABLE I. FECUNDITY AND FERTILITY OF 24-48 h OLD ADULT MOULD MITES IRRADIATED AT GAMMA RAY DOSES OF 0.9-2.11 kGy

Dose (kGy)	No. of mite pairs	Infecund pairs (%)	Fecundity (No. of eggs/♀)		Viability of eggs (%)
			Mean ± SD	Range	
2.11	42	100.0	—	—	—
1.85	54	100.0	—	—	—
1.58	56	98.2	2.0 ± 0.0	2	0.0
1.32	71	33.8	1.7 ± 1.1	1-5	0.0
1.06	57	31.6	4.2 ± 3.8	1-10	0.0
0.88	52	61.5	3.9 ± 2.3	1-9	0.0
0.79	50	16.0	4.1 ± 2.0	1-8	0.0
0.70	78	20.5	4.9 ± 2.6	1-14	0.0
0.62	66	21.2	4.4 ± 2.6	1-10	0.0
0.53	69	10.1	9.5 ± 13.7	1-19	0.0
0.44	46	34.8	4.3 ± 3.1	1-12	0.0
0.35	53	35.8	8.9 ± 16.7	1-21	0.0
0.26	40	10.0	15.4 ± 9.6	1-38	0.0
0.09	44	2.3	189.9 ± 80.7	33-320	73.8
0.00	21	0.0	415.0 ± 110.0	171-673	96.0

The use of such high doses of ionizing radiation in order to kill mites directly may adversely affect produce, which would require more shielding and thus incur greater expense. Thus, the criteria for efficacy of irradiation as a quarantine treatment of agricultural produce infested with acarid mites should be based on the inability of the mites to perpetuate at a new location, rather than on causing immediate mortality. This translates as a dose which prevents normal development and promotes sterilization of adults.

Sterility in the mould mite is achieved following irradiation of adult males and females at much lower doses than is needed to kill the adult mites. When both sexes were treated at 0.26 kGy or higher, mite pairs produced several eggs which were all sterile. At a dose of 0.18 kGy, fecundity of the mould mite was greatly reduced. The viability of eggs produced by mites treated at 0.18 kGy of gamma radiation was variable in the subsequent 'egg waves'. All eggs laid during the first ten days after irradiation died. Later on, the viability of eggs increased gradually to about 63% (control: 96%), giving normal offspring (Table I).

Therefore, irradiation of produce infested by mites at 0.26 kGy could be the treatment required to produce an acceptable level of quarantine security. At this dosage, adult survivors of the mould mite will be present in treated produce, but they will not give rise to offspring and thus this pest would not be able to perpetuate in a new area. However, the live mites present in the agricultural produce will be of concern to quarantine personnel. Thus, a simple test is needed to ensure that the mites have been irradiated and that they will not pose a quarantine risk.

It was found that the mites irradiated at 0.26, 0.53, 0.79 and 1.06 kGy produced eggs during the first days after treatment, being infecund thereafter. Adults which emerged from irradiated larvae or nymphs were infecund. Therefore, the test to verify that the mould mites have been irradiated and are incapable of reproduction, based on their infecundity, could be as follows:

- Isolate live females from a product,
- Place them into rearing cages containing wheat germ as food (e.g. five females per cage),
- Keep the cultures at 25°C and 85% relative humidity for three days,
- Record the number of eggs laid by these females.

When no eggs, or only a few eggs, are laid by females isolated from a product, it means that this product has been irradiated. When females produce more than 20 eggs per female during the three day period, one may conclude that the product has *not* been treated and the mites pose a quarantine risk.

SUBLETHAL EFFECTS OF RADIATION

(Session 7)

Chairman

C.P. SCHWALBE

United States of America

MATING COMPETITIVENESS OF RADIATION STERILIZED GREENHOUSE WHITEFLIES

N. GENCHEV
Plant Protection Institute,
Kostinbrod, Bulgaria

Abstract

MATING COMPETITIVENESS OF RADIATION STERILIZED GREENHOUSE WHITEFLIES.

Discussed in the paper are the results of studies on the competitiveness of radiation sterilized whiteflies, which represent part of a complex research programme on the potential of the sterile insect technique for genetic control of this insect under greenhouse conditions. Data obtained in laboratory experiments are compared with the effects predicted by using a combinatorial statistical model which describes the interactions between sterile and fertile insects, depending on their ratio in the population, their reproduction physiology and the type of induced sterility. Results of small scale greenhouse trials are also presented.

1. INTRODUCTION

The greenhouse whitefly (*Trialeurodes vaporariorum* Westw.) (Homoptera: Aleyrodidae) is a serious pest of many vegetable and flower plants grown in the greenhouses of Bulgaria. Its conventional control is achieved mainly by intensive insecticide treatments, which are inevitably accompanied by such well known negative consequences as intensification of the pesticide residue problem, development of resistance to the insecticides applied, etc. All of these drawbacks of the purely chemical method necessitated the search for alternatives, mainly from among certain biological agents used alone or in integrated programmes. The use of the sterile insect technique (SIT) to suppress whitefly populations is also a possible solution to the problems mentioned above.

Discussed in this paper are the results of studies on the competitiveness of radiation sterilized whiteflies, which represent part of a complex research programme on the potential of SIT for genetic control of the insect under greenhouse conditions. The experimental work was based on the following preliminary information [1-3].

The reproduction of *T. vaporariorum* is a complex involving obligatory gametogamy, resulting in female generation from the fertilized oocytes and parthenogenesis in the form of arrhenotoky (male offspring from unfertilized eggs). Male and female whiteflies are in a position to mate more than once, but the actual number of their copulations is not yet known.

Gamma radiation induced sterility of males irradiated as puparia or imagoes is a result of provoked dominant lethal mutations in spermatozoa accompanied by partial sperm inactivation, the absolute sterilizing doses being 6 and 7 krad¹, respectively. The radiation sterilization of females treated at the same ontogenetic stages is due to dominant lethals in oocytes and partial infecundity (fully sterilizing doses of 5 and 6 krad).

Mating between sterilized male and fertile female parents caused forced arrhenotoky, leading to a lack of female 'individuals' in the first filial generation (F₁). The sterilized female parents gave no progeny. It was found that the radiation doses applied did not affect the longevity of the irradiated whiteflies.

2. MATERIALS AND METHODS

All laboratory investigations were carried out on individuals collected as puparia from colonies developed on greenhouse cucumber plants. The experimental imaginal populations were maintained on bean plants planted in pots and placed in appropriate glass cages covered with gauze. The room conditions were: temperature of 22–23°C and relative humidity of about 60%, with no additional light or changes in the photoperiod. Sterilization was carried out by gamma ray irradiation (⁶⁰Co) of puparia or imagoes, with corresponding doses delivered at 12 ± 5% rad/s.

The ratios used to test for the competitiveness of sterilized whiteflies were as follows: (1) sterile males:fertile males:fertile females (S♂:F♂:F♀) and sterile females:fertile females:fertile males (S♀:F♀:F♂), in the ranges 1–50:1:1 and 1–30:1:1, respectively; (2) sterile males + sterile females:fertile males + fertile females (S♂+S♀:F♂+F♀), in the range 1+1 to 30+30:1+1; (3) 0:1:1 and 0+0:1+1 (control). All of the ratios used were composed on the basis of a unit group of ten individuals, e.g. 10:1:1 = 100:10:10.

Trials on native whitefly populations were carried out in cages (area 9 m²) situated along one greenhouse shed and isolated by calico walls and hangings. Intermediate cages treated with insecticides improved the isolation between the populations into which sterilized whiteflies were introduced. Two rows of six plants of cucumbers were planted in the cages at standard intervals.

The pre-release estimate of the number of puparia on leaves with their colonies was made by means of a special pattern with experimentally established parameters. Sex ratio changes were determined by laboratory assay of leaves sampled for every variant using the following scheme: one leaf with puparia per plant for P₁, half of the total number of leaves with puparium populations for F₁ and all leaves with puparia for the F₂ generations.

¹ 1 rad = 1.00 × 10⁻² Gy.

Strings of leaves with irradiated puparium colonies were placed just beneath the plant storey with P_1 native puparium populations. The release ratios were: (a) $S\sigma + S\varphi : F\sigma + F\varphi$, 10(20,30)+10(20,30):1+1; and (b) the untreated control. A postulate for the identity of sex ratios of the sterilized and native populations had to be accepted out of necessity. Sterile individuals were released in native populations of 1000–1400 puparia per cage.

3. RESULTS AND DISCUSSION

Data obtained in the laboratory experiments are compared with the effect predicted by using a combinatorial statistical model [4], which describes the interactions between sterile and fertile insects depending on their ratio in the population, their reproduction physiology and the type of induced sterility. Regardless of whether the ratio includes or does not include sterilized females, the expected process can be characterized by (1) a relatively rapid increase in the number of males in the F_1 generation for the parental ratios of $S\sigma : F\sigma$ up to 10:1; and (2) a slower increase in the number of males in the F_1 generation for P_1 ratios $> 10:1$.

The similarity of the competitiveness test results for male whiteflies sterilized as puparia or imagoes (Tables I and II) allows a general interpretation. As can be seen, the results follow a tendency that adequately fits the theoretical results described by the model, i.e. a rapid increase in the number of F_1 males up to a ratio of 10:1 and their slower rate of increase in the higher ratio range. However, a good approximation to the predicted values exists only at the highest ratios of 30:1 and 50:1. The lack of any significant difference between the data obtained in the two experiments demonstrates the equivalent physiological state of the sterilized male individuals despite their irradiation at different stages of development.

The induced sperm inactivation in males and the polygamy of female *T. vaporariorum* diminish the role of irradiated spermatozoa in the total sex competition. In this case, the effect is probably due mainly to mating competitiveness in the proper sense of the term. Such a concept plausibly explains the necessity for such high ratios of sterile:fertile whiteflies for achieving a greater effect.

For insects with normal types of reproduction (gametogamy only), there are well formulated opinions regarding the role of sterilized females released simultaneously with sterile male individuals and the factors controlling the total effect [5–7]. However, of special interest to us is the viewpoint of Eftimov et al., who stated that if arrhenotoky was involved in propagation of a species, and the sterilizing effect was sperm inactivation, SIT could be more effective than the sterile male technique, since the sterile females would compete with the native females for the fertile male partners [4]. Taking this assumption into consideration, we explored the role of sterilized females. The corresponding results can be interpreted as follows.

In fact, the numerical superiority of sterilized female whiteflies leads to some changes in F_1 generation sex ratios in favour of the males (Table III). The effect has

TABLE I. COMPETITIVENESS OF MALE WHITEFLIES STERILIZED AS PUPARIA

P ₁ ratio (Sσ:Fσ:F♀)	F ₁ males in the population (%)	
	Predicted	Experimental
0:1:1	50.0±5.0	51.6±3.1
1:1:1	75.0±7.9	69.4±3.2
5:1:1	91.7±9.4	81.5±1.4
10:1:1	95.4±9.7	87.2±2.1
15:1:1	96.9±9.9	90.6±1.8
20:1:1	97.6±9.9	91.9±2.2
25:1:1	98.1±9.9	93.3±1.7
30:1:1	98.4±9.9	96.4±1.6
50:1:1	99.0±9.9	97.1±1.8

TABLE II. COMPETITIVENESS OF MALE WHITEFLIES STERILIZED AS IMAGOS

P ₁ ratio (Sσ:Fσ:F♀)	F ₁ males in the population (%)	
	Predicted	Experimental
0:1:1	50.0±5.0	42.3±2.3
1:1:1	75.0±7.9	70.2±1.2
5:1:1	91.7±9.4	82.4±1.8
10:1:1	95.4±9.7	88.1±2.3
15:1:1	96.9±9.9	91.3±1.4
20:1:1	97.6±9.9	93.2±1.5
25:1:1	98.1±9.9	94.3±1.6
30:1:1	98.4±9.9	95.2±1.5
50:1:1	99.0±9.9	96.6±1.8

statistical significance for the ratio $S\varnothing:F\varnothing \geq 15:1$. However, against all expectations, the total competitiveness of male and female sterile individuals did not differ essentially from that obtained in the experiments with the 'pure' ratio of $S\sigma:F\sigma:F\varnothing$ (compare Table IV with Tables I and II). In fact, it is likely that what we observed was nothing but a result of interference on the part of sterilized males which had engaged a greater number of sterile female partners.

TABLE III. COMPETITIVENESS OF FEMALE WHITEFLIES STERILIZED AS PUPARIA

P ₁ ratio (S \varnothing :F \varnothing :F σ)	F ₁ males in the population (%)
0:1:1	50.8±1.9
1:1:1	49.7±3.8
5:1:1	60.2±5.0
10:1:1	61.5±4.4
15:1:1	65.5±3.0
20:1:1	64.4±3.5
25:1:1	67.5±3.0
30:1:1	70.0±3.8

TABLE IV. TOTAL COMPETITIVENESS OF MALE AND FEMALE WHITEFLIES STERILIZED AS PUPARIA

P ₁ ratio (S σ +S \varnothing :F σ +F \varnothing)	F ₁ males in the population (%)	
	Predicted	Experimental
0+0:1+1	50.0±5.0	49.0±2.5
1+1:1+1	75.0±7.9	71.1±1.7
5+5:1+1	91.7±9.4	84.2±2.7
10+10:1+1	95.4±9.7	87.3±1.5
15+15:1+1	96.9±9.9	89.7±2.0
20+20:1+1	97.6±9.9	89.3±2.6
25+25:1+1	98.1±9.9	94.0±1.5
30+30:1+1	98.4±9.9	97.1±1.9

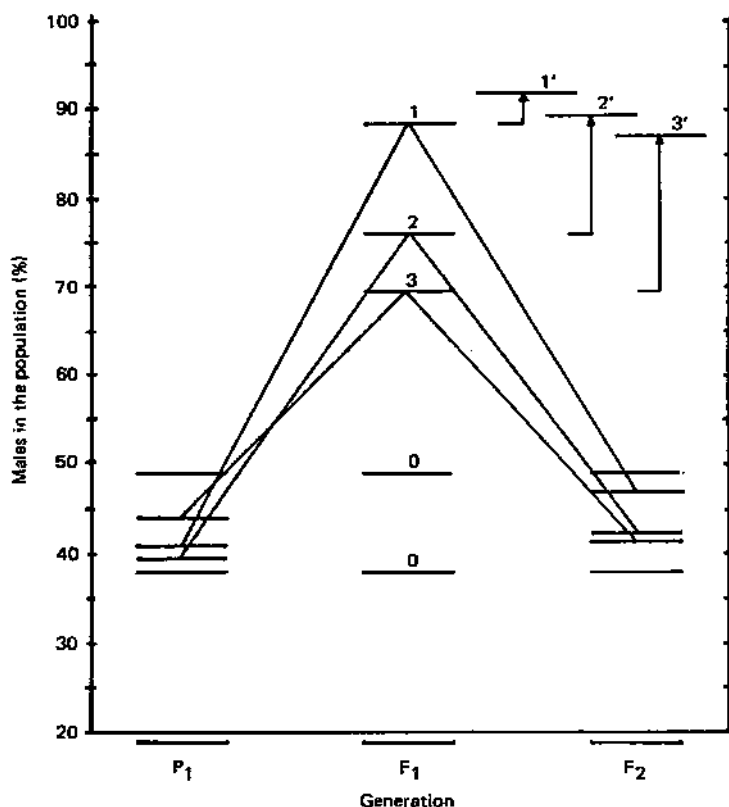

FIG. 1. Percentage of males in F_1 and F_2 populations after introduction of sterilized whiteflies in P_1 native populations. 1, 2, 3 — levels for $S\sigma + S\varphi : F\sigma + F\varphi = 10(20,30) + 10(20,30) : 1 + 1$, respectively. 1', 2', 3' — the same levels achieved in corresponding laboratory experiments. 0 — control limit.

The results of the greenhouse cage trials are plotted in Fig. 1. Obviously, as a tendency, they correspond with the data from the laboratory experiments, i.e. the number of males in the F_1 generation of the treated whitefly populations increased markedly in relation to the level of the $S\sigma + S\varphi : F\sigma + F\varphi$ ratio. On the other hand, except for the highest ratio, $30 + 30 : 1 + 1$ (better data approximation), the effect of the $20(10) + 20(10) : 1 + 1$ ratio was much lower than that obtained from the laboratory.

There are probably many factors responsible for this result. However, the following biological circumstances can be considered to be of great importance. Communication between adult whiteflies is usually achieved at very short distances, depending on the population density. The final effect of SIT, which here is based chiefly on mating competition, will therefore be a function both of the optimal number of released sterile insects and their uniform distribution in the treated population.

Accordingly, these factors depend on the target population size, the accuracy of the technique for measuring it and the coincidence between the flight of sterilized and wild whiteflies. In our case we suppose that the relatively weaker effect was due to circumstances connected with the first two conditions, i.e. release of sterile individuals into numerous unsuitable target populations and quantitative methods which are not sufficiently accurate to carry out pre-release appraisal of the native and sterilized puparium colonies. Nevertheless, the expected process was actually registered and well demonstrated.

What conclusions could be drawn from the facts presented and discussed above? First, it should be noted again that sex competition between sterilized and fertile male whiteflies was realized mainly with respect to matings and resulted in an increase in the number of males in the first filial generation. Causing a deficiency or lack of females in the F_1 generation, this forced arrhenotoky will lead indirectly to a reduction in the F_2 population. Consequently, by applying SIT, it is quite possible to convert parthenogenesis from being a necessity for the normal reproduction process of this insect process to being a lethal factor for the population.

REFERENCES

- [1] GENCHEV, N., Radiation sterilization of the greenhouse whitefly (*Trialeurodes vaporariorum* Westw., Homoptera:Aleyrodidae). I. Lethal radiation effects on puparia and imagoes, Soil Sci. Agrochem. Plant. Prot. XXI 5 (1986) 125-133 (in Bulgarian).
- [2] GENCHEV, N., Radiation sterilization of the greenhouse whitefly (*Trialeurodes vaporariorum* Westw., Homoptera:Aleyrodidae). II. Sterilizing effects of radiation on puparia and imagoes, Soil Sci. Agrochem. Plant Prot. XXII 1 (1987) 108-115 (in Bulgarian).
- [3] GENCHEV, N., unpublished.
- [4] EFTIMOV, I., GENCHEV, N., IVANCHEV, D., A combinatorial model for evaluating the changes in population number produced by radiation sterilization applied in the control of harmful insects, Hort. Vitic. Sci. XVIII 3 (1981) 24-32 (in Bulgarian).
- [5] AILAM, G., GALUN, R., Optimal sex ratio for the control of insects by the sterility method, Ann. Entomol. Soc. Am. 60 (1976) 41-43.
- [6] DAVIDSON, G., Genetic Control of Insect Pests, Academic Press, New York and London (1974).
- [7] WHITTEN, M.J., TAYLOR, W.C., A role for sterile females in insect control, J. Econ. Entomol. 63 1 (1970) 269-272.

**EFFECTS OF IRRADIATION AND EXPOSURE
TO NITROGEN ON THE
FREE AMINO ACID CONTENT
OF *Tribolium confusum* J. du VAL.
(COLEOPTERA: TENEBRIONIDAE)**

L.A. BUSCARLET, J.L. RAVENEL
Centre d'études nucléaires de Cadarache,
Commissariat à l'énergie atomique,
Saint-Paul-lez-Durance, France

S.R. KASSIS
Plant Protection Institute,
Agricultural Research Center,
Dokki, Cairo,
Egypt

Abstract

EFFECTS OF IRRADIATION AND EXPOSURE TO NITROGEN ON THE FREE AMINO ACID CONTENT OF *Tribolium confusum* J. du VAL. (COLEOPTERA: TENEBRIONIDAE).

The effects of irradiation, at doses which are not lethal or are partially lethal (< 60 Gy) were compared with the effect of anoxia on the change in free amino acid (FAA) concentrations in *Tribolium confusum* adults. At 20 Gy, irradiation generally had little effect on FAA content except in the cases of glutamine (GLN) and glutamic acid (GLU). The changes at 40 Gy were similar to those observed at 20 Gy, and after 13 d the initial pool was quite restored. At 60 Gy, the contents of all of the FAAs declined with time, except for lysine content, which increased up to 140% relative to the control after 13 d. Short exposures to nitrogen (0.5–6 h) caused changes only in GLU and GLN contents, which decreased, and in alanine (ALA) content, which increased up to 154%. After 3 h of exposure, the time needed to restore the levels of these contents was between 24 h (for GLU and ALA) and 72 h (for GLN). Longer exposures (9–15 h) caused an increase in the contents of all of the FAAs, except for GLN and proline. Some assumptions based on the biochemical mechanisms of synthesis and degradation of the FAAs were used to explain the effects of irradiation and exposure to nitrogen, both treatments being applied either at a non-lethal or lethal level. From a practical point of view, the FAA distribution pattern in insects sampled in stores may be a means of identification of the kind of disinfestation treatment (irradiation or controlled atmosphere) previously applied to the product.

1. INTRODUCTION

The effect of irradiation on the mortality of *Tribolium confusum* adults varies with the dose. At up to 40 Gy, no mortality is observed over several weeks. At 60 Gy, 100% of the population survives after 9 d and 10% after 28 d. Between 120 and 1000 Gy, the population survives for 8 d and dies in totality after 14–16 d [1].

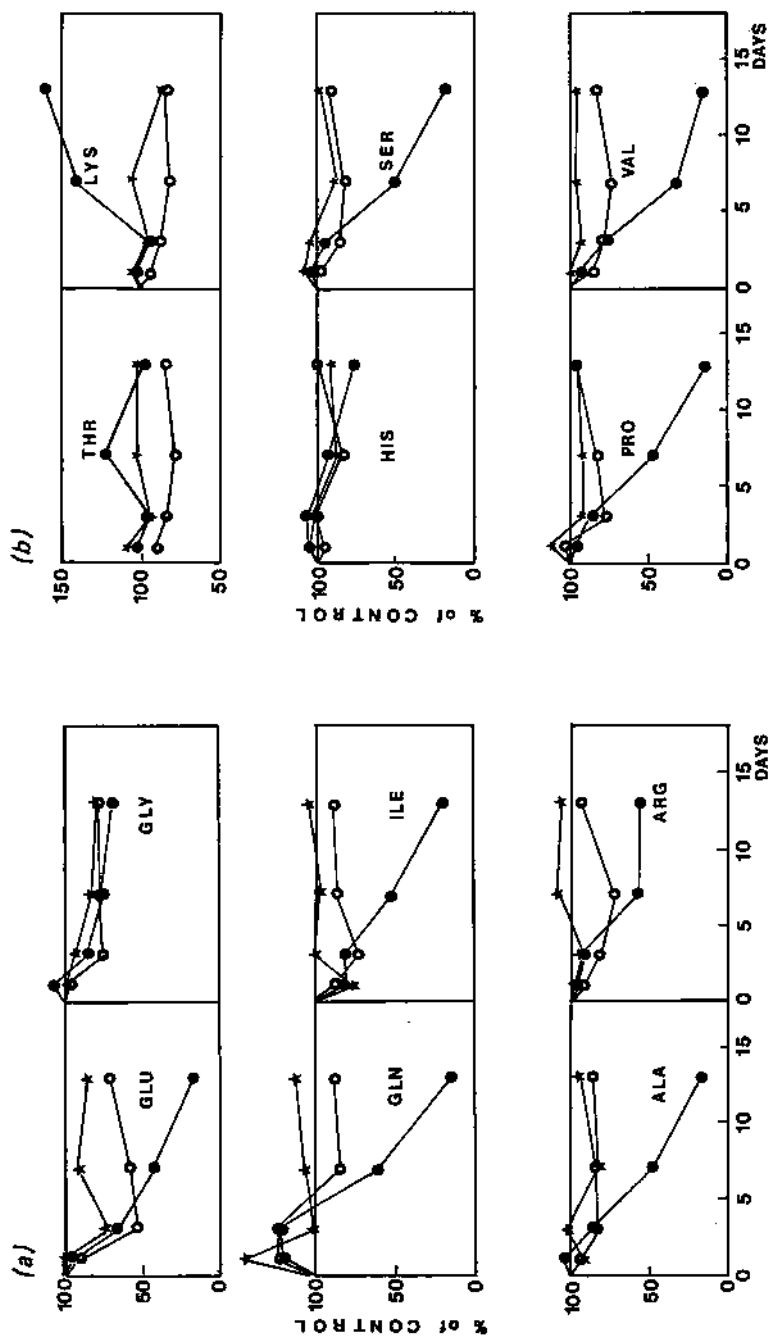

FIG. 1. (a, b) Changes in FAA contents of *T. confusum* adult males after irradiation at 20 (*), 40 (●) and 60 (◐) Gy.

The effect of exposure to nitrogen on the mortality of *T. confusum* adults is different. Mortality is observed immediately after the end of the treatment and increases in a few days up to a maximum value which is directly related to the exposure time. One hundred per cent mortality is attained when there is exposure for 17 h.

Buscarlet et al. [2] have shown that the free amino acid (FAA) contents of *T. confusum* adult males are changed after irradiation. In insects irradiated at 63–504 Gy, the concentrations of the 13 most abundant FAAs change with time in the same way as in starved insects. This is explained by the damage caused to the digestive functions by the ionizing radiation. In this range of doses, the changes in concentrations with time are not influenced by the level of the dose, which is also observed for the mortality rate.

The aim of this study was to determine in *T. confusum* adults the effects of irradiation, at non-lethal doses or at partially lethal doses (<60 Gy), on changes in FAA concentrations and the ability of insects to restore the amino acid pool. The effect of anoxia on the change in FAA concentrations was the basis of a comparative study of insects exposed to nitrogen at various times.

2. MATERIALS AND METHODS

Experiments were carried out with one week old *T. confusum* adults reared in darkness at $28 \pm 1^\circ\text{C}$ and $65 \pm 5\%$ relative humidity on whole wheat flour and yeast (in a ratio of 19:1). The different treatments were assigned to groups of 80 insects. Irradiation at 20, 40 and 60 Gy was carried out in a cobalt-60 irradiator delivering 4.5 Gy/min. For the anoxic treatment, Petri dishes were inserted into chambers that were flushed with nitrogen and closed by electropneumatic valves when the oxygen content was less than 0.1%, as assessed by an oxygen analyser connected to the chamber.

The methods used for sampling and sexing the insects and extracting and determining the FAA contents were described previously [1].

3. RESULTS

3.1. Effect of irradiation

The effect of irradiation at 20, 40 and 60 Gy is shown in Figs 1(a) and 1(b). The content of each FAA determined at 0, 1, 3, 7 and 13 d after treatment is referred to the corresponding control value determined on the same day. From the changes in the FAA contents measured in the controls over 18 d, the maximum variation coefficient observed was 20%. Hence those differences between the treated and control insects less than 20% were not considered as being significant.

TABLE I. EFFECT OF SHORT EXPOSURE TIMES TO NITROGEN ON THE FAA CONTENTS OF *T. confusum*

FAA	Time (h)					Mean	Variation coefficient
	0.5	1	2	3	6		
THR	106	96	114	111	90	103	9.7
SER ^a	87	71	74	85	74	78	9.1
GLU	83	72	79	64	59	71	13.9
GLN	34	42	37	24	34	34	19.4
PRO ^b	119	135	97	109	104	113	13.0
GLY	101	106	88	111	138	109	17.0
ALA	121	138	158	188	161	153	16.3
VAL	83	100	91	95	89	91	7.0
ILE	108	101	93	99	136	107	15.5
LEU ^c	90	97	101	80	100	93	9.2
LYS	88	78	97	105	93	92	11.2
HIS ^d	94	96	83	90	89	90	5.4
ARG ^e	92	102	102	93	89	95	6.3

^a SER: serine.

^b PRO: proline.

^c LEU: leucine.

^d HIS: histidine.

^e ARG: arginine.

At 20 Gy, irradiation generally had little effect on FAA contents, except for glutamine (GLN) content at day 1 and glutamic acid (GLU) content at day 3.

The changes at 40 Gy were similar to those observed at 20 Gy, or somewhat greater for some FAAs, such as threonine (THR), valine (VAL), isoleucine (ILE) and GLU. After 13 d, the contents of all of the FAAs, except GLU and glycine (GLY), approximated the control values, indicating that the initial pool was restored.

The changes with time of the FAA contents after irradiation at 60 Gy were similar to the changes measured previously [2] at about the same dose in insects irradiated in a ¹³⁷Cs irradiator at a dose rate of 63 Gy/min instead of the 4.5 Gy/min used in this study. This indicated that the dose rate had no effect on changes in FAA contents. At 60 Gy, the contents of all of the FAAs declined with time except for lysine (LYS) content, which increased up to 140% after 13 d.

TABLE II. EFFECT OF LONG EXPOSURE TIMES TO NITROGEN ON THE FAA CONTENTS OF *T. confusum*

FAA	Time (h)			Mean	Variation coefficient
	9	12	15		
THR	133	138	148	140	5.2
SER	139	106	149	131	16.9
GLU	139	135	167	147	11.9
GLN	100	60	74	78	25.4
PRO	109	99	89	99	10.1
GLY	122	220	191	178	28.0
ALA	136	196	152	161	19.4
VAL	153	145	174	157	9.7
ILE	185	150	230	188	21.4
LEU	170	170	212	184	13.1
LYS	222	194	178	198	11.1
HIS	118	113	125	119	5.2
ARG	154	127	152	144	10.5

3.2. Effect of exposure to nitrogen

Exposure to nitrogen had a lethal effect on *T. confusum* depending on the exposure time. It killed 100% of the population after 17 h of exposure, 90% after 9 h, 23% after 6 h and 0% after 3 h [2].

Short exposures to nitrogen (0.5, 1, 2, 3 and 6 h) caused changes only in the contents of GLU and GLN, which decreased to 72% and 34%, respectively, and alanine (ALA), which increased up to 154%. The effect of anoxia was independent of the duration of exposure in this range of time (Table I). Longer exposures (9, 12 and 15 h) caused an increase in the contents of all of the FAAs except for GLN (79%) and proline (99%).

After 3 h of exposure, changes in FAA contents were measured at 3, 24 and 72 h in the study of the recovery of GLU, GLN and ALA. The results (Table II) showed that the time needed to restore these contents was about 24 h for GLU and ALA and 72 h for GLN.

TABLE III. RECOVERY OF THE FAA CONTENTS OF *T. confusum* AFTER 3 h OF EXPOSURE TO NITROGEN

FAA	TIME AFTER EXPOSURE (h)		
	3	24	72
GLU	64	95	117
GLN	24	72	111
ALA	188	97	95

4. DISCUSSION

4.1. Effect of irradiation

As shown previously [2], irradiation of insects at doses between 63 and 504 Gy produces essentially the same effect as a starvation treatment: the metabolically active FAAs, including the precursor 'primers' of the citric acid cycle (GLU and GLN), decrease with time, whereas the metabolically inert FAAs do not change (THR and HIS), or they increase in concentration (LYS), probably because new molecules are produced by the hydrolysis of muscle proteins. No restoration of the amino acid pool was noticed during the experiment.

Irradiation at 20 and 40 Gy, which has no effect on mortality, produces similar effects, but the changes are much less extensive than for higher doses and the FAA concentrations are restored within about five to ten days after treatment. It seems, therefore, that non-lethal doses of irradiation cause little damage to the digestive functions.

4.2. Effect of anoxia

In anoxic conditions, the pyruvate produced from the enzymatic conversion of glucose cannot be oxidized in the mitochondria and accumulates in the cytosol. The transfer of the amino acid group from GLU to pyruvate, which produces ALA, provides a means to control an excess of pyruvate, which may explain the changes observed in ALA and GLU for exposures under 6 h. The decrease in the GLN concentration may be due to the hydrolysis of GLN by the glutamase to restore GLU. It is not known why a relatively long time of 72 h is needed to restore the GLN concentration as compared with what is needed for GLU and ALA.

When anoxic conditions are maintained over a longer time (6–15 h), all of the FAAs except GLN accumulate, probably because some proteins are hydrolysed into new FAAs which cannot be degraded through Krebs's cycle.

5. CONCLUSIONS

When irradiation or exposure to nitrogen is at a non-lethal level, there is little change in the FAA concentrations, except for GLU and GLN, which have a central role in the degradation of the carbon 'skeletons' of amino acids. The GLU concentration declines and recovers its normal level for both treatments, whereas the GLN concentration changes specifically: with irradiation it rises sharply and falls shortly afterward toward the normal level, possibly because there is an accumulation of ammonium in the extracellular fluid, whereas for exposure to nitrogen it declines over some days to fulfil the demand of the GLU used to produce ALA from pyruvate.

When both treatments are carried out at a level causing lethal damage, the changes in FAA concentrations are quite different. Irradiation causes a global decrease, except for THR, HIS and, principally, LYS. Inversely, anoxia causes a global increase, except for GLN and PRO.

From this study it appears that the FAA distribution pattern in insects sampled in stores may be used practically for the identification of the kind of disinfestation treatments that have been applied to the product.

REFERENCES

- [1] BUSCARLET, L.A., AMINIAN, B., BALI, C., "Effect of irradiation and exposure to nitrogen on the mortality of adults of *Tribolium confusum* J. du Val.", Stored Product Protection (Proc. 4th Int. Conf. Tel Aviv, 1986), Agricultural Research Organization, Bet Dagan, Israel (1986).
- [2] BUSCARLET, L.A., RAVENEL, J.L., GUITTON, A., Effect of fasting and irradiation on the free amino acid content of *Tribolium confusum* J. du Val. (Coleoptera: Tenebrionidae), J. Stored Prod. Res. 22 (1986) 217.

Invited Paper

THE INHERITED STERILITY OF THE CORN BORER (*Ostrinia furnacalis* Guen.)

Y. Y. LI, H. Q. ZHANG, H. Z. LOU, C. D. ZHAO

Institute for Application of Atomic Energy,
Chinese Academy of Agricultural Sciences,
Beijing, China

Abstract

THE INHERITED STERILITY OF THE CORN BORER (*Ostrinia furnacalis* Guen.).

The inherited sterility of the Asian corn borer (*Ostrinia furnacalis* Guen.) irradiated with substerilizing doses of 200–300 Gy has been studied in Beijing, China. The irradiated male parents were substerile and females were fully sterile. The females were more sensitive to radiation. Experiments for mating competitiveness and release from field cages demonstrated that the irradiated male moths had a stronger level of competitiveness, and it was found that a ratio of 1:5 or more could suppress the native population effectively. The F_1 generation was more sterile than the parents and the sex ratio was changed to significantly more males than females. Inherited sterility could be maintained up to the F_2 generation and fertility recovered in the F_3 generation.

1. INTRODUCTION

High radiation doses, e.g. 400 Gy, reduced the competitiveness of the corn borer (*Ostrinia furnacalis* Guen.) significantly [1], with the result that the irradiated male moths released could not suppress the wild population effectively. In order to increase the mating competitiveness of the irradiated moths, the substerile insect technique for inherited sterility in the corn borer has been developed by the authors [2–4].

2. MATERIALS AND METHODS

The insects used in the experiments were a laboratory reared strain. The radiation source was a ^{60}Co source with a dose rate of 1.05–1.35 Gy/min. The pupae were put into polystyrene boxes and were irradiated two days before emergence.

2.1. Effect of radiation on corn borer parents and progeny

Irradiated male and female moths were mated with unirradiated female and male moths that emerged on the same day. Untreated male and female moths were paired as controls. Mating and depositing of eggs by adults were observed during the night.

The percentages of egg hatch were counted and recorded. Male pupae were irradiated at doses of 200, 300 and 400 Gy. The progeny larvae were reared individually and collectively on an artificial diet. The progeny were maintained up to the F₃ generation.

2.2. Mating competitiveness

Irradiated male and female moths and wild males and females were put together into glass jars in different ratios. In order to identify irradiated moths, they were marked with basic fuchsin and competitiveness was observed during the night. The number of spermatophores was counted under a microscope after the females died. The percentages of the sterile, substerile and fertile eggs were calculated when the eggs hatched.

2.3. Field cage release tests

Cages 4 m³ × 4 m³ × 2.8 m³ were used. In each cage, 28 stems of corn were planted, while 30 pairs of wild moths and male and female moths irradiated at different doses in ratios of 1:1, 1:5 and 1:10, respectively, were also put into the cages. The controls had no irradiated moths. The examinations were carried out at intervals of three or four days. The fully sterile, substerile and fertile eggs were counted. The number of corn borers, the damage and output were investigated during the different growth stages of corn.

3. RESULTS AND DISCUSSION

3.1. Effect of gamma radiation on corn borer

The sterility of corn borer was induced by gamma radiation. The higher the dose applied, the higher was the degree of sterility observed. In comparison with the control, the percentage of egg hatch decreased when the male parents were irradiated (Table I). However, male mating competitiveness was significantly decreased at a dose of 400 Gy or more (Table I). Thus, the lower doses, or partially sterilizing doses, were used in practice.

It has been difficult, so far, to separate in practice the male corn borers from the females. Thus, the effect of radiation on females should be considered. If substerile females were released, the additional reproduction would take place within the population. In our research, we observed that female moths were more sensitive to radiation, and when they were irradiated at 250 Gy they were almost fully sterilized (Table II). Males treated at 250–300 Gy were partially sterile and had stronger mating competitiveness, while females exposed to the same dose were sterile, suggesting that males and females could be released together and that the separation of males from females was not necessary [5].

TABLE I. EFFECT OF DIFFERENT DOSES OF GAMMA RADIATION ON EGG HATCH AND MATING PERCENTAGES

Dosage (Gy)	No. treated	Males mated (%)	No. of eggs	Egg hatch (%)
0 (<i>control</i>)	770	64.19	104 599	89.90
200	63	62.32	14 766 ^a	12.42 ^a
400	240	56.91	52 189	1.02
450	108	40.81	9 074	0.00
500	65	38.38	8 862	0.08
600	63	15.00	2 501	0.00
700	25	10.00	505	0.00

^a Irradiated at a dose of 250 Gy.

TABLE II. SENSITIVITY OF MALE AND FEMALE MOTHS TO GAMMA RADIATION

	Dosage (Gy)	No. of females	Egg hatch (%)
Male	0 (<i>control</i>)	250	89.90
	250	42	12.42
	400	143	1.02
	500	19	0.00
Female	250	22	0.16
	400	34	0.00
	500	4	0.00

3.2. Mating competitiveness and field cage release tests of substerile corn borer

The results of mating competitiveness showed (Tables III and IV) that the mating probability of treated and untreated males was almost equal and the mating competitiveness of substerile males was significantly higher than that of fully sterile males.

TABLE III. PROBABILITY OF MATING OF IRRADIATED AND UNIRRADIATED MALE AND FEMALE MOTHS

Dosage (Gy)	Ratio (N×S) ^a	No. of replications	No. of matings			Mating probability (N:S(φ))	Ratio (Nφ×Nσ:Sσ)	
			Nφ×Nσ	Nφ×Sσ	Sφ×Nσ			Sφ×Sσ
200	1:1×1:1	40	10	10	11	9	20:20=1:1	1:1
200	1:1×5:5	20	4	8	9	31	12:40=1:1.3	1:2
200	1:1×10:10	20	1	10	14	78	11:92=1:8.4	1:10
400	1:1×5:5	20	8	4	2	4	12:6=2:1	2:1

^a N: unirradiated; S: irradiated.

TABLE IV. MATING COMPETITIVENESS OF WILD AND IRRADIATED MOTHS

Year	Ratio (N♀:N♂:S♀:S♂)	No. of replications	Theoretical value				Practical value			
			N♀ x N♂	S♀ x N♂	N♀ x S♂	S♀ x S♂	N♀ x N♂	S♀ x N♂	N♀ x S♂	S♀ x S♂
1	1:1:1:1	40	1	1	1	1	1	1.1	1	0.9
	1:1:5:5	20	1	5	5	25	1	2.3	2	7.8
	1:1:10:10	20	1	10	10	100	1	14	10	78
	1:1:0:0	20	1							
2	1:1:0:5	20	1		5				2.4	
	1:1:5:5	20	1	5	5	25	1	5.4	3.2	17.8
	1:1:10:10	40	1	10	10	100	1	22.3	16	167.3
	1:1:0:0	20	1							

TABLE V. DATA FROM FIELD CAGE RELEASE TESTS

Year	Dosage (Gy)	Ratio (N♀:N♂:♂♀:♂♂)	No. of replicants	Total No. of egg masses	Fertile eggs		Theoretical value
					Egg mass	Index	
1	0 (control)	1:1	2	182	137	75.27	100
	200	1:1:1:1	2	198	68	34.34	25
	200	1:1:5:5	2	431	46	10.67	2.8
	200	1:1:5:10	2	620	46	7.42	1.5
2	0 (control)	1:1	2	22	14	63.4	100
	200	1:1:5:5	2	44	2	4.7	2.8
	200	1:1:10:10	2	74	3	4.2	0.9

TABLE VI. DATA FROM FIELD CAGE RELEASE TESTS

Dosage (Gy)	Ratio (N♀:N♂:SQ:SC)	No. of replicants	No. of corn stems	No. of leaves damaged	No. of tassels damaged	No. of ears damaged	No. of F ₁ moths	No. of larvae hibernating	Weight of corn (g)	Weight of corn/stem (g)
0 (control)	1:1	2	56	422	13	208	81	115	5305.7	94.7±40.7
200	1:1:1:1	2	56	282	4	103	36	13	5933.8	106.3±35.5
200	1:1:5:5	2	56	179	0	36	17	5	7442.5	132.9±36.8
200	1:1:5:10	2	56	200	3	33	21	8	6268.6	111.9±34.5

TABLE VII. SEX RATIO CHANGES IN THE F₁ GENERATION

Dosage (Gy)	Total No. of larvae reared	No. of larvae pupated		Ratio (♀:♂)
		♀	♂	
0 (control)	3237	560	589	1:1.07
250	1312	23	73	1:3.03
300	1036	19	90	1:4.74

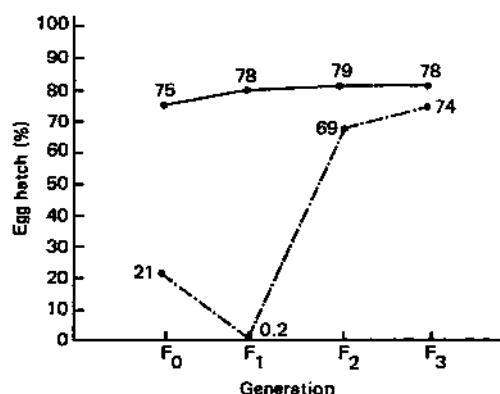

FIG. 1. Inherited sterility of irradiated parents and the recovery of fertility. (— — —): treatment; (—): control.

The result of field cage release tests showed that egg fertility decreased as the number of moths released increased (Table V). If the release ratio reached 1:5 or more, the corn borer population could be suppressed significantly. The damage to and output of corn and the density of the corn borer population were also investigated and for both the same conclusion was reached (Table VI).

3.3. Inherited sterility of irradiated parents and the recovery of fertility

Normal female moths, when mated with male moths irradiated at a dose of 250 Gy, produced the F₁ generation, and F₁ male moths also mated with normal females. The percentage of egg hatch was only 0.89%, almost fully sterile, and the F₁ progeny were more sterile than their parents. The larvae of the F₁ generation developed slowly, with greater mortality, and the sex ratio was changed (Table VII).

There were many more males than females. The changes would be more obvious if the radiation dose applied was increased. The fertility rate recovered when progeny were reared up to the F₃ generation (Fig. 1).

REFERENCES

- [1] ZHANG, H.Q., et al., Possibility of using the sterile insect technique to control corn borer, *At. Energy Sci. Technol.* **6** (1965) 548-556.
- [2] LACHANCE, L.E., "Genetic methods for the control of Lepidopteran pests. Status and potential", F₁ Sterility for Control of Lepidoptera Pests (Rep. Consultants Mtg Vienna, 1984), IAEA, Vienna, 1984.
- [3] NORTH, D.T., Inherited sterility in Lepidoptera, *Annu. Rev. Entomol.* **20** (1975) 167-182.
- [4] PROVERBS, M.D., NEWTON, J.R., LOGAN, D.M., Suppression of codling moth, *Laspeyresia pomonella* (Lepidoptera: Olethreutidae) by release of sterile and partially sterile moths, *Can. Entomol.* **110** (1978) 1095.
- [5] ZHANG, H.Q., et al., The inherited sterility of the corn borer (*Ostrinia furnacalis* Guenée), *Chin. Agric. Sci.* **1** (1980) 70-73.

**PARENTAL AND INHERITED STERILITY INDUCED
BY GAMMA RADIATION IN MALE MOTHS
OF THE MAIZE BORER,
Chilo partellus (Swinhoe)**

A.R. BUGHIO

Atomic Energy Agricultural Research Centre,
Tandojam, Pakistan

Abstract

PARENTAL AND INHERITED STERILITY INDUCED BY GAMMA RADIATION IN MALE MOTHS OF THE MAIZE BORER, *Chilo partellus* (Swinhoe).

The F₁ generation males of *Chilo partellus* (Swinhoe) inherited sterility from their P₁ males irradiated at substerilizing doses of gamma radiation. The fecundity of normal wild females crossed either with P₁ males, irradiated at 5, 10 and 15 kR, or their F₁ male progeny was not significantly different from the control. The fertility of such pairings was, however, significantly reduced, but it was always greater in P₁ out-crosses than in F₁ out-crosses. There was no significant difference in the percentages of eggs that were embryonated in radiation treatments of P₁ male and female moths. However, embryonation was significantly reduced when F₁ males were obtained from 10 kR treatment of P₁ males. Dominant lethals acted late in the embryonic stage in eggs obtained from P₁ male out-crosses, but relatively earlier in eggs obtained from F₁ male out-crosses. Successful matings in the control and at 5, 10 and 15 kR treatments of P₁ males did not differ significantly, but the mating ability of F₁ males (at 10 kR) was significantly reduced when compared with the control. The longevity of P₁ and F₁ male moths was unaffected. The number of post-embryonic survivals was greater in the F₁ generation than in F₂, and the larval period was extended in both generations, with the sex ratio distorted in favour of male moths.

1. INTRODUCTION

The sterile insect release method of suppressing or controlling insect populations was among the outstanding recent contributions to economic entomology. The success of this method of insect pest control depends, in fact, on the production of sterile males which should be active enough to compete effectively with normal males in finding their mates. Lepidopterous species which have been evaluated for the effects of irradiation require relatively large doses (16 000–50 000 rad)¹ of gamma radiation to induce sterility [1]. Mating competitiveness and longevity are adversely affected by sterilizing doses, but competitive moths will result when doses are substerilizing [2]. Moreover, 'individuals' treated at substerilizing doses produce offspring which are nearly or completely sterile. This phenomenon is known as inherited, or F₁, sterility.

¹ 1 rad = 1.00 × 10⁻² Gy.

Proverbs [3] was the first to report the presence of inherited sterility in the F_1 progeny of the codling moth (*Carpocapsa pomonella*) when paternal male moths, irradiated as pupae at 30 kR,² were mated with non-irradiated females. Other lepidopterous species which have been the subjects of such studies include *Paramyelois transitella* [4], *Trichoplusia ni* [5], *Diatraea saccharalis* [6, 7], *Heliothis virescens* [8, 9], *Ephestia cautella* [10–12], *Pectinophora gossypiella* [13, 14], *Spodoptera exigua* [15], *Galleria mellonella* [16], *Ostrinia nubilalis* [17], *Agrotis ipsilon* [18], etc.

Similar work, at least to the author's knowledge, has not yet been reported on *Chilo partellus*. This pest is of considerable economic importance in Asia and Africa. It mainly attacks maize and sorghum and also creates problems in rice, sugarcane and pearl millet. In view of the economic importance of the pest, and the difficulties encountered in controlling lepidopterous borers through conventional methods, it would be of great interest to ascertain the effects of substerilizing doses on parent (P_1) and F_1 generations and the feasibility of applying F_1 sterility, alone or in conjunction with other methods of insect pest control, for the suppression of the pest population under laboratory and field conditions. The present paper reports on the preliminary findings of the effects of substerilizing doses of gamma radiation on the reproductive biology of P_1 and F_1 generations. The studies also include induced dominant lethality and post-embryonic survivals in the F_1 and F_2 generations.

2. MATERIALS AND METHODS

2.1. Pre-irradiation

Egg masses were collected from a laboratory culture maintained on a modified artificial diet [19]. The hatched larvae were reared on a host plant (maize) for 15 d and were then transferred to an artificial diet until pupation. Pupae removed from the rearing tubes were sexed and kept in separate Petri dishes on slightly moistened paper towels for emergence.

2.2. Irradiation

Emergent male and female moths were irradiated in air with a ^{60}Co panoramic source of 250 Ci.³ The dose rate was 78 R/min at a distance of 13 cm. The temperature of the room during irradiation fluctuated between 26 and 28°C.

² 1 röntgen (R) = 2.58×10^{-4} C/kg.

³ 1 curie (Ci) = 3.70×10^{10} Bq.

2.3. Post-irradiation

Irradiated male and female moths were separately crossed with non-irradiated female and male moths in such a way that two male moths, either irradiated or non-irradiated, were kept with one female in glass chimney cages which contained young maize plants and wax paper strips as ovipositional sites. Cotton wicks soaked in a 10% sucrose solution were also provided as sources of food and drinking water. At least 20 such cages were maintained for each treatment. Normal pairs were also kept to serve as the controls. F_1 crosses were made in a similar fashion. Moths used for irradiation purposes were taken from laboratory culture, but non-irradiated moths were reared from the field collected larvae, which pupated in the laboratory within one to two days of collection.

2.4. Fecundity, fertility, mating and embryonic development

To ensure that the eggs laid by unmated females are not included in any egg samples used for hatchability purposes, the eggs collected from each treatment, as well as of each replicate, were stored in separate containers. After death females were dissected and the presence of spermatophore in bursa-copulatrix was used as the criterion that the females had only mated, but were not necessarily fertilized. Fertilization of the females was confirmed when the eggs laid by mated females were embryonated. All of the fecundity and fertility figures are, therefore, based on the counts of the total number of eggs laid by mated and fertilized females. Observations on the embryonic development and categorization of unhatched eggs for induced dominant lethality were made as reported earlier [19, 20].

2.5. Light, temperature and relative humidity

All of the experiments were carried out in the laboratory, where a light regimen of 14 h of darkness alternated with 10 h of light from daylight fluorescent tubes. The temperature and relative humidity fluctuated between 25 and 26°C and 70 and 75%, respectively.

2.6. Statistical analysis

The data were subjected to analysis of variance and Duncan's Multiple Range Test was used to compare unequal means.

TABLE I. FECUNDITY AND FERTILITY OF PARTIALLY STERILE *C. partellus* MOTHS IN P₁ AND F₁ CROSSES

Dose to P ₁ males (kR)	Type of cross*	No. of cages	Average No. of eggs/mated female**	Per cent larval hatch
<i>P₁ crosses</i>				
0	NM×NF (control)	20	365 ^a	88.16 ^a
5	TM×NF	25	392 ^a	50.01 ^b
	TF×NM	25	353 ^a	0.00 ^d
10	TM×NF	25	371 ^a	8.28 ^c
	TF×NM	25	238 ^b	0.00 ^d
15	TM×NF	25	384 ^a	0.26 ^d
<i>F₁ crosses</i>				
0	NM×NF (control)	30	366 ^a	85.81 ^a
5	TM×NF	35	367 ^a	38.93 ^b
10	TM×NF	35	349 ^a	3.22 ^c

* N: normal; M: male; F: female; T: treated; P₁ or F₁ obtained from treated parents.

** Figures in the same column followed by different superscript letters are significantly different from each other at the 1% level.

3. RESULTS

3.1. Fecundity and fertility

The fecundity of non-irradiated females mated with either P₁ males irradiated at 5, 10 and 15 kR or their male progeny was not significantly different from that of the control (Table I). The fecundity of P₁ females receiving a dose of 5 kR and mated with normal males also did not differ from that of the control, but it was significantly reduced, to 238 eggs/female when P₁ females were irradiated at 10 kR. The fertility (larval hatch) of P₁ and F₁ males mated separately with normal females was significantly reduced as compared with the controls and there were also significant differences between the treatments. The fertility of P₁ males was always higher than that of F₁ males. No larval hatch, however, was recorded in egg samples collected from crosses of P₁ females mated with normal males.

TABLE II. EMBRYONIC DEVELOPMENT IN UNHATCHED *C. partellus* EGGS COLLECTED FROM P₁ AND F₁ CROSSES

Dose to P ₁ males (kR)	Type of cross	Percentage of unhatched eggs that were scored as			Eggs embryonated (%)
		Fully developed	Under-developed	Undeveloped	
<i>P₁ crosses</i>					
0	NM×NF (control)	4.58	4.12	3.14	96.86 ^a
5	TM×NF	35.23	10.62	4.14	95.86 ^a
	TF×NM	3.11	82.01	14.88	85.12 ^a
10	TM×NF	59.57	23.89	8.26	91.74 ^a
	TF×NM	4.23	82.08	13.69	85.31 ^a
15	TM×NF	62.90	28.39	9.45	91.55 ^a
<i>F₁ crosses</i>					
0	NM×NF (control)	6.25	4.31	3.63	96.37 ^a
5	TM×NF	29.63	20.16	11.28	88.72 ^a
10	TM×NF	32.55	25.99	38.24	61.76 ^b

Note: See Table I for explanation of abbreviations and superscript letters.

3.2. Embryonation and dominant lethality

There was no significant difference in eggs that were embryonated in the control group and in groups from radiation treatments of P₁ male and female moths (Table II). However, the percentage of embryonated eggs was significantly reduced when F₁ males, obtained from 10 kR treated P₁ males, were mated with normal females. Dominant lethals acted late in the embryonic stage in eggs obtained from P₁ male out-crosses, but relatively earlier in eggs obtained from P₁ female and F₁ male out-crosses. The percentage of lethal embryos was dependent on the dose.

3.3. Mating and adult longevity

The number of successful matings (matings in which spermatophore with sperm was transferred) in the control group and in 5, 10 and 15 kR treated P₁ males were not significantly different from each other (Table III). The mating ability of F₁

TABLE III. MATING CAPABILITY/RECEPTIVITY AND ADULT LONGEVITY OF PARTIALLY STERILE *C. partellus* MOTHS IN P₁ AND F₁ CROSSES

Dose to P ₁ males (kR)	Type of cross	Percentage of males*			Unmated females (%)	Longevity of irradiated male or female moths (d)
		1	2	3		
<i>P₁ crosses</i>						
0	NM×NF (control)	85.0 ^a	0.0	0.0	15.0	5.78 ^a
5	TM×NF	92.0 ^a	0.0	0.0	8.0	5.60 ^a
	TF×NM	92.0 ^a	0.0	0.0	8.0	5.54 ^a
10	TM×NF	88.0 ^a	0.0	0.0	12.0	5.42 ^a
	TF×NM	72.0 ^b	0.0	0.0	28.0	5.03 ^a
15	TM×NF	88.0 ^a	0.0	0.0	12.0	5.90 ^a
<i>F₁ crosses</i>						
0	NM×NF (control)	83.33 ^a	0.0	0.0	16.67	5.55 ^a
5	TM×NF	88.57 ^a	0.0	0.0	11.43	5.32 ^a
10	TM×NF	74.29 ^b	0.0	0.0	25.71	5.00 ^a

* 1: males transferring spermatophore with sperm; 2: same, except without sperm; 3: sperm transferred without spermatophore.

Note: See Table I for explanation of abbreviations.

Figures in the same column followed by different superscript letters are significantly different from each other at the 5% level.

males, whose male parents received 10 kR, was significantly reduced as compared with normal and F₁ males obtained from treatment at 5 kR. None of the male moths in any treatment/generation was found to transfer either spermatophore without sperm or sperm without spermatophore. The longevity of males and females was not affected in the P₁ and F₁ generations at any dose to P₁ male or female moths.

3.4. Post-embryonic survival

Results regarding the post-embryonic survivals of F₁ and F₂ generations are presented in Table IV. When P₁ males (irradiated at 5 and 10 kR) and their male progeny were crossed with normal females, the percentages of F₁ and F₂ larvae transforming into pupae and larvae reaching adult stage were significantly reduced

TABLE IV. POST-EMBRYONIC SURVIVAL OF THE F₁ AND F₂ GENERATIONS OF *C. partellus* WHOSE P₁ MALES WERE IRRADIATED AT SUBSTERILIZING DOSES OF GAMMA RADIATION

Dose to P ₁ males (kR)	No. of larvae placed	Percentage of larvae transformed into pupae*	Percentage of normal adults emerged from pupae		Ratio of females to males:	Total per cent adult emergence		Percentage of larvae reaching adult stage	Mean larval period (d)
			Male	Female		Normal	Malformed		
<i>F₁ generation (P₁ male × normal female)</i>									
0	300	86.67 ^a	53.85	46.15	1.17:1	100.00 ^a	0.00	86.67 ^a	23.59 ^b
5	300	60.00 ^b	55.00	41.67	1.32:1	96.67 ^a	1.66	58.00 ^b	22.32 ^c
10	300	45.33 ^c	55.88	19.12	2.92:1	75.00 ^b	14.70	34.00 ^c	25.01 ^a
15	100	0.00 ^d	—	—	—	—	—	—	—
<i>F₂ generation (F₁ male × normal female)</i>									
0	400	88.00 ^a	51.42	46.02	1.12:1	97.44 ^a	0.00	85.75 ^a	24.12 ^c
5	400	48.25 ^b	46.11	24.35	1.89:1	70.46 ^b	10.88	34.00 ^b	28.14 ^b
10	400	38.50 ^c	37.66	9.74	3.87:1	47.40 ^c	23.38	18.25 ^c	29.41 ^a

* Figures in the same column followed by different superscript letters are significantly different from each other at the 5% level.

as compared with the control. None of the F_1 larvae reached the pupal stage when P_1 males, which received a 15 kR treatment, were crossed with normal females. F_1 and F_2 larvae from 10 kR treated P_1 males required significantly more time to become pupae than did the control. The lower dose (5 kR) given to P_1 males, however, extended the larval period and reduced adult emergence in the F_2 generation, but not in the F_1 generation. There were more post-embryonic survivals in the F_1 generation than in the F_2 generation. The sex ratio was distorted in favour of male moths in both of the generations and its intensity was dependent on dose and generation.

4. DISCUSSION

Present investigations have demonstrated that the deleterious effects induced by gamma radiation in parents were transmitted and expressed in the progeny of maize borer, *C. partellus*, resulting in greater sterility in F_1 generation males than P_1 males. Irradiation of male parents did not affect their mating success, but the mating ability of F_1 (10 kR) males was impaired. Dominant lethal mutations were induced in gametes, but they were not hindered, in any case, in participating in fertilization, and deaths of heterozygotes in F_1 eggs were usually observed late in the embryonic stage. The viability of embryos that survived to the larval stage was reduced and there were more post-embryonic deaths in the F_1 generation than in F_2 . These results are more or less consistent with and support those reported for other species of Lepidoptera [5-8, 11, 16]. However, the literature also contains a few contrasting reports on the expression of dominant lethals and the sex ratio in lepidopterous species. For example, Walker and Quintana-Muniz [21] reported that in sugarcane borer, *Diatraea saccharalis*, most of the embryos from irradiated sperm or oocytes die early in development. With the exception of this species, deaths of embryos from irradiated gametes have been reported late in development in most of the species of Lepidoptera [11, 20, 22] and in at least one species of Heteroptera (e.g. the large milkweed bug), which, like lepidopterous species, possesses holokinetic chromosomes (diffused centromeres) [23]. There is one species of Lepidoptera (*Trichoplusia ni*) for which it has been stated that irradiation had no apparent effect on the sex ratio of the F_1 population that survived to maturity [5].

REFERENCES

- [1] LACHANCE, L.E., SCHMIDT, C.H., BUSHLAND, R.C., "Radiation induced sterilization", Pest Control: Biological, Physical and Selected Chemical Methods (KILGORE, W.W., DOUTT, R.L., Eds), Academic Press, New York and London (1967) 147-196.
- [2] NORTH, D.T., Inherited sterility in Lepidoptera, Annu. Rev. Entomol. 20 (1975) 167-182.
- [3] PROVERBS, M.D., Progress on the use of induced sexual sterility for the control of the codling moth, *Carpocapsa pomonella* (L.) (Lepidoptera:Olethreutidae), Proc. Entomol. Soc. Ont. 92 (1962) 5-11.

- [4] HUSSEINY, M., MADSEN, H.F., Sterilization of the navel orangeworm, *Paramyelois transitella* (Walker) by gamma radiation (Lepidoptera:Phycitidae), *Hilgardia* **36** (1964) 113-137.
- [5] NORTH, D.T., HOLT, G., Inherited sterility in progeny of irradiated male cabbage loopers, *J. Econ. Entomol.* **61** (1968) 928-931.
- [6] WALKER, D.W., QUINTANA-MUNIZ, V., Inherited partial sterility among survivors from irradiation-eradication experiments, *J. Econ. Entomol.* **61** (1968) 318-319.
- [7] SANFORD, J.W., Inherited sterility in progeny of irradiated male sugarcane borers, *J. Econ. Entomol.* **69** (1976) 456-458.
- [8] PROSHOLD, F.I., BARTELL, J.A., Inherited sterility in progeny of irradiated male tobacco budworm: Effects on reproduction, developmental time, and sex ratio, *J. Econ. Entomol.* **63** (1970) 280-285.
- [9] GUERRA, A.A., GARCIA, R.D., Tobacco budworm: Parental and inherited sterility induced by reserpine and gamma-irradiation, *J. Econ. Entomol.* **69** (1976) 339-342.
- [10] AHMED, M.S.H., AL-HAKKAK, Z., AL-SAQUR, A., "Exploratory studies on the possibility of integrated control of the fig moth, *Ephestia cautella* Walk.", Application of Induced Sterility for Control of Lepidopterous Populations (Proc. Panel Vienna, 1970), IAEA, Vienna (1971) 1-6.
- [11] AMOAKO-ATTA, B., DENELL, R.E., MILLS, R.B., Radiation-induced sterility in *Ephestia cautella* (Walker) (Lepidoptera:Pyralidae): Recovery of fertility during five generations after gamma-irradiation, *J. Stored Prod. Res.* **14** (1978) 181-188.
- [12] GONEN, M., CALDERON M., Effect of gamma-radiation on *Ephestia cautella* (Walk.) (Lepidoptera:Phycitidae). II. Effects on progeny of irradiated males, *J. Stored Prod. Res.* **7** (1971) 91-96.
- [13] CHENG, W.Y., NORTH, D.T., Inherited sterility in the F₁ progeny of irradiated male pink bollworms, *J. Econ. Entomol.* **65** (1972) 1272-1275.
- [14] HENNEBERRY, T.J., CLAYTON, T., Effects on reproduction of gamma irradiated laboratory reared pink bollworms and their F₁ progeny after matings with untreated laboratory reared or native insects, *J. Econ. Entomol.* **74** (1981) 19-23.
- [15] DEBOLT, J.W., WRIGHT, F.K., Beet armyworm: Inherited sterility produced by irradiation of pupae or adults, *J. Econ. Entomol.* **69** (1976) 336-338.
- [16] NIELSEN, R.A., BRISTER, C.D., Induced genetic load in descendants of irradiated greater wax moths, *Ann. Entomol. Soc. Am.* **73** (1980) 460-467.
- [17] NABORS, R.A., PLESS, C.D., Inherited sterility induced by gamma-radiation in a laboratory population of the European corn borer, *J. Econ. Entomol.* **74** (1981) 701-702.
- [18] ELNAGAR, S., MEGAHED, M.M., SALLAM, H.A., IBRAHIM, S.M., Inherited sterility among *Agrotis ipsilon*: Laboratory populations exposed to gamma-radiation, *Insect Sci. Appl.* **5** (1984) 501-504.
- [19] BUGHIO, A.R., AKBAR, S.S., QURESHI, Z.A., Rearing and biology of maize borer, *Chilo partellus* (Swinhoe) (Lepidoptera:Pyralidae), *Pakistan. J. Zool.* **9** (1977) 145-156.
- [20] BUGHIO, A.R., Embryonic development and induced dominant lethality in F₁ eggs of *Chilo partellus* (Swinhoe), *Radiat. Res.* **67** (1976) 299-304.
- [21] WALKER, D.W., QUINTANA-MUNIZ, V., Mortality staging of dominant lethals induced in the F₁ generation of sugarcane borer, *Diatraea saccharalis* (F.), *Radiat. Res.* **36** (1968) 138-143.
- [22] TAZIMA, Y., Considerations on the changes in observed mutation rates in the silkworm after irradiation of various stages of gametogenesis, *Jpn J. Genet. (Suppl.)* **36** (1960) 50-60.
- [23] LACHANCE, L.E., DEGRUGILLIER, M., LEVERICH, A.P., Cytogenetics of inherited partial sterility in three generations of the large milk-weed bug as related to holokinetic chromosomes, *Chromosoma* **29** (1970) 20-21.

Poster Presentation

IAEA-SM-301/2P

RADIATION INDUCED GENETIC DAMAGES INFLUENCING THE SUPPRESSIVE EFFECT OF INHERITED STERILITY IN THE CODLING MOTH

A.I. ANISIMOV, N.V. LAZURKINA,
A.N. SHVEDOV
All-Union Institute of Plant Protection,
Leningrad,
Union of Soviet Socialist Republics

The phenomenon of inherited sterility (IS) and its relation to radiation induced chromosome aberrations has been known since the 1930s [1, 2]. Only in the 1960s did Proverbs suggest using IS in pest control [3]. This method is specific for species with polycentric chromosomes [4].

We are interested in the genetic basis of IS and its manifestation in the codling moth. Studies of insect lines over several generations after gamma radiation of the parents showed that different classes of chromosome rearrangements were the basis of IS. The amount of sterility depends on the dose and the sex treated. There are two types of sterility. The first type is fully sterile pairs of insects that either do not oviposit eggs or produce eggs without signs of visible embryonic development. The second type is partly sterile pairs that produce eggs in which the embryos develop normally and hatch or die during embryonic development. These two types of sterility have a different genetic basis.

The fully sterile pairs can further be divided into two groups: coupling and non-coupling. When males are irradiated and their sons mated with untreated females, the frequency of non-coupling pairs in the F_1 generation is 90% at a dose of 30 krad.¹ Certainly, this effect will reduce the efficiency of IS in pest control. The induced genetic rearrangements, leading to loss of sexual activity in the males, are inherited by fertile insects in the F_1 generation and are realized in the back-crosses (F_b). The loss of sexual activity of F_1 generation females is also observed, but on a rather smaller scale.

The frequency of fully sterile F_1 males that mated increased with the dose of radiation. This effect too will reduce the efficiency of IS in pest control. The males from this group were often found to be deficient in sperm transfer or in the capacity of their sperm to fertilize eggs. The frequency of such males in the F_b generation was very low. The genetic damages, producing similar effects in females, were found to occur at a lower frequency in the offspring of irradiated males. As a whole,

¹ 1 rad = 1.00×10^{-2} Gy.

induced genetic changes, leading to the sterility of the first type, decreased the efficiency of the method. We found that the competitiveness of F_1 males was 0.04 as compared with the normal males if we used a dose of 30 krad, and their effect in decreasing the reproductive potential of the population has no significance.

The decrease in this potential is due to inherited changes that are expressed in the post-zygotic stages, leading to the sterility of the second type. After a 10 krad treatment, 40% of the F_1 males exhibited the second type of sterility. They were not similar in the level of sterility, but most of them had an extremely low level of fertility.

Some of the eggs oviposited by pairs with the second type of sterility died without signs of visible embryonic development. We do not consider such deaths as being post-zygotic. We obtained a high frequency of such eggs oviposited by irradiated females. The frequency changed very little if we irradiated males, but was rather high in their sons. Generally, the damage causing this type of death of the eggs was not inherited by F_1 females or by F_b generation males and females.

The frequency of eggs dying during embryonic development becomes greater with an increase in the dose after female irradiation than after male irradiation. This kind of sterility in F_1 males and females is much higher than in the irradiated fathers. The induced chromosome aberrations, which are the basis of this type of sterility, are not inherited by the offspring of irradiated females owing to the special features of oogenesis. The increase in the frequency of embryonic deaths in the F_1 generation was only in the offspring of irradiated males, but it was inherited by F_b generation offspring of F_1 females as well as the F_1 males. The level of embryonic deaths in the F_b generation depends on the level in the F_1 generation, but is extremely variable between individuals (from 0 to 100%).

A dose of 10 krad seemed to be effective in producing a high level of post-zygotic induced genetic damages in the F_1 generation. However, it did not provide full sterilization of females. It would be useful to be able to separate the sexes or to increase the dose. In addition, the sterility level of males irradiated at a dose of 10 krad is not high. The problem of dose optimization also arises. In order to consider the impact of various factors, such as changes in the sex ratio of the progeny, the frequency of post-embryonic deaths and a decrease in competitiveness, we must use simulated models.

REFERENCES

- [1] ASTAUROV, B., FROLOVA, S.L., *Biol. J.* 4 5 (1935) 861-888 (in Russian).
- [2] OSTRYAKOVA-VARSHAVER, V.P., *Biol. J.* 6 4 (1937) 816-836 (in Russian).
- [3] PROVERBS, M.D., *Proc. Entomol. Soc. Ontario* 9 (1962) 5-11.
- [4] LACHANCE, L.E., "Genetic methods for the control of Lepidopteran pests: Status and potential", *F₁ Sterility for Control of Lepidoptera Pests* (Rep. Consultants Mtg Vienna, 1984), IAEA, Vienna, 1984.

ISOTOPES AS LABELS

(Session 8)

Chairman

J.M.M. WALDER

Brazil

STUDIES ON THE PREDATOR-PREY RELATIONSHIP BETWEEN *Oecophylla smaragdina* AND *Helopeltis theobromae* USING THE RADIOTRACER TECHNIQUE

P.K. CHIN*, A.B. SIPAT**, K.C. KHOO*

* Department of Plant Protection

** Department of Biotechnology

Universiti Pertanian Malaysia,
Serdang, Selangor,
Malaysia

Abstract

STUDIES ON THE PREDATOR-PREY RELATIONSHIP BETWEEN *Oecophylla smaragdina* and *Helopeltis theobromae* USING THE RADIOTRACER TECHNIQUE.

The mirid *Helopeltis theobromae* Miller is a serious pest of cocoa in Peninsular Malaysia. The presence of the red tree ant *Oecophylla smaragdina* has been commonly observed to be associated with a decrease in mirid damage. The first experiment reported here established that the ant was indeed associated with a definite decrease in damage levels. In the second experiment, fourth-fifth instar nymphs labelled with ^{35}S -sulphate were released onto isolated cocoa branches bearing colonies of *O. smaragdina* in the field. Radioactivity exceeding background levels was detected in all 'castes' of ants 24 h later. In the third experiment, it was found that first-second and fourth-fifth instar nymphs responded to the presence of the ants by dropping from the branch, probably as an escape mechanism. A proportion of the fourth-fifth instar nymphs falling from branches infested by ants was injured, whereas no injured mirids were found among those falling from uninfested branches. This suggests active predatory behaviour by the ants. No fallen first-second instar nymphs were found to be injured irrespective of whether ants were present or not. Labelling the nymphs (fourth-fifth instar) with ^{35}S -sulphate did not seem to increase their propensity to drop either in the presence or absence of ants.

1. INTRODUCTION

Mirids (Hemiptera:Miridae) are serious pests of cocoa. In Peninsular Malaysia the common species found is *Helopeltis theobromae* Miller. This insect feeds by a piercing and sucking action. The adults and nymphs attack both the cocoa pod and shoot, resulting in direct physical damage which leads to secondary infection of the lesions by various fungi [1]. Control of the pest can be achieved using chemicals such as propoxur, gamma-HCH and pyrethroids. We are, however, looking at the possibility of using biological control in the management of the pest so as to minimize the use of chemicals.

In Malaysia, it is commonly observed that the presence of ants such as *Oecophylla smaragdina* Fabr. and *Dolichoderus thoracicus* Smith on cocoa trees reduces the incidence and intensity of mirid damage. There is, however, no proper study of this relationship on record. We are therefore investigating this phenomenon, concentrating on the role of *O. smaragdina* in the control of mirid damage to cocoa. *Oecophylla smaragdina* is commonly called the red tree ant. It is a predatory insect and has a very aggressive behaviour, attacking any intruder, often in groups. The results of our study are presented in this paper.

2. MATERIALS AND METHODS

2.1. General

2.1.1. Breeding of mirid nymphs

Adult insects were obtained from Prang Besar Estate, Selangor, and allowed to breed in sleeve-caged cocoa pods in the University's cocoa field. Nymphs which emerged from eggs laid in these pods were collected and reared in the laboratory on cocoa pod slices after the technique devised by Rita and Khoo [2].

2.1.2. Labelling of nymphs

The nymphs were labelled using the feeding bell described by Teo et al. [3] (Fig. 1). Five nymphs were placed in each feeding bell and starved for eight hours. At the end of this period, a 1.0 mL solution of 5% wt/vol. sucrose and $17 \mu\text{Ci}^1$ of ^{35}S -sulphate (Amersham, UK) was injected through the plastic lid into the food compartment. The nymphs were observed to start feeding through the Parafilm barrier. The feeding time was two hours and under these conditions each insect on average received a dose of 16 000 counts per minute (counts/min).

2.1.3. Determination of radioactivity

Each insect was first 'digested' in 0.25 mL Protosol (New England Nuclear, USA) in a scintillation vial. To this was then added 5.0 mL of scintillation fluor (toluene containing 0.5% wt/vol. 2,5-diphenyloxazole). The sample was allowed to stabilize overnight in the dark before counting was carried out using a Packard 460C scintillation counter. The counting efficiency, determined by the sample channel ratio method, ranged from 91 to 92%. A sample blank containing an unlabelled insect was also included.

¹ 1 curie (Ci) = 3.70×10^{10} Bq.

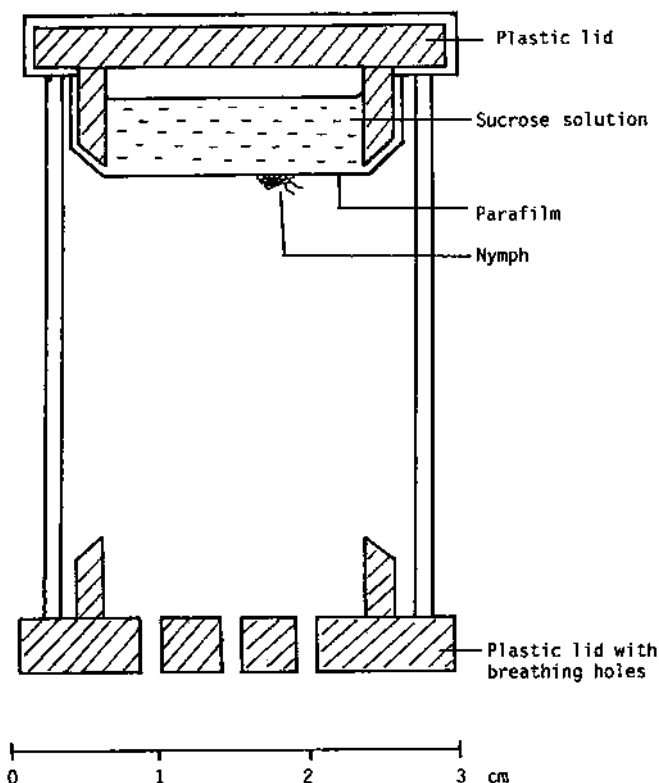

FIG. 1. Diagram of the feeding bell for the labelling of *H. theobromae* nymphs.

2.2. Influence of *O. smaragdina* on the degree of mirid damage in the field

Although it is generally observed that the presence of *O. smaragdina* on cocoa trees resulted in less damage by *H. theobromae*, there are no supporting data available. A field survey was therefore carried out to ascertain this observation.

A plot of 46 trees was selected in the University's cocoa field. Those trees which had one or more nests of *O. smaragdina* were scored as positive and negative if they had none. Cocoa pods greater than 2 cm in length were examined for the severity of mirid damage and scored as follows:

- Damage category 1: fewer than 20 lesions,
- Damage category 2: lesions scattered all over the pod which did not coalesce,
- Damage category 3: dense lesions with tendency to coalesce.

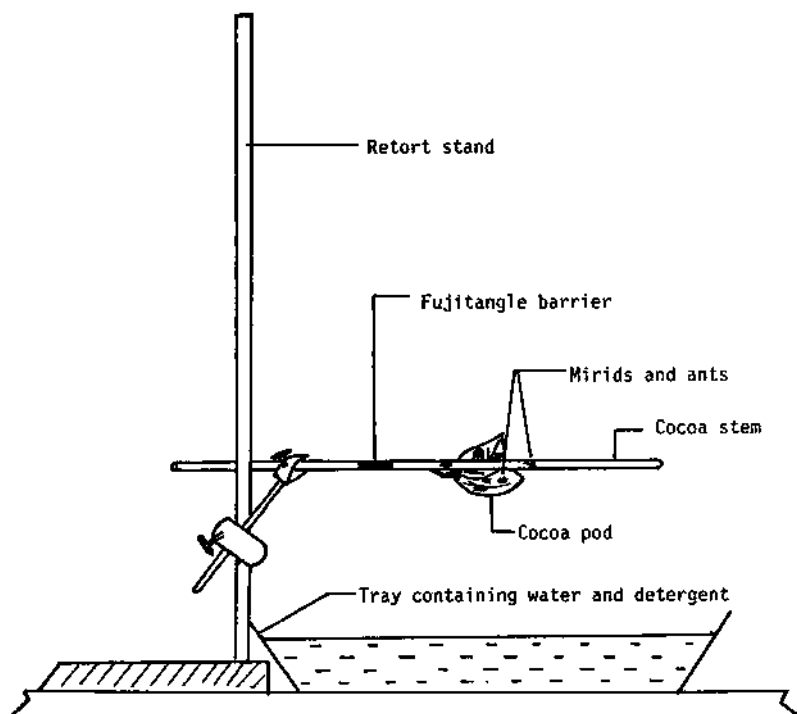

FIG. 2. Diagram of the experimental set-up for the study of the behavioural responses of mirid nymphs to the presence of *O. smaragdina*.

2.3. Radioisotope labelling study

This study was carried out to determine if there exists a predator-prey relationship between *O. smaragdina* and *H. theobromae* by using ^{35}S to tag the latter insect. A single branch of a cocoa tree containing an active nest of *O. smaragdina* was isolated by ringing the proximal end with 'Fujitangle' (a sticky substance) and by removing other branches that were in contact with it. A large plastic sheet was laid below the branch to catch any falling insects. Fujitangle was applied to the perimeter of the sheet to prevent the fallen insects from walking off. Sixty fourth-fifth instar nymphs labelled with ^{35}S were released onto this branch. After 24 h, the branch was cut off and placed in a large plastic bag. The ants were killed and sorted according to their 'castes'. Where the number of 'individuals' in each category exceeded 25, 25 individuals were selected at random and separately measured for radioactivity. Each individual was scored as being radiolabelled if it produced a count

rate higher than 100 counts/min. The blank count rate ranged from 50 to 70 counts/min. This experiment was carried out with four separate branches, each containing a nest.

2.4. Behavioural response of mirid nymphs to the presence of *O. smaragdina*

During the course of the previous experiment it was observed that as much as 50% of the mirids released onto the branch had fallen onto the plastic sheet below. This behaviour could be a response to the presence of the ants and the hypothesis was tested in the present experiment. In addition, the experiment was also used to examine if labelling of the mirids contributed to the dropping behaviour.

The experimental set-up was as shown in Fig. 2 and comprised a piece of cocoa stem (45 cm long and 1.5 cm in diameter) to which a 13 cm long cocoa pod was nailed. By means of a retort stand, the stem was held over a tray containing water to which a little detergent was added. A Fujitangle barrier on the stem prevented the experimental insects from escaping down the retort stand. Any mirid falling off the set-up drowned in the tray of water and was recorded. The number of injured mirids among those which fell off was also noted. There were four treatment combinations, with each combination consisting of the presence or absence of ants and labelled or unlabelled mirids. Fifteen fourth-fifth instar mirids were placed on the cocoa pod. Where ants were required, 25 large workers were introduced. There were three replicates. The experiment was repeated using first-second instar nymphs, but these were not labelled.

3. RESULTS

3.1. Influence of *O. smaragdina* on the degree of mirid damage in the field

Table I summarizes the results of the survey. A test for independence in a contingency table showed that the damage categories were dependent on the presence or absence of the ants ($\chi^2 = 57.10$, degrees of freedom (df) = 2, $P < 0.01$). In the presence of colonies of *O. smaragdina*, only 3.6% of the pods were in damage categories 2 and 3, whereas in the absence of the ants 34.5% of the pods were in the same categories. The data show that the presence of the ants does help to reduce the damage caused by *H. theobromae*.

3.2. Radioisotope labelling study

The results are summarized in Table II. The large worker caste contained the highest number of individuals in three of the four nests examined. The data show that this group, which does most of the foraging, had become radioactive by coming into contact with the radiolabelled mirid nymphs. The other castes were also labelled and

TABLE I. INFLUENCE OF THE PRESENCE OF *O. smaragdina* COLONIES ON THE DEGREE OF MIRID DAMAGE TO COCOA PODS

Ants	Number of pods according to damage category			Total
	1	2	3	
Present	164 (96.5)	2 (1.2)	4 (2.4)	170
Absent	171 (65.5)	34 (13.0)	56 (21.5)	261
<i>Total</i>	335	36	60	431

Note: Damage category 1 had the least damage and category 3 had the most. The figures within parentheses represent the percentage of pods in each damage category. Experimental details are given in Section 2.2.

TABLE II. SIZES OF THE VARIOUS CASTES IN FOUR *O. smaragdina* COLONIES AND THE PROPORTION LABELLED AFTER EXPOSURE TO ³⁵S LABELLED MIRIDS

Caste	Number per colony		Percentage labelled	
	Mean	Range	Mean	Range
Large worker	452.0	115-619	59	28-76
Small worker	280.5	123-496	16	12-36
Alate females (queen)	1.25	0-3	100	100
Alate males (king)	10.5	0-22	86	72-100
Larvae	121.25	4-270	68	70-100

Note: Individuals were considered to be labelled when they exceeded 100 counts/min. Experimental details are given in Section 2.3.

because they usually remain within the nest, had presumably become radioactive by coming into contact with the large workers through trophallaxis.

3.3. Behavioural response of mirid nymphs to the presence of *O. smaragdina*

In the presence of *O. smaragdina*, both labelled and unlabelled mirids demonstrated an almost equal propensity to drop from the stem (Table III). In the absence

TABLE III. RESPONSE OF LABELLED AND UNLABELLED FOURTH-FIFTH INSTAR NYMPHS OF *H. theobromae* TO THE PRESENCE OF *O. smaragdina* AS MEASURED BY THEIR TENDENCY TO FALL FROM A BRANCH

Time after release (h)	Ants present		Ants absent	
	Unlabelled mirids	Radiolabelled mirids	Unlabelled mirids	Radiolabelled mirids
4	37 (12)	33 (6)	1 (0)	4 (0)
8	40 (12)	39 (6)	2 (0)	5 (0)
12	40 (12)	40 (6)	3 (0)	10 (0)
16	40 (12)	41 (6)	4 (0)	12 (0)

Note: Each value in the table is the total number of mirids which fell off the branch for three replicates. The figures within parentheses represent the number of injured mirids which fell off. All values are cumulative over time. Experimental details are given in Section 2.3.

TABLE IV. RESPONSE OF UNLABELLED FIRST-SECOND INSTAR NYMPHS OF *H. theobromae* TO THE PRESENCE OF *O. smaragdina*, AS MEASURED BY THEIR TENDENCY TO FALL FROM A BRANCH

Time after release (h)	Ants present	Ants absent
4	17 (0)	0 (0)
8	17 (0)	0 (0)
12	25 (0)	4 (0)
16	27 (0)	10 (0)

Note: Each value in the table is the total number of mirids which fell off the branch for three replicates. The figures within parentheses represent the number of injured mirids which fell off. All values are cumulative over time. Experimental details are given in Section 2.3.

of ants, labelled mirids appeared to show a greater propensity to drop but analysis of the data for the 16th hour shows that the relationship was not statistically significant ($\chi^2 = 3.06$, $df = 1$, $P > 0.05$). When the data for labelled and unlabelled mirids which fell off after 16 h were pooled, the presence or absence of ants was found to have an influence on the propensity of ants to drop ($\chi^2 = 42.2$, $df = 1$, $P < 0.01$).

Considering the case of the injured mirids, inspection of the data in Table III seems to suggest that more of the unlabelled mirids were injured by the ants than were the labelled ones. However, a comparison of the data after 16 h showed that the relationship was not statistically significant ($\chi^2 = 1.39$, $df = 1$, $P > 0.05$).

Table IV summarizes the data for the experiment carried out using first-second instar nymphs. The younger nymphs also showed the same propensity to drop in the presence of the ants as the older nymphs. An analysis of the data for 16 h after release showed the relationship to be significant ($\chi^2 = 6.92$, $df = 1$, $P < 0.01$). However, none of the mirids which dropped showed any signs of injury.

4. DISCUSSION

In the tropics, ants are the most abundant predators present and have great potential as biological control agents. This potential for use in cocoa has been recognized [4-6]. The literature pertaining to predatory ants in the genus *Oecophylla* is extensive [7-9]. The usefulness of *O. smaragdina* in reducing *H. theobromae* damage to cocoa in Malaysia has been suggested [10] and this study confirms it. There are alternative theories accounting for the often observed negative correlation between the presence of the ants and the degree of mirid damage. One such theory is that of different habitat preferences, although for the relationship between *Distantiella theobroma* and *O. longinoda*, Majer [11] favours predatory behaviour by the ant to this theory.

The present study also demonstrated that it is possible to detect predators of the mirids in the field using the radionuclide ^{35}S . However, the presence of levels of radioactivity in the predator higher than background level does not necessarily imply predatory action against the labelled organism: the predator could have scavenged on the bodies of the labelled organism after the latter died. In the case of the relationship between *O. smaragdina* and *H. theobromae*, as discussed below, the inference that there is a predator-prey relationship appears to be reasonable.

Adults of *H. theobromae* are capable of flight when danger is imminent. The present study shows that nymphs are able to respond to a threat by dropping from the substrate. This may provide only temporary respite, because once having dropped to the ground the nymph will not be able to use this mode of escape until it gets off the ground again. Furthermore, a nymph that drops to the ground will have to spend a considerable amount of time getting back onto the tree where its food resources are.

That *O. smaragdina* actively attacks live mirids is indicated by the number of injured mirids that fell off. However, the absence of injured first-second instar nymphs observed among those which fell off cannot be explained and warrants further investigation.

ACKNOWLEDGEMENT

Thanks are due to the Universiti Pertanian Malaysia for financial support for this work and for permission to publish this paper.

REFERENCES

- [1] TAN, G.S., *Helopeltis theivora theobromae* on cocoa in Malaysia. II. Damage and control, Malay. Agric. Res. 3 (1974) 204.
- [2] RITA, M., KHOO, K.C., A technique for rearing the cocoa mirid, *Helopeltis theobromae* Miller, in captivity, Newsl. Malay. Plant Prot. Soc. 7 1 (1983) 8 (Suppl.).
- [3] TEO, H.T., KHOO, K.C., SIPAT, A.B., A radiotracer technique for labelling *Helopeltis theobromae* Miller for the study of its predators in the field, Newsl. Malay. Plant Prot. Soc. 7 1 (1983) 10 (Suppl.).
- [4] SZENT-IVANY, J.J.H., Insect pests of *Theobroma cacao* in the Territory of Papua and New Guinea, Papua New Guinea Agric. J. 13 (1961) 127.
- [5] LESTON, D., Entomology of the cocoa farm, Annu. Rev. Entomol. 15 (1970) 273.
- [6] BAKER, G., "The role of *Anoplolepis longipes* Jerdon (Hymenoptera:Formicidae) in the entomology of cacao in the Northern District of Papua New Guinea", Proc. 14th Int. Congr. on Entomology, Canberra, 1972, p. 327 (abstracts.)
- [7] DUN, G.S., Notes on cacao capsids in New Guinea, Papua New Guinea Agric. Gaz. 8 (1954) 7.
- [8] FERNANDO, H.E., Economic damage and control of cacao capsid, Trop. Agric. Mag. Ceylon Agric. Soc. 112 (1956) 25.
- [9] MARCHART, H., "Radiotracer studies of the predators on *Distantiella theobroma* (Distant) (Hemiptera:Miridae)", Isotopes and Radiation in Entomology (Proc. Int. Symp. Vienna, 1967), IAEA, Vienna (1968) 3.
- [10] AZHAR, I., "Natural and cultural control in the management of selected cocoa pests", Integrated Pest Management in Malaysia (Proc. Sem. Kuala Lumpur, 1984), MAPPS, Kuala Lumpur (1985) 255.
- [11] MAJER, J.D., The influence of ants and ant manipulation on the cocoa farm fauna, J. Appl. Ecol. 13 (1976) 157.

USE OF RADIOISOTOPES TO ELUCIDATE THE ROLE OF REGURGITATION FOR DIRECT TRANSFER OF PARASITES OR DISEASE AGENTS BETWEEN HOST ORGANISMS THROUGH ARTHROPOD VECTORS

W.J. KLOFT, G.H. HESSE*
Institut für Angewandte Zoologie,
Universität Bonn,
Bonn, Federal Republic of Germany

Abstract

USE OF RADIOISOTOPES TO ELUCIDATE THE ROLE OF REGURGITATION FOR DIRECT TRANSFER OF PARASITES OR DISEASE AGENTS BETWEEN HOST ORGANISMS THROUGH ARTHROPOD VECTORS.

In the context of the transmission of parasites and disease agents by bloodfeeding arthropods, the hitherto neglected phenomenon of regurgitation is of the greatest importance. It makes possible the direct transfer of ingested blood, together with these disease agents, within the shortest period of time after intake without the interaction of any circulative or transformative processes in the vector. Owing to such direct transmission from host to host, the epidemiology of vector borne diseases (e.g. arboviruses or certain protozoan diseases such as trypanosomiasis, leishmaniosis or even malaria) is influenced by additional factors. Regurgitative transmission should be considered in programmes of eradication and procedures of quarantine or isolation. We have examined the occurrence of regurgitation in a systematic way with the use of tracer techniques, in combination with other methods. The main arthropods are ticks (especially *Ornithodoros moubata* Murray), bloodsucking Hemiptera (e.g. *Triatoma phyllosoma* Burmeister), bloodsucking Muscidae (mainly *Stomoxys calcitrans* L.) and also mosquitoes. As can be shown with aphid, in which THO was used as a tracer, immediate transmission occurs in stable flies and soft ticks after labelling with ^{32}P and ^{14}C , and it can even be quantified. Also, the output of saliva secreted into and collected from the crop must be regarded as regurgitation rather than salivation. Since it can mix with previously ingested food (blood plus disease agents), this type of regurgitation can also contribute to the transmission of diseases by arthropods.

1. INTRODUCTION

In several papers [1-3], we showed radioisotopes to be model substances which can be used to demonstrate the mode of pathogen transmission by arthropod vectors to animals and plants. We discussed four ways of transmission: (a) via external contamination of the parts of the mouth, (b) via secretion with saliva; (c) via defecation after passage through the alimentary tract; (d) via regurgitation. The last aspect is one of the more neglected methods of transmission in phytopathology, though in medical

* Present address: Bayer AG, VT-V/GF-HYG, Zentrum Landwirtschaft Monheim Bayerwerk, D-5090 Leverkusen, Federal Republic of Germany.

parasitology it has great importance in the transmission of plague by fleas and leishmaniosis by phlebotomid flies. It is necessary first to give a clear definition of regurgitation and classify its different types. Regurgitation is the functional reflux of gut content, either out of the crop or the midgut itself. This reaction occurs under various conditions and therefore has different functions, which can be classified as follows:

- (1) Regurgitation as normal behaviour:
 - (a) As part of the feeding characteristics
 - (b) As trophallaxis
 - (c) As regurgitative type feeding at immature stages of growth.
- (2) Regurgitation under exceptional conditions:
 - (a) As a defence behaviour
 - (b) For flushing the blocked food channel
 - (c) As emesis
 - (d) As a reaction to 'mechanical' stress.
- (3) Regurgitation owing to hitherto unknown factors.

The regurgitative reaction includes physiological, morphological, functional and behavioural aspects and thus the classification of Hesse [4] is somewhat incomplete. For this reason, we provide some complementary explanations to the above list.

- (1a) External and extra-intestinal digestion play a major role in certain insect groups, especially in predacious species, where the enzymes are bound by saliva or are regurgitated even from very distant parts of the midgut (for special structures in Myrmeolonidae, see the reference to Buschinger and Bongers in Kloft and Bungard [5]) and lead to predigestion. Regurgitative food uptake is also known to occur in certain muscid flies, which regurgitate the contents of the crop for carbohydrate predigestion.
- (1b) Trophallaxis, as a mutual exchange of food in 'social' insects, has, in this context, no importance for our discussion in spite of the fact that certain microbial or fungus diseases within colonies of social insects can be spread this way.
- (1c) In contrast to (1b), this is a one-way system because only at immature stages are insects fed with regurgitated materials by adults.
- (2a) The defence behaviour of many arthropods includes reflex-like regurgitation, with the defence effect coming from the regurgitated fluid only.
- (2b) Flushing of the blocked food channel is one of the major models explaining regurgitation in those arthropods which take up such fluids as plant sap or blood. Those with piercing-sucking mouth parts have different channels for blood and saliva and particles of food can sometimes block the tips or posterior parts of the buccal channel. In such cases, regurgitation in brief bursts can propel the blocking particles away from the sheath opening or out of the channel.

- (2c) Emesis is defined as a reaction to prevent intoxication of the feeding arthropod after peroral uptake of certain substances. For example, there are emetic reactions of predators feeding on toxic prey, emetic regurgitation after peroral uptake of arsenic insecticides, etc.
- (2d) Regurgitation as a reaction to mechanical stress can compensate for increased internal or external pressures. The same is possible, of course, by the discharge of rectal contents.

What is the reason for using radioisotopes to demonstrate regurgitation and what are the advantages provided by the tracer method in such a type of research? As we have shown [1-3], the use of radioisotopes makes it possible to discriminate between the four methods of transmission mentioned above by quantification and, especially, by consideration of the time factor. It is easy just by registering the number of counts per minute (counts/min) to differentiate between transmission of externally contaminated material (low counts/min) and a sudden expulsion (large count rates). The secretion of material previously taken up perorally with the saliva requires a series of physiological processes, such as reabsorption in the midgut, transport via the haemolymph, transfer of haemolymph salivary gland epithelium, secretion from the gland cells into the gland reservoir and resecretion with saliva into another host's tissue. Since these processes are time consuming — according to our results with biting flies [2], they took between 2 h (for hornflies) and 6-8 h (for *Stomoxys calcitrans* L., *Musca domestica* L. and *Lucilia cuprina* Wiedemann) — we can use the factor of time in order to differentiate between salivary secretion and regurgitation. All of these physiological processes, from gut absorption to resecretion, are temperature dependent for their speed of occurrence [5].

The spreading of dangerous virus diseases and the recent discussion of the role of haematophagous insects [6] are the main reasons. Discussion of the problem from the point of view of radiotracer techniques is necessary.

2. REGURGITATIVE TRANSFER OF DISEASE AGENTS OR PARASITES THROUGH HAEMATOPHAGOUS ARTHROPODS

A series of synanthropous, non-bloodfeeding Diptera, mainly belonging to the Muscidae family, are very important as vectors of different parasites and pathogenic microorganisms. The transmission occurs by external contamination as well as by regurgitation of crop contents [7-9]. In our context, however, we are mainly interested in regurgitation by haematophagous Diptera. Since these insects are either capillary or pool feeders [10], they would be able, in the case of regurgitation of parts of a previously intaken blood meal, to inject this, together with pathogens, directly into the bloodstream of the next host. We have followed this line of investigation

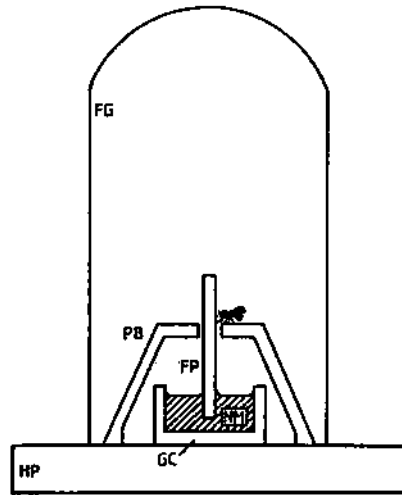

FIG. 1. Arrangement for feeding *S. calcitrans* L. The flies are enclosed in a flying glass (FG) in which they can move freely. However, they cannot get access to the labelled nourishing medium (NM) — in this case defibrinated human blood labelled with ^{32}P — which is in a glass container (GC), since this is covered with a plastic beaker (PB). The beaker has a slit through which a strip of filter paper (FP) is inserted into the medium, with the paper soaking up the medium. The arrangement is placed on a heating plate (HP), so that the blood is kept at 37°C .

since 1976 [1–3] and found the phenomenon of regurgitation, especially in experiments with the stable fly, *Stomoxys calcitrans* L. We also obtained the first results in experiments with radiolabelled (^{32}P) blood. The defibrinated radioactive blood was offered to the flies in capillary tubes out of which the flies began sucking after insertion of their proboscis. We prevented external contamination by suspending the flies by their wings and by keeping their legs glued together. After food uptake, the flies were able to probe on semiliquid sucrose-agar. (The agar was cooked either in a sucrose solution or in serum and pressed out of a thin rubber or plastic tube attached to a syringe filled with water. The water pressure is used to expel (squeeze out) the agar in the shape of a column. Phagostimulants, as listed by Galun [11, 12], can also be added to the agar.) The insertion of the proboscis into the agar led to external decontamination. This was checked by measuring the parts of the columns on which the stable flies were probing. Since, in several cases, we found very high radioactivity, from one-thirtieth up to one-tenth of the total radioactivity (in counts/min) taken in with the blood meal (total activity can be measured by whole body counts after careful decontamination), we argued that the only possible explanation for this was regurgitation. This was the beginning of systematic experimental research by Hesse [4].

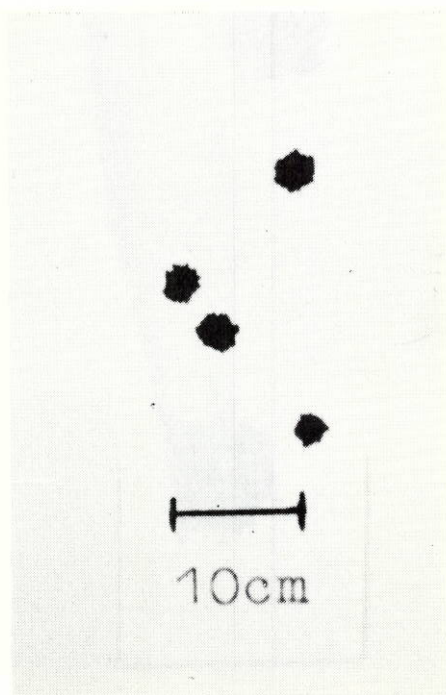

FIG. 2. Red spots, indicating regurgitation of blood by engorged *S. calcitrans* while probing on filter paper soaked in 20% sucrose.

It was possible for the flies to feed on defibrinated blood, as shown in Fig. 1. Using radiolabelled blood and calculating the relation between the counts/min (after whole body counts) and volume, we found that the flies feed, on average, for a period of 2.6 min and take in 8.2 μL of blood up to the completion of feeding.

2.1. Demonstration of regurgitation in *S. calcitrans* L.

Proof of regurgitation can be provided using various methods. Owing to our previous results with radiotracers, we even tried optical methods. Adult stable flies of both sexes were fed, as described in Fig. 1, with citrated, heated (37°C) human blood. Either after 1 min or after feeding was completed (on average after 2.6 min), the flies were transferred to a second feeding arrangement, of the same type as shown in Fig. 1. They were able to feed on filter paper soaked in a 20% sucrose solution. Regurgitation could be seen as red spots on the filter paper (Fig. 2). After only 1 min of blood feeding, four of the transferred 20 flies regurgitated. The size of the spots corresponded to a volume of c. 1 μL . The red spots could be seen with the naked eye.

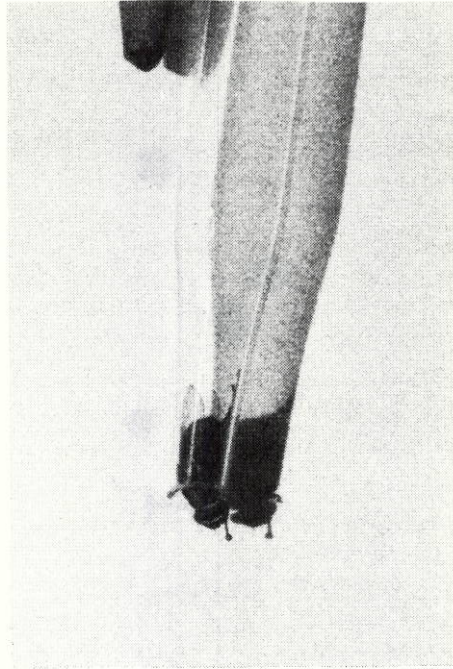

FIG. 3. *Stomoxys calcitrans*, enclosed in the tip of a glass pipette. As described in the text, the fly can only put its head with proboscis through the opening and thus feed on an offered source without the legs or wings getting contaminated. On the tip of the proboscis a droplet of regurgitated blood can be seen.

Using radiotracers as a label, the flies were manipulated to the tip of a glass pipette. The pipette had an opening through which the flies could only put their head with proboscis, but not their legs and wings. Thus no contamination — except of the proboscis — could occur. We used the described sucrose-agar columns for probing by the insects, for decontamination and for collection (and subsequent measuring of the activity) of regurgitated blood. In a series of cases, we observed regurgitation of blood droplets (Fig. 3), which were also collected with a Hamilton-Microliter syringe. As pointed out in Tables I and II, we were able to differentiate between normal conditions and stress situations. As a stress factor, we induced a very slight degree of pressure, caused by inserting a small piece of cotton wool into the wider end of the pipette. Thus, while we did not have a real mechanical pressure on the abdomen, we did introduce a stress situation in which the flies could not move forward or backward. After only 1 min of feeding time, 10 out of 15 flies had regurgitated. Out of an average of 3.1 μL of blood meal ingested, 0.075 μL was regurgitated under normal conditions and 0.09 μL under stress conditions. After the feeding, we found that regurgitation occurred under normal conditions in 40% of the flies and under stress conditions in 80%. The amount of regurgitated blood ranged from

TABLE I. DEMONSTRATION OF REGURGITATION IN *S. calcitrans* L. USING ^{32}P AS A RADIOTRACER. THROUGH MEASUREMENT OF DIFFERENT VOLUMES OF LABELLED BLOOD, A RELATIONSHIP BETWEEN COUNTS/MIN AND VOLUME (μL IN THE TABLE) CAN BE CALCULATED (Feeding time is 1 min)

Total volume of blood taken in (μL)	Amount contaminating the mouth parts (μL)	Regurgitated volume (μL)	
		Undisturbed	Under stress conditions (narrow space, slight pressure)
4.1	0.09	—	0.12
3.2	0.04	0.06	0.04
2.3	0.07	—	0.12
5.1	0.04	0.09	—
2.3	0.03	—	0.08
2.5	0.07	—	—
3.4	0.04	—	—
2.1	0.03	—	0.11
4.3	0.05	—	0.08
3.7	0.05	—	0.14
2.5	0.04	—	—
2.8	0.06	—	—
3.4	0.05	—	0.09
2.7	0.06	—	—
3.1	0.05	—	0.04

0.10–0.18 μL . Since the counts/min in regurgitation are significantly higher than after external decontamination, the differences between the two phenomena in most cases caused no problems.

2.2. Regurgitation in a haematophagous Rhynchota

In vivo regurgitation has been described by Lavoipierre et al. [13] for *Rhodnius prolixus* Stal., *Triatoma infestans* Klug and *T. protracta* Klug. Smith and Friend [14] and Friend and Smith [15] used artificial diets in their in vitro experiments to which frog erythrocytes had been added as markers. Simultaneously, they recorded the regurgitations electrically and also observed the flushing back of big frog erythrocytes.

TABLE II. DEMONSTRATION OF REGURGITATION IN *S. calcitrans* L. USING ^{32}P AS A RADIOTRACER. THROUGH MEASUREMENT OF DIFFERENT VOLUMES OF LABELLED BLOOD, A RELATIONSHIP BETWEEN COUNTS/MIN AND VOLUME (μL IN THE TABLE) CAN BE CALCULATED

(Feeding time is up to completion of meal, which on average is 2.6 min)

Total volume of blood taken in (μL)	Amount contaminating the mouth parts (μL)	Regurgitated volume (μL)	
		Undisturbed	Under stress conditions (narrow space, slight pressure)
9.5	0.03	—	0.18
9.3	0.02	0.07	0.09
8.5	0.02	0.05	—
7.5	0.04	—	0.11
13.0	0.03	—	0.09
8.3	0.04	0.08	0.04
5.3	0.03	0.06	0.05
6.4	0.06	0.01	0.11
7.9	0.04	—	—
6.8	0.03	—	0.17
6.3	0.03	0.14	—
9.0	0.03	—	0.12
9.3	0.02	—	0.07
7.5	0.04	—	0.16
8.9	0.03	—	—

Since there normally does not seem to be a need for flushing of a blocked food channel, because the saliva with its anticoagulant activity soaks back, the authors felt that the regurgitation which occurred was possibly a "misfiring", a reverse in the direction of flow in the oesophagus. We used L_v of *Triatoma phyllosoma* Burm. for our experiments and offered artificial diets through a Parafilm membrane. Adenosinetriphosphate (ATP) was added as a phagostimulant. Using ^{32}P as a label, we observed regurgitation as early as 5 min after feeding after transfer to an unmarked diet. After longer feeding times, up to 53% of the insects regurgitated amounts between 1.01 and 7.4 μL , though in nearly all of these cases (except for one *T. phyllosoma*) the regurgitation occurred only under stress conditions. It is important

to note that, according to published measurements [14], only a volume of 0.05 μL can be calculated for the feeding channel within the stylets. Therefore, the much higher volumes in our experiments clearly indicate regurgitation. In experiments with defibrinated blood, we only obtained regurgitation of serum (as shown by the Ouchterlony assay for serum). However, there were no red erythrocytes. Whether there exists a filter mechanism is currently unknown. Labelled saliva can always be excluded because of the time factor mentioned above.

2.3. Evidence of regurgitation by the tick, *Ornithodoros moubata* (Ixodoidea: Argasidae), using a radioactive tracer

Regurgitation as a functional reflux of midgut content is described for certain ticks and is discussed in relation to the possibilities for the transfer of pathogens and toxins. To clarify the question of regurgitation in *Ornithodoros moubata* Murray, the feeding solutions were labelled with the isotope ^{32}P . The reaction could be shown to be part of the normal feeding behaviour and as a stress reaction after slight pressing of the idiosoma. After feeding bovine blood, female ticks showed a high rate of normal regurgitation (63.6%). After feeding of an artificial diet, no normal reflux occurred, though it did occur after slight pressing. After 20 min (blood) and 25 min (diet) of feeding time, the first regurgitation occurred. The high rate of normal regurgitation after the blood meal has the function of rinsing out the blocked food channel. Pool feeders ingest large portions of broken down tissue mixed with blood that, together with an extended feeding time and a lack of haemolysis in the pool, can result in the build up of a plug in the narrow food channel. Functional reflux of haemolysed midgut content and salivation removes the plug. Tagged saliva cannot be the source of radioactivity because the isotope needs a longer time to be incorporated into the salivary glands. We refer to the short publication of Hesse [16] and, in particular, to Ref. [4].

3. REGURGITATION IN PLANT FEEDING HOMOPTERA AS A POSSIBLE MECHANISM FOR TRANSMISSION OF VIRUS DISEASES

Harris and Bath are believed to have been the first to observe regurgitation by the aphid *Myzus persicae* during membrane feeding and to have discussed its likely function in the transmission of non-persistent plant viruses [17]. As Pirone and Harris [18] pointed out, the phytopathogenous virus can be classified, according to the time it remains in the vector, on the basis of the following types: non-persistent (only for a short time: minutes or hours); persistent (for a long time: weeks or months); semipersistent (times in between). Another classification can be made according to the place where the virus is found in the vector. We differentiate between 'stylet-borne' (where the virus has contaminated only the piercing-sucking mouth parts) and 'non-circulative' (where the virus has no latency in the vector, does

not circulate and cannot be transmitted any more after moulting). The most dangerous type is a 'circulative' virus, which circulates and can multiply in the vector, is distributed within the haemolymph, enters the salivary glands and is transmitted with the saliva. As already pointed out [2], Kloft [19] verified the observation of Harris and Bath [17]. The aphid *Aulacorthum circumflexum* (Buckt.) was fed on *Vicia faba* sprouts standing in a nutrient solution containing THO (specific activity 0.2 mCi/mL).¹ The aphids were removed from the labelled plant, were allowed to 'clean' their stylets by probing on non-radioactive plants and were immediately transferred to leaf discs where they probed for 0.5–15 min. The leaf discs were burned in a Packard Autooxidizer, Model No. 504. We found that during probing times of from 1 to 3 min, a relatively large amount of ³H was transferred — the only explanation is regurgitation. On the basis of these results, Harris published an ingestion-egestion hypothesis of non-circulative virus transmission [20]. Egestion means regurgitation; in fact, alate aphids are considered by us to be 'flying virus syringes'. In Indonesia, the green rice leafhopper, *Nephotettix cinctipes* (Homoptera:Cicadellidae) is a vector of six virus diseases. Besides transfer from contaminated mouth parts or with saliva, there is also regurgitative transmission to be taken into consideration. We studied (in 1987) regurgitation as a possible mode of transmission of virus by the green rice leafhopper using tracer techniques [21]. The hoppers were fed through Parafilm sachets containing 10% sucrose solution and labelled with ³²P as a phosphate; the activity was about 4000 (dis/min)/μL. For stylet decontamination, the leafhoppers could either probe in sucrose-agar (filled in a glass tube which was covered with stretched Parafilm) or on rice seedlings.

In 10% of the experiments we obtained evidence of higher activities which are significantly different from decontamination. However, this happened only after short feeding times of between 15 and 30 min — the leafhoppers regurgitated only after interruption of the feeding followed by immediate transfer to a new feeding site. In our experiments we found the duration of one feeding act to be in the range of 1 h or more. Our conclusion, therefore, in the case of *Nephotettix*, is that if there is a disturbance the mechanism of regurgitation can be induced. This process may shorten the time of transmission for non-circulative virus diseases.

4. DISCUSSION

As pointed out in the Introduction, radiotracer techniques have been used to highlight the phenomenon of regurgitation. So far, we have included in this type of research ectoparasitic arthropods as haematophagous insects of different orders (Rhynchota, Diptera) and ticks for purposes of comparison with earlier results on plant virus transmitting Homoptera. The question of the possible transmission of the

¹ 1 curie (Ci) = 3.70×10^{10} Bq.

dangerous human immuno-deficiency virus (HIV) by haematophagous insects is discussed in the literature. However, the authors feel that the quantities of externally adhering blood might be too small for transmission of infectious material. Also, calculations on the content of blood remaining in the anterior part of the oesophagus (haematophagous insects) and in the food channel of the stylets (plant sucking Rhynchota) seem to support these considerations. Thus, we know exactly from aphids (*Aphis* sp.) the volume of the food channel in the stylets: from the tip of the stylet up to the pharyngeal sensory organ there is volume of only 0.2 pL (0.2×10^{-12} L) [22]. For haematophagous insects or ticks we do not have exact measurements. However, the diameter of the food channel (for Rhynchota) or oesophagus (for Diptera, Nematocera and Muscidae) must be wide enough for the passage of erythrocytes (7.5 μm for human blood). The same is the case for all other types of bloodfeeding insects or ticks. However, in all published material so far, the phenomenon of regurgitation of the gut contents, which requires relatively large volumes, of the order of magnitude of 1 μL , has not been taken into consideration. Seen from this point of view, the role of bloodfeeding arthropods must receive new attention for their ability to transmit disease agents of various kinds. It is unimportant whether regurgitation occurs as normal behaviour or only under stress conditions (stable flies, tsetse flies, soft ticks) — we know that biting insects or ticks are frequently opposed to the stress of defensive movements by the host.

Radioisotopes have served in our experiments as model substances for disease agents. For conclusive evidence and experiments we should use the transmission of infectious material. Work is in progress on transmission of *Borrelia*, in co-operation with the Institute of Medical Parasitology, Bonn (W. Maier and M. Seitz). We are even trying to facilitate the regurgitative transmission of *Plasmodium* by *Anopheles*. In one single case (out of 200 experiments), transmission of malaria from a mouse was successful. The mosquito feeding on a mouse with high parasitaemia was interrupted while feeding and quickly transferred to a baby mouse (see Ref. [23]). We do not know yet about the factors which are triggers for regurgitation in the different groups. We must also take into consideration differences between the different strains of arthropods. We regularly induced regurgitation in laboratory strains of *S. calcitrans* in Gainesville, Florida, as well as in Bonn (flies provided by the Bayer Company). However, in 1987, we could not demonstrate regurgitation in stable flies during our regional radioisotope training course in Nairobi, Kenya. The stable flies which we could obtain have been caught in the field and are of unknown age. Thus we are really at the very beginning of an important field for future research. For the epidemiology of certain diseases of which the pathogenic agent (virus, bacteria, protozoans) is transmitted by haematophagous arthropods, direct regurgitative transmission without obligatory developmental circulation in the vector could be of importance.

ACKNOWLEDGEMENTS

The authors wish to express their thanks to W. Maier and H.M. Seitz, from the Institute of Medical Parasitology, University of Bonn, for their generous co-operation.

REFERENCES

- [1] KLOFT, W.J., BUTLER, J.F., KLOFT, E.S., Radioaktive Isotope als Modellsubstanzen zur Klärung des Übertragungsmodus von Pathogenen durch Insekten bei Pflanze und Tier, Z. Angew. Entomol. 82 1 (1976) 64.
- [2] KLOFT, W.J., CROMROY, H.L., KLOFT, E.S., "Use of isotopes as model substances to elucidate the mode of transmission of pathogens to animals and plants by arthropod vectors", Isotope and Radiation Research on Animal Diseases and Their Vectors (Proc. Int. Symp. Vienna, 1979), IAEA, Vienna (1980) 299.
- [3] BUTLER, J.F., KLOFT, W.J., DuBOSE, L.A., KLOFT, E.S., Recontamination of food after feeding of ³²P food sources to biting Muscidae, J. Med. Entomol. 13 4 (1977) 567.
- [4] HESSE, G.H., Die Regurgitation bei Arthropoden, und ihre Bedeutung im Zusammenhang mit der Übertragung von Krankheitserregern, Diplomarbeit, University of Bonn (1981).
- [5] KLOFT, W.J., BUNGARD, K., Erfassung der Resekretion von peroral aufgenommenem Radiophosphat mit dem Speichel bei Fliegen, Z. Angew. Zool. 62 (1975) 83.
- [6] BOOTH, W., AIDS and insects, Science 237 (1987) 355.
- [7] EMMEL, L., Die Rolle der Fliegen als Krankheitsüberträger: Untersuchungen zur Frage der Bedeutung von Musca domestica bei der Übertragung der Bakterienruhr, Z. Hygiene 129 (1949) 288.
- [8] KUEHLHORN, F., Über Substratkontakte und Raumbeziehungen einiger heimischer Dipterenarten von medizinisch-hygienischer Bedeutung. Z. Angew. Zool. 3 (1968) 257.
- [9] LECLERCQ, M., Entomological Parasitology — The Relations between Entomology and Medical Sciences, Vol. 29, Pergamon Press, Oxford (1969).
- [10] EHRHARDT, P., Einfluss von Ernährungsfaktoren auf die Entwicklung von Säfte-saugenden Insekten unter besonderer Berücksichtigung von Symbionten, Z. Parasitenk. 31 (1968) 38.
- [11] GALUN, R., "Recent developments in the biochemistry and feeding behaviour of haematophagous arthropods as applied to their mass rearing", Sterility Principle for Insect Control or Eradication (Proc. Int. Symp. Athens, 1970), IAEA, Vienna (1971) 273-282.
- [12] GALUN, R., "The physiology of haematophagous insect-animal host relationships", Proc. 15th Int. Congr. on Entomology, Washington, DC, 1976, (WHITE, D., Ed.), Entomological Society of America, College Park, MD (1976) 257.
- [13] LAVOPIERRE, M.M.J., DICKERSON, G., GORDON, R.M., Studies on the methods of feeding of blood-sucking arthropods — I. The manner in which Triatomine bugs obtain their blood meal, as observed in the tissues of the living rodent, with some remarks on the effects of the bite on human volunteers, Ann. Trop. Med. Parasitol. 53 (1959) 235.
- [14] SMITH, J.J.B., FRIEND, W.G., Feeding in *Rhodnius probixus*: Responses to artificial diets as revealed by changes in electrical resistance, J. Insect. Physiol. 16 (1970) 1709.
- [15] FRIEND, W.G., SMITH, J.J.B., Feeding in *Rhodnius probixus*: Mouthpart activity and salivation, and their correlation with changes of electrical resistance, J. Insect. Physiol. 17 (1971) 233.
- [16] HESSE, G., Evidence of regurgitation by *Ornithodoros moubata* (Ixodea: Argasidae) using a radioactive tracer, Zentralbl. Bakteriol. Hyg. A256 (1983) 267.

- [17] HARRIS, K.F., BATH, J.E., Regurgitation by *Myzus persicae* during membrane feeding: Its likely function in transmission of nonpersistent plant viruses Ann. Entomol. Soc. Am. 66 4 (1973) 793.
- [18] PIRONE, P., HARRIS, K.F., Nonpersistent transmission of plant viruses by aphids, Annu. Rev. Phytopathol. 15 (1977) 55.
- [19] KLOFT, W.J., "Radioisotopes in virus research", Aphids as Virus Vectors (HARRIS, K.F., MARAMOROSCH, K., Eds.), Academic Press, New York (1977) 291.
- [20] HARRIS, K.F., "An ingestion-egestion hypothesis of noncirculative virus transmission", *ibid.*, p.165.
- [21] KUSWADI, A.N., KLOFT, W.J., in preparation.
- [22] SCHNORBACH, H.J., Der Einfluss von Besiedlungs- und Einstechverhalten auf Beginn und Verlauf der Nahrungsaufnahme bei Blattlausgruppen an Wirtspflanze und künstlicher Diät, Phd thesis, University of Bonn (1982).
- [23] CHUTMONGKONKUL, M., Phd thesis, University of Bonn, in preparation.

UTILISATION DE L'IRIDIUM 191 ET DE L'AZOTE 15 POUR LE MARQUAGE D'INSECTES DU COLZA D'HIVER

Y. BALLANGER

Centre technique interprofessionnel des oléagineux
métropolitains (CETIOM),
Montgiscard

L.A. BUSCARLET

Département de biologie,
CEA, Centre d'études nucléaires de Cadarache,
Saint-Paul-lez-Durance

France

Abstract-Résumé

USE OF IRIIDIUM-191 AND NITROGEN-15 TO LABEL WINTER COLZA INSECTS.

In preparation for an investigation of winter colza insect population dynamics for the flea beetle (*Psylliodes chrysocephala* L.) and the stem weevil (*Ceuthorrhynchus napi* Gyll.), a study was made of the possibility of using as labels iridium-191 analysed by gamma spectrometry after activation in a reactor, and nitrogen-15 measured by means of optical spectrometry. The insects are fed on colza leaves previously soaked in a solution of iridium (H_2IrCl_6) and/or nitrogen-15 ($(NH_4)_2SO_4$). The iridium has the advantage of remaining in the body of the animal for a long time and enables large populations to be screened. In the stem weevil, the label remains fairly stable with time, but in the flea beetle it is weaker and less persistent. Nitrogen-15 is not as advantageous as iridium because its detection involves, of necessity, the preparation of each insect tested. It should only be used for subjects already labelled with iridium. In the release and recapture experiments for which these tests were intended, the main aim was to explain the disparities in infestation levels often observed from one field to another, and to draw lessons from them as regards crop supervision recommendations. Checks performed on the reared animals sampled after release indicate that, in three cases out of four, the freed insects were satisfactorily labelled.

UTILISATION DE L'IRIDIUM 191 ET DE L'AZOTE 15 POUR LE MARQUAGE D'INSECTES DU COLZA D'HIVER.

Afin de préparer une étude de dynamique de populations d'insectes du colza d'hiver, l'altise d'hiver (*Psylliodes chrysocephala* L.) et le charançon de la tige (*Ceuthorrhynchus napi* Gyll.), on a étudié les possibilités de marquage de l'iridium 191, analysé par spectrométrie gamma après activation dans un réacteur, et de l'azote 15, mesuré par spectrométrie optique. Les insectes sont nourris à partir de feuilles de colza, préalablement trempées dans une solution d'iridium (H_2IrCl_6) et (ou) d'azote 15 ($(NH_4)_2SO_4$). L'iridium présente l'intérêt de résider longtemps dans le corps de l'animal. Il permet de réaliser les mesures de détection sur des effectifs importants. Pour le charançon, le marquage est assez stable dans le temps; pour l'altise, il est plus faible et moins persistant. L'azote 15 ne présente pas le même intérêt que l'iridium car sa détection nécessite la préparation de chaque insecte testé. On ne doit l'utiliser que chez des individus déjà marqués à l'iridium. Dans les expériences de lâchers-recaptures pour lesquelles ces essais étaient destinés, il s'agissait en particulier d'expliquer les disparités de niveaux

d'invasion souvent constatées d'un champ à l'autre et d'en tirer des enseignements sur les recommandations en matière de surveillance des cultures. Les vérifications faites sur les animaux d'élevage échantillonnés à partir des lâchers permettent de supposer que, dans trois cas sur quatre, les insectes libérés étaient marqués de façon satisfaisante.

1. INTRODUCTION

Des possibilités de marquage d'insectes du colza d'hiver, l'altise d'hiver (*Psylliodes chrysocephala* L.) et le charançon de la tige (*Ceuthorrhynchus napi* Gyll.), sont étudiées afin de préparer des expériences de «lâchers-recaptures» s'intégrant dans une étude de dynamique de populations conduite à Saint-Thomas-en-Royans (Drôme) de 1981 à 1985 [1, 2].

De telles expériences ont déjà été réalisées avec d'autres insectes du colza d'hiver, en Tchécoslovaquie [3], en République démocratique allemande [4] et en Suède [5], à l'aide de marquages avec des éléments radioactifs. Pour des raisons de protection de l'environnement, ces techniques sont désormais difficilement envisageables en France.

Nous nous sommes intéressés aux possibilités de marquage offertes par certains éléments chimiques rares tels que l'iridium, décelable après radioactivation isotopique [6, 7], et l'azote 15 reconnaissable d'après la mesure des enrichissements isotopiques [8].

2. MATERIELS ET METHODES

Les techniques s'appliquent aux adultes, stades qui assurent la dissémination des insectes étudiés. Les essais ont été réalisés en 1983 et 1984 avec l'altise, en 1984 et 1985 avec le charançon. Ils ont été effectués en simple ou en double marquage.

2.1. Elevage

On ne dispose pas d'élevages permanents. Les animaux sont prélevés dans des cultures de colza d'hiver.

Les altises sont marquées en juin, peu avant les récoltes des cultures. Au terme de la nymphose, les adultes émergent et s'alimentent pour constituer des réserves. Ils subissent ensuite un arrêt de développement estival qui leur permet de survivre jusqu'en septembre, période à laquelle ils reprennent leur activité et cherchent à investir les cultures à la levée.

Les charançons sont marqués en mars, après la diapause estivo-hivernale, au moment des vols qui leur permettent de passer des anciens colzas (cultures de l'année précédente) aux colzas en place (cultures de l'année).

Les altises sont récupérées au filet-fauchaie. Les charançons sont capturés à l'aide de cuvettes jaunes.

2.2. Marquage

Les insectes sont nourris à partir de feuilles de colza, préalablement trempées dans une solution saline d'élément(s) marqueur(s) puis séchées à l'air. On utilise l'iridium sous forme de chlorure (H_2IrCl_6) en solution, à 2,4 g/L, et l'azote 15 sous forme de sulfate ($(\text{NH}_4)_2\text{SO}_4$), à 10 g/L.

Les altises sont marquées dans les conditions ambiantes du laboratoire (18–22°C), transférées à l'extérieur à partir du moment où la cessation d'activité est manifeste, puis ramenées à l'intérieur.

Les charançons sont maintenus à l'extérieur pour le marquage dans un endroit abrité, et ramenés à l'intérieur pour les élevages. Dans les expériences de lâcher-recapture décrites ailleurs [9], les insectes ont été libérés après les quelques jours de captivité nécessaires au marquage.

L'iridium 191 stable est activable en iridium 192 radioactif. Pour cette opération, réalisée au Centre d'études nucléaires de Grenoble dans le réacteur Mélusine (flux de $1,4 \times 10^{13}$ neutrons/cm²·s), les insectes sont conditionnés dans des gélules. La radioactivité de l'élément activé étant fonction de la durée de radioactivation, on a progressivement augmenté la durée des activations de 60 à 90 et enfin à 120 min pour rendre la détection plus facile.

L'iridium 192 a une période de décroissance radioactive relativement longue (74,2 d) qui permet une bonne souplesse d'analyse. Le marquage est jugé effectif lorsque le spectre caractéristique de l'iridium 192 est obtenu sur l'écran cathodique d'un spectromètre gamma (DIDAC 800, Intertechnique). On peut alors noter, par exemple, la hauteur du plus important pic du spectre obtenu.

L'azote 15 est révélé par analyse de l'émission lumineuse de l'azote gazeux dans un champ de hautes fréquences, au moyen d'un spectromètre optique. On mesure un excès isotopique par référence à la mesure d'échantillons non marqués. La préparation des échantillons gazeux consiste à minéraliser un fragment de chaque insecte testé (ici, un demi-élytre) préalablement placé dans une ampoule scellée sous vide.

3. RESULTATS

Cette étude consiste à tester le marquage d'animaux maintenus en élevage sur des fragments frais de colza d'hiver pendant un temps plus ou moins long, après ingestion d'une première alimentation marquée, ou non, par les éléments marqueurs.

3.1. Marquage des insectes à l'iridium

Les analyses sont effectuées environ un mois après le passage dans le réacteur. L'échelle de sensibilité minimale de l'analyseur multicanaux Didac est la plus utilisée ($\times 0.2$). On considère qu'un échantillon est faiblement marqué si la hauteur du pic le

TABLEAU I. TESTS DE MARQUAGE A L'IRIDIUM (4 JOURS DE MARQUAGE) DE L'ALTISE D'HIVER REALISES EN 1983

1983	Insectes					Males ^x					Femelles ^x				
	0	+	*	**	Tot.	0	+	*	**	Tot.	0	+	*	**	Tot.
S31	1	7	95	87	190	-	1	46	18	65	-	5	31	54	90
S32	-	4	3	70	77	-	3	-	37	40	-	1	3	33	37
S33	3	4	58	-	65										
S34	4	11	8	-	23	-	3	5	-	8	4	4	2	-	10

^x: distinction partielle des sexes

0: non marqué (ou traces)

+: marqué (limite inférieure de détection)

*: bien marqué (échelle de sensibilité maximale du détecteur)

** : très marqué (autres échelles de sensibilité)

Tot.: Total

S31: insectes sacrifiés après 3 jours d'alimentation

S32: insectes alimentés à volonté, morts pendant l'estivation

S33: insectes alimentés à volonté, morts après reprise d'activité et 10 jours d'alimentation

S34: insectes alimentés à volonté, morts après reprise d'activité et 16 jours d'alimentation

plus important du spectre de l'iridium n'est pas supérieure à une subdivision de l'écran. Compte tenu des modifications de procédures (temps d'irradiation, temps de lecture, délais d'analyses, etc.), les comparaisons de valeurs ne sont pas toujours possibles.

3.1.1. Altise d'hiver

L'élevage des animaux actifs ne présente pas de difficultés. Le maintien des insectes en estivation (marqués ou non) est au contraire problématique: on observe des taux de mortalité avoisinant 90% en 1983 ainsi qu'en 1984 malgré des soins plus attentifs.

Les résultats de la campagne 1983 sont consignés dans le tableau I: parmi les insectes examinés peu de temps (3 jours) après le marquage (S31), un seul n'est pas marqué sur 190 et 7 sont marqués faiblement. Les insectes morts pendant l'estivation (S32) sont tous marqués. Par contre, 10 et 16 jours après la reprise d'activité (S33, S34), la proportion de non marqués est respectivement de 3/65 et 4/23.

En 1984 (tableau II), après 3 jours de marquage et 2 jours d'alimentation sans marqueur, on observe 4 insectes non marqués sur 60. La proportion d'insectes morts pendant l'estivation (S42) et non marqués atteint 20%, celle des insectes faiblement marqués 25%. Chez les insectes élevés jusqu'à leur mort naturelle (S43), le dernier étant sacrifié le 1/2/1985, la proportion de non marqués atteint 30%.

TABLEAU II. TESTS DE MARQUAGE A L'IRIDIUM (3 JOURS DE MARQUAGE) DE L'ALTISE D'HIVER REALISES EN 1984
(Symboles comme sur le tableau I)

1984	0	+	*	**	Total
S41	4	4	12	40	60
S42	12	15	12	20	59
S43	8	7	10	1	26

S41: insectes sacrifiés après 2 jours d'alimentation

S42: insectes alimentés à volonté, morts pendant l'estivation

S43: insectes alimentés à volonté, morts après reprise d'activité

TABLEAU III. TESTS DE MARQUAGE A L'IRIDIUM (2 JOURS DE MARQUAGE) DU CHARANÇON DE LA TIGE REALISES EN 1984
(Symboles comme sur le tableau I)

1984	0	+	* **
Lot 1 (+0 jours)	-	1	19
Lot 1 (+8 jours)	-	6	14
Lot 2 (+8 jours)	-	1	19

TABLEAU IV. TESTS DE MARQUAGE A L'IRIDIUM DU CHARANÇON DE LA TIGE REALISES EN 1984: SURVIE DES INSECTES EN ELEVAGE

Lots	Marquage	Charançons	11/02	Pertes cumulées			3/04	Sacrifiés 3/04
				8/03	22/03	3/04		
2 et 5	oui	33+44 = 77	9	17	47	66	11	
3 et 4	non	42+46 = 88	5	19	55	78	10	
		8	8	22	62	87	13	

Mise en élevage : le 6/02 (lots 2 et 3) ou le 8/02 (lots 4 et 5)
marquage sur 3 (lot 2) ou 5 (lot 5) jours.

TABLEAU V. TESTS DE MARQUAGE A L'IRIDIUM DU CHARANÇON DE LA TIGE REALISES EN 1985

(Symboles comme sur le tableau I)

	0	+	*	**	Total
	-	10	106	10	126
‡	-	8	84	8	100

3.1.2. Charançon de la tige

Le maintien des adultes sur brins de colza coupés ne présente pas non plus de grandes difficultés.

En 1984, après un marquage de 2 jours on obtient une proportion élevée d'insectes bien marqués juste après marquage, de même que 8 jours après (tableau III).

En 1985, on maintient en élevage 7 lots d'insectes (275 charançons) pendant un temps allant de 20 jours à plus de 2 mois (lots 2 à 5). On observe un bon taux de survie chez les insectes marqués par rapport aux témoins (tableau IV). Les charançons sont marqués pendant 3 à 5 jours. Les tests de marquage portent sur un échantillonnage de 126 charançons (sur 187 marqués) dont 68 sont morts en cours d'élevage (sur 83 au total) et 58 sont sacrifiés (sur 104 au total). On n'observe aucun charançon non marqué, et seulement 10 animaux faiblement marqués (tableau V). On ne remarque pas d'atténuation du marquage avec le temps.

Avec l'altise comme avec le charançon, on vérifie qu'il est possible de déceler la radioactivité liée à un ou plusieurs insectes marqués mêlés à d'autres insectes non marqués si l'on opère par fragmentations successives. Ceci nécessite que le bruit de fond dû aux radioéléments à courte période soit suffisamment atténué. La première détection peut être pratiquée à partir de la gélule utilisée pour la radioactivation, dont la contenance peut aller jusqu'à 30 insectes.

On a par ailleurs examiné à deux reprises 23 charançons activés en décembre 1984. Au deuxième examen, plus de 6 mois après l'activation, on retrouve les premiers résultats: 2 insectes faiblement marqués et 21 insectes marqués (avec le même temps de lecture de 60 s).

3.2. Marquage des insectes à l'azote 15

La méthode est appliquée à l'altise d'hiver en simple ou double marquage.

Le marquage simple réalisé en 1983 avec un sel d'ammonium à teneur isotopique de 99% conduit à d'excellents résultats (tableau VI): sur 16 insectes sacrifiés

TABLEAU VI. EXCES ISOTOPIQUE D'AZOTE 15 (%) CHEZ 16 ALTISES D'HIVER PRELEVEES DANS LES ELEVAGES DE 1983 (S31, cf. TABLEAU I)

Femelles	6.72	7.13	8.13	8.54	8.19	4.39	8.60	6.94	9.05
Mâles	6.87	5.05	7.68	6.04	9.13	3.88	8.22		

TABLEAU VII. EXCES D'AZOTE 15 (%) CHEZ 49 ALTISES D'HIVER PRELEVEES DANS LES ELEVAGES DE 1984 (S41, S42, S43, cf. TABLEAU II)

S41	2.24	0.88	0.13	2.49	1.65	2.49	
	3.86	1.68	1.19	0.11	0.39	3.18	
	1.69	0.18	0.01	0.07	0.91	0.00	
S42	0.89	0.35	0.33	0.95	0.23	1.46	
	2.13	-0.08	1.36	2.07	0.26	0.05	
	0.05	1.35	1.28	1.48	0.01	0.16	
S43	0.61	-0.10	1.90	0.21	0.52	-0.04	0.66
	0.94	0.36	1.05	0.11	0.58	-0.00	

3 jours après le marquage (S31), on mesure des excès isotopiques particulièrement élevés, de 3,88 à 9,13%, comparés à la limite inférieure de détection qui se situe vers 0,2%. Les mesures sont réalisées sur un demi-élytre pour chaque insecte. Au préalable on vérifie sur un animal éclaté que toutes les parties du corps sont marquées. Les mesures faites sur un insecte sont les suivantes: tête, 3,91%; thorax, 6,57%; élytre, 8,30%; aile membraneuse et muscles alaires, 5,10%; patte postérieure, 3,44%; abdomen, 5,99%.

Le double marquage iridium et azote 15 expérimenté en 1984 utilise un sel d'ammonium à teneur isotopique de 50%. Les résultats indiquent que 15 des 49 altises marquées (31%) ne sont pas différenciées des témoins (tableau VII).

4. DISCUSSION ET CONCLUSION

L'iridium présente l'intérêt de résider longtemps dans le corps de l'animal. Il offre aussi la possibilité de déceler un insecte marqué au sein d'un lot d'insectes non marqués, ce qui permet de réaliser les mesures de détection sur des effectifs importants.

Cependant, avec l'iridium, le niveau de détection du marquage est très variable. Pour le charançon, il est satisfaisant et assez stable dans le temps; pour l'altise, il est plus faible et moins persistant. Il se trouve que les résultats inverses conviendraient mieux aux études de lâcher-recapture.

Le marquage de l'altise doit être réalisé au moment où les insectes, prélevés dans les cultures, passent d'une phase de constitution de réserves à une entrée en diapause progressive. L'absorption de nourriture peut donc ne pas être optimale pour l'ensemble ou une partie des animaux. Un élevage à partir de larves âgées permettrait d'obtenir des adultes pouvant être marqués dès leur première alimentation. Cependant, nous avons eu le souci d'apporter un minimum de perturbations au déroulement naturel des cycles de développement. Le manque de rémanence du marquage est un handicap gênant dans les expériences de lâchers-recaptures où les insectes sont piégés en quantités convenables pendant un à deux mois après leur reprise d'activité, soit trois à quatre mois après le marquage.

Le marquage du charançon est pratiqué sur des insectes qui sont en pleine période de vol, à un moment où l'alimentation et le métabolisme sont intenses. La qualité et la bonne persistance du marquage sont des points avantageux. Dans les expériences de lâchers-recaptures sur cet insecte, les problèmes interviennent au moment des lâchers car, en début d'année, les conditions favorables au vol qui sont mises à profit pour récupérer les insectes ne persistent généralement pas. Après les quelques jours de captivité nécessaires au marquage, les lâchers s'intègrent mal à la dynamique naturelle des populations étudiées. L'obtention d'adultes à partir de larves âgées permettrait là encore d'obtenir des animaux susceptibles d'être marqués dès leur reprise d'activité, stimulée ou non, et de faire des lâchers dans de bonnes conditions de vol.

TABLEAU VIII. ESTIMATION DES POURCENTAGES D'INSECTES MARQUES CORRESPONDANTS AUX DIFFERENTS LACHERS D'INSECTES REALISES EN 1983, 1984 ET 1985
(Symboles comme sur le tableau I)

LACHER	ALTISE (1)		CHARANCON	
	1983	1984	1984	1985
IRIDIUM	+	+ -	+	+
AZOTE 15	-	- +	-	-
marqués (+)	5	29	-	9
bien marqués (*,**)	90	42 61	91	

(1) : Chiffres obtenus après la reprise d'activité.

L'azote 15 ne présente pas le même intérêt que l'iridium car sa détection nécessite la préparation de chaque insecte testé. C'est cependant un excellent marqueur en second à n'utiliser que chez des individus déjà marqués à l'iridium. Après de bons résultats en 1983, la réduction de la teneur isotopique du sulfate d'ammonium utilisé en 1984 a entraîné un marquage moins satisfaisant.

Les expériences de lâchers-recaptures pour lesquelles ces essais étaient destinés étaient prévues dans un site expérimental isolé où l'on disposait d'environ 5 hectares de colza chaque année. On cherchait à préciser l'évolution quantitative, dans l'espace et dans le temps, des deux ravageurs du colza d'hiver dont il est question ici. Il s'agissait, en particulier, d'expliquer les disparités de niveaux d'invasion souvent constatées d'un champ à l'autre et d'en tirer des enseignements sur les recommandations en matière de surveillance des cultures (Collaboration CETIOM, Université Claude-Bernard, Lyon). Faute de temps, les essais de marquage et les expériences de lâchers-recaptures [9] ont été réalisées simultanément. Les vérifications faites sur les animaux d'élevage échantillonnés à partir des lâchers permettent de supposer que dans trois cas sur quatre, les insectes libérés étaient marqués de façon satisfaisante (tableau VIII).

REMERCIEMENTS

Les auteurs souhaitent remercier le docteur G. Guiraud pour son assistance dans l'analyse de l'azote 15.

REFERENCES

- [1] THIOULOUSE, J., DEBOUZIE, D., BALLANGER, Y., Structures spatiales et temporelles des populations d'un ravageur du colza (*Psylliodes chrysocephala* L., Col., Chrysomelidae) dans plusieurs parcelles de cultures, Acta Oecol. (Oecol. Appl.) 5 4 (1984) 335.
- [2] THIOULOUSE, J., DEBOUZIE, D., BALLANGER, Y., Structures spatio-temporelles d'une population de *Ceuthorrhynchus napi*, insecte ravageur du colza, Comptes rendus du 7^e Congrès international du colza, 1986, Poznan, Groupe consultatif international de recherche sur le colza, Pologne (à paraître).
- [3] TAIMR, L., SEDIVY, J., BERGMANNOVA, E., HANKER, I., Further experience obtained in studies on dispersal flights of *Meligethes aeneus* F. marked with P32 (Coleoptera), Acta Entomol. Bohemoslov. 5 (1967) 325.
- [4] KUHNE, W., Eine Methode zur radioaktiven Massenmarkierung von *Meligethes spec.* mit P32, Beitr. Entomol. 18 (1968) 259.
- [5] SYLVEN, E., Field movement of radioactively labelled adults of *Dasyneura brassicae* Winn. (Dipt., Cecidomyiidae), Entomol. Scand. 1 (1970) 161.
- [6] IPERTI, G., BUSCARLET, L.A., Contribution à l'étude d'une migration d'*Adonia 11 notata* Schn. (Coleoptera, Coccinellidae) par marquage avec l'iridium 191 stable, Ann. Zool. Ecol. Anim. 4 2 (1972) 249.
- [7] LASCEVE, G., BUSCARLET, L.A., BOSSY, A., Analyse par radioactivation de carpacapses marqués avec de l'iridium 191, Int. J. Appl. Radiat. Isot. 22 (1972) 265.

- [8] RUHM, M.E., GINGRICH, R.E., SEBASTIANELLI, J.A., Tagging the brown plant hopper, *Nilaparvata lugens*, with the stable isotope nitrogen-15: Method for labelling and detection, Entomol. Exp. Appl. 33 (1983) 117.
- [9] BALLANGER, Y., BUSCARLET, L.A., Marquage des insectes du colza d'hiver. Expériences de lâchers-recaptures, Comptes rendus du 7^e Congrès international du colza, 1986, Poznan, Groupe consultatif international de recherche sur le colza, Pologne (à paraître).

NUTRITIONAL AND ECOLOGICAL RESEARCH USING NUCLEAR TECHNIQUES FOR THE CONTROL OF THE OLIVE FRUIT FLY

A.G. MANOUKAS
Institute of Biology,
Nuclear Research Center Demokritos,
Athens, Greece

Abstract

NUTRITIONAL AND ECOLOGICAL RESEARCH USING NUCLEAR TECHNIQUES FOR THE CONTROL OF THE OLIVE FRUIT FLY.

Instrumental neutron activation analysis was used to determine the mineral composition of the olive fruit fly and of its food. The contents of the natural (olive fruit) and artificial food of larvae were determined for the presence of Na, K, Ca, Mg, Mn, Fe, Zn and Cu. It was found that the natural food contained 26 times less Na, 20 times less Cu and double the amount of K compared with the artificial diet. In addition Mn, Cu, Al, Cr, Zn, Co and Rb contents in newly emerged and unfed olive fruit flies grown as larvae under natural and laboratory conditions were determined. It was found that the two types of insects differed in the quantities of the first five elements. The significance of these results and the limiting factors involved in studying the nutrition and ecology of this insect are discussed.

1. INTRODUCTION

The contribution of nuclear science and technology in solving research problems relative to plant protection from insects is well known. Considerable work has been done in Greece and elsewhere on the control of the olive fruit fly using methods which would minimize environmental pollution. Most of the effort at the Nuclear Research Center Demokritos (NRC) was concentrated in the past on research leading to the application of the Sterile Insect Technique (SIT). The first experimental field application of SIT gave questionable results [1] and subsequent applications showed that released sterile insects failed to suppress the wild population and protect the olive fruit. This prompted initiation of research to evaluate the detrimental effects of the artificial rearing system [2, 3] and irradiation [4, 5] on the quality and the performance of the released insect. Some of these effects [6,7,8] may best be investigated with nuclear technology. In early work [9], ^{32}P was used in food uptake studies and since then radiochemicals have been used on many occasions. Emphasis has been given to biochemistry, nutrition and ecology.

Minerals are essential in nutrition and metabolism of all organisms, including insects. Minerals are also important as

biological markers in studying dispersal, behavior and other ecological aspects. This report will give results on the mineral composition of the olive fruit fly Dacus oleae Gmelin and its larval food using instrumental neutron activation analysis (INAA).

2. MATERIALS AND METHODS

Olive fruit collected from the Greek variety 'Konservolia' and 'Koroneiki' of Olea europaea L. were used. A description of the ecology and characteristics is given elsewhere [10]. Collection of fruits was made randomly from three to five trees of each variety and at a similar stage of maturity. This stage could support growth of the olive fruit fly larvae. The mesocarp of the fruits was homogenized, defatted and dried prior to the analysis. The calculation of the mineral content of the artificial food of the olive fruit fly larvae was based on the analysis of brewer's yeast and soy-hydrolysate, which were the main dietary components [11]. Male and female newly emerged and unfed olive fruit flies obtained from larvae grown under natural conditions (in olive fruit) were designated as 'wild' and those obtained from an artificial diet [12] were designated as 'lab'. The wild and lab adults were dried and prepared for analysis. Preparation of samples was done by standard procedures [13] and 50 mg to 200 mg were used for each analysis. At least three samples of each mineral were counted and standard statistical procedures [14] were employed.

The application of INAA for determining the minerals reported here was done according to the procedures described previously [15, 16]. Neutron irradiation was carried out in the NRC swimming pool reactor using the pneumatic transfer system.

3. RESULTS AND DISCUSSION

Table I presents the mineral composition of the two varieties of olive fruit analysed in this study. It also presents the composition of a third variety of fruit, together with that of the artificial food for the olive fruit fly larvae determined in a previous study [11]. Based on statistical evaluation of unequal variances and unequal observations [14], it can be concluded that, with the exception of Ca and Cu, all three varieties of the olive fruit contained equivalent amounts of minerals. Since many factors are involved in the mineral composition of fruits no explanation can be offered for the difference in Ca and Cu among the three varieties.

A comparison of the inorganic nutritional elements determined in the natural food (olive fruit) of the olive fruit fly

TABLE I. INORGANIC NUTRITIONAL ELEMENTS IN THE NATURAL (OLIVE FRUIT) AND ARTIFICIAL FOOD OF THE OLIVE FRUIT FLY LARVAE^a

Element	Olive Variety			Artificial food ^b
	Konser- volia	Koro- neiki	Mega- ritiki ^b	
Na	5.6± 1.7	3.9± 0.7	3.2± 1.0	82.4
K	525.9±39.1	485.3±29.6	457.2± 6.1	214.5
Ca	14.3± 1.6	25.6± 1.8	33.2± 0.7	33.5
Mg	16.1± 3.4	11.7± 6.7	12.5± 5.5	29.7
Mn	0.1±0.01	0.1± 0.02	0.1± 0.01	0.2
Fe	1.6±0.2	1.8± 0.2	1.2± 0.1	1.6
Zn	0.9±0.2	0.6± 0.1	0.7± 0.1	0.9
Cu	0.1±0.01	0.05±0.01	0.01±0.00	0.2

^aDetermined by Neutron Activation Analysis and expressed in mg/100 g fresh weight ± SEM.

^bReported elsewhere [11].

TABLE II. TRACE ELEMENTS IN NATURALLY GROWN (WILD) AND LABORATORY REARED (LAB) AS LARVAE OLIVE FRUIT FLY ADULTS^a

Element	Wild			Lab		
	Male	Female	Mean	Male	Female	Mean
Mn	86	83	84.5*	60	52	56.0*
Cu	68	82	75.0*	34	54	44.0*
Al	227	188	207.5*	99	113	106.0*
Cr	0.42	0.27	0.35*	0.70	0.60	0.65*
Zn	381	402	392*	669	653	661*
Co	0.01	0.01	0.01	0.01	0.01	0.01
Rb	4.33	4.28	4.31	4.32	3.84	4.08

^aDetermined by Neutron Activation Analysis in ppm on a dry matter basis.

*Indicates statistically significant differences at 0.05 level of probability

larvae with those of the artificial food reveals certain differences which may be important in larval nutrition and metabolism. Thus the natural food contains much more K and twenty-six times less Na and twenty times less Cu than the artificial diet. This situation may create a mineral imbalance or toxicity problem. The difficulties involved in investigating such a problem have been discussed previously [17]. It should be mentioned, however, that the tolerance of the olive fruit fly larvae to Na and Cu was, respectively, 24.4 and 50.0 times the amount found in the olive fruit. The tolerance of larvae for these and other minerals [18] may help in deciding which elements could be used as biological markers or 'chemoprints' in the olive fruit fly for ecological studies.

Table II presents the trace elements determined in naturally grown (wild) and artificially reared (lab) male and female olive fruit flies. The data in this table showed that the mineral profile between males and females in both types of insects was not significantly different, probably because of high variation. On the other hand, comparison of the means for wild and lab insects showed significant differences in Mn, Cu, Al, Cr and Zn. Presumably these differences could be used to distinguish between wild and lab olive fruit flies when released and captured in the orchards. It should be emphasized, however, that before such use is made the mineral compositions of naturally grown and artificially reared insects should be investigated in great detail under many dietary and environmental conditions. It must be remembered that the insects in this study were grown under a certain set of conditions and the adults were analysed prior to ingestion of any food or water. In addition, although the larva is monophagous, its adult is polyphagous.

It is known that the elemental composition of an insect may or may not be influenced by the food ingested or by other environmental factors. If an influence is found to exist for one mineral, it will be possible to use that mineral as a biological marker under well defined conditions. The possible use of stable elements in marking insects has been proposed and studied by many investigators. Pupal Mediterranean fruit flies showed different manganese contents as a result of different natural concentrations of manganese in the larval diet [19]. Other investigators working with monophagous or oligophagous insects have suggested that populations from different localities could be identified by differences in certain elements [20, 21]. On the other hand, extensive work with polyphagous moths demonstrated that the larval host plant is a significant factor in the mineral composition of the adult, but is limiting and confounding with respect to the geographical source [22].

REFERENCES

- [1] ECONOMOPOULOS, A.P., AVTZIS, N., ZERVAS, G., TSITSIPIS, J., HANIOTAKIS, G., TSIROPOULOS, G. and MANOUKAS, A.G., Control of the olive fruit fly, Dacus oleae (Gmelin), by the combined effect of insecticides and release of γ -sterilized insects, Z. Angew. Entomol. 83 (1977) 201
- [2] TSITSIPIS, J.A., "Changes of a wild ecotype of the olive fruit fly during adaptation to lab rearing", Fruit Flies of Economic Importance (Proc. Int. Symp. Athens, 1982) (CAVALLORO, R., Ed.), Vol. 1, A.A. BALKEMA/Rotterdam (1983) 416-422.
- [3] MANOUKAS, A.G., "The adaptation process and the biological efficiency of Dacus oleae larvae", Fruit Flies of Economic Importance (Proc. Int. Symp. Athens, 1982) (CAVALLORO, R., Ed.), Vol. 1, A.A. BALKEMA/Rotterdam (1983) 91-95.
- [4] ECONOMOPOULOS, A.P., Gamma-ray sterilization of Dacus oleae (Gmelin). Effect of nitrogen on the competitiveness of irradiated males, Z. Angew. Entomol. 83 (1977) 86.
- [5] ZERVAS, G.A., ECONOMOPOULOS, A.P., Mating frequency in caged populations of wild and artificially reared (normal or γ -sterilized) olive fruit flies, Environ. Entomol. II (1982) 17.
- [6] MANOUKAS, A.G., "Biological and Biochemical parameters of the olive fruit fly with reference to larval nutritional ecology", Fruit Flies of Economic Importance (Proc. Int. Symp. Athens, 1982) (CAVALLORO, R., Ed.), Vol. 1, BALKEMA/Rotterdam (1983) 410-415.
- [7] TSIROPOULOS, G.J., Quality problems associated with the mass production of Dacus oleae, Z. Angew. Entomol. 90 (1980) 413.
- [8] ECONOMOPOULOS, A.P., ZERVAS, G.A., "The quality problem in olive flies produced for SIT experiments" Sterile Insect Technique and Radiation in Insect Control (Proc. Int. Symp. Neuherrberg, 1982), IAEA, Vienna (1982) 357-368.
- [9] TZANAKAKIS, M.E., Food uptake studies with the olive fruit fly, Dacus oleae (Gmelin), using P-32 labelled food, IAEA Res. Contract 436/RB, Final Report 436/RB (1968).
- [10] ANAGNOSTOPOULOS, P.T., The varieties and the ecology of the olive tree in Greece, Agric. Coll. Bull., Athens (1939) (in Greek).
- [11] MANOUKAS, A.G., GRIMANIS, A., MAZOMENOS, B., Inorganic nutrients in natural and artificial food of Dacus oleae larvae (Diptera: Tephritidae), Ann. Zool., Ecol. Anim. 10 (1978) 123.

- [12] TSITSIPIS, J.A., An improved method for mass rearing of the olive fruit fly, Dacus oleae (Gmel), Z. Angew. Entomol. 83 (1977) 419.
- [13] ASSOCIATION OF OFFICIAL ANALYTICAL CHEMISTS, Methods of Analysis, AOAC, Arlington, VA (1955).
- [14] STEELE, R.G., TORRIE, J.H., Principles and Procedures of Statistics, McGraw-Hill, London (1960)
- [15] GRIMANIS, A.P., NIKOLAIDOU, M., VASSILAKI-GRIMANI, M., Application of Neutron Activation Analysis in the Study of Cystic Fibrosis, IAEA Research Contract 689/RB, Final Report 689/GR, Athens (1972).
- [16] GRIMANIS, A.P., VASSILAKI-GRIMANI, M., ALEXIOU, D., PAPANATOS, C., "Determination of seven trace elements in human milk, powdered cow's milk and infant foods by neutron activation analysis", Nuclear Activation Techniques in the Life Sciences (Proc. Int. Symp. Vienna, 1978) IAEA, Vienna (1979) 241-251.
- [17] MANOUKAS, A.G., "Comparison of composition of the larval food of the olive fruit fly in nature and in the laboratory" (Proc. Int. Symp. Gent, 1984), Med. Fac. Landbouwn. Rijksumiv, 49/3a (1984) 643.
- [18] MANOUKAS, A.G., Effect of excess levels of inorganic salts upon survival, growth and pupal yield of Dacus oleae (Gmel) larvae, Z. Angew. Entomol. 93 (1982) 208.
- [19] MONRO, J., Marking insects with dietary manganese for detection by neutron activation analysis, Ecology 49 (1968) 774.
- [20] McCLEAN, J.A., BENNETT, R.B., Characterization of two Gnathotrichus sulcatus populations by x-ray energy spectrometry, Environ. Entomol. 7 (1978) 93.
- [21] TURNOCK, W.J., GERBER, G.H., BICKIS, M., BENNETT, R.B., The applicability of x-ray energy-dispersive spectroscopic studies of the red turnip beetle, Entomoscelis americana (Coleoptera:Chrysomelidae), Can. Entomol. 112 (1979) 609.
- [22] SHERLOCK, P.L., BOWDEN, J., DIGBY, P.G.N., Studies of elemental composition as a biological marker in insects IV. The influence of soil type and host-plant on elemental composition of Agrotis segetum (Denis and Schiffermüller) (Lepidoptera:Noctuidae), Bull. Entomol. Res. 75 (1985) 675.

CHAIRMEN OF SESSIONS

Session 1	L.E. LaCHANCE	FAO/IAEA
Session 2	T.K. MUKIAMA	Kenya
Session 3	C.O. CALKINS	United States of America
Session 4	M.J. WHITTEN	Australia
Session 5	W.J. KLOFT	Federal Republic of Germany
Session 6	S. BARBOSA	FAO
Session 7	C.P. SCHWALBE	United States of America
Session 8	J.M.M. WALDER	Brazil

SECRETARIAT OF THE SYMPOSIUM

Scientific Secretary:	D.A. LINDQUIST	Joint FAO/IAEA Division of Isotope and Radiation Applications of Atomic Energy for Food and Agricultural Development, IAEA, Vienna
Scientific Co-Secretary:	S. BARBOSA	Food and Agriculture Organization of the United Nations, Rome
Administrative Secretary:	A. SOKOL	Division of External Relations, IAEA, Vienna
Proceedings Editor:	G.V. RAMESH	Division of Publications, IAEA, Vienna
French Editor:	J.-N. AQUISTAPACE	
Spanish Editor:	L. HERRERO	

LIST OF PARTICIPANTS

- Abdallah Moh. Al-Ajmah
Agriculture Extension Service,
Ministry of Agriculture and Water,
Riyadh, Saudi Arabia
- Abo-Zuhairah, Radhi
Regional Agriculture and Water Research Centre,
P.O. Box 17285,
Riyadh 11484, Saudi Arabia
- Adnan Sulciman Khan
Agricultural Research Centre,
Jeddah, Saudi Arabia
- Ahmed, M.S.H.
Faculty of Agriculture and Biology,
Nuclear Research Centre,
P.O. Box 765,
Baghdad, Iraq
- Ahmed, M.Y.Y.
Radiobiology Department,
Nuclear Research Centre,
Atomic Energy Establishment,
101, Kasr El-Einy Street,
Cairo, Egypt
- Alford, A.R.
Department of Entomology.
Deering Hall,
University of Maine,
Orono, Maine 04469, United States of America
- Al Tarakma, Yousuf
Agriculture Affairs and Fish Resources Authority,
P.O. Box 21422 Safat,
13075 Safat, Kuwait
- Anisimov, A.I.
All-Union Institute of Plant Protection,
Podbelskij 3, Pushkin-6, Leningrad,
Union of Soviet Socialist Republics
- Barbosa, S.
Food and Agriculture Organization of the United Nations,
Via delle Terme di Caracalla,
I-00100 Rome, Italy
- Bartlett, A.C.
Western Cotton Research Laboratory,
Agricultural Research Service,
United States Department of Agriculture,
4135 East Broadway Road,
Phoenix, Arizona 85040,
United States of America

- Bauer, B. CRTA-GTZ, Project Glossines,
B.P. 454,
Bobo-Dioulasso, Burkina Faso
- Biraghi, C. Osservatorio Malattie Piante di Milano,
Via Moretto da Brescia 7,
I-20133 Milan, Italy
- Bughio, A.R. Atomic Energy Agricultural Research Centre,
Tandojam, Sind, Pakistan
- Buscarlet, L.A. Centre d'études nucléaires de Cadarache
(DBISRA),
Commissariat à l'énergie atomique,
F-13108 Saint-Paul-lez-Durance, France
- Busch-Petersen, E. FAO/IAEA Entomology Unit,
IAEA Seibersdorf Laboratory,
P.O. Box 100,
A-1400 Vienna, Austria
- Calkins, C.O. Insect Attractants, Behavior and
Basic Biology Research Laboratory,
Agricultural Research Service,
United States Department of Agriculture,
P.O. Box 14565,
Gainesville, Florida 32604,
United States of America
- Carle, P.R. PROCIDA-ROUSSEL UCLAF,
St. Marcel, B.P. 1,
F-13367 Marseilles Cedex 11, France
- Chen, J.D. Whiteshell Nuclear Research Establishment,
Atomic Energy of Canada Ltd,
Pinawa, Manitoba R0E 1L0, Canada
- De Loach, J. United States Department of Agriculture,
P.O. Drawer and E,
College Station, Texas 77840,
United States of America
- Doane, J.F. Research Station,
Agriculture Canada,
107 Science Crescent,
Saskatoon, Saskatchewan S7N 0X2, Canada
- Duffaud, P. Service régional de la protection des végétaux,
Service régionale de l'agriculture et de la forêt,
24, rue Edouard Delangleade,
F-13006 Marseilles, France

- Economopoulos, A.P. FAO/IAEA Entomology Unit,
IAEA Seibersdorf Laboratory,
P.O. Box 100,
A-1400 Vienna, Austria
- Fischer-Colbrie, P. Bundesanstalt für Pflanzenschutz,
Trunnerstrasse 1-5,
A-1020 Vienna, Austria
- Genchev, N. Plant Protection Institute,
P.O. Box 238,
2230 Kostinbrod,
Sofia, Bulgaria
- Gingrich, R.E. FAO/IAEA Entomology Unit,
IAEA Seibersdorf Laboratory,
P.O. Box 100,
A-1400 Vienna, Austria
- Goicoechea, J.L. Centro Nacional de Sanidad Agropecuaria,
Carretera de Tapaste y Autopista Nacional,
San José de Las Lajas, Apartado 10,
Havana, Cuba
- Grigorian, E. Armenian Research Institute of Plant Protection,
Yerevan, Union of Soviet Socialist Republics
- Hamann, H.J. Internationales Büro,
Gesellschaft für Strahlen- und Umweltforschung mbH,
Ingolstädter Landstrasse 1,
D-8042 Neuherberg, Federal Republic of Germany
- Hentze, F. Programa Moscamed,
6a Calle 1-36, Zona 10,
Edificio Valsari OF 203,
Guatemala City, Guatemala
- Höbaus, E. Bundesanstalt für Pflanzenschutz,
Trunnerstrasse 1-5,
A-1020 Vienna, Austria
- Ignatowicz, S. Department of Applied Entomology,
Agricultural University of Warsaw,
ul. Nowoursynowska 166,
PL-02-766 Warsaw, Poland
- Kabayo, J.P. FAO/IAEA Entomology Unit,
IAEA Seibersdorf Laboratory,
P.O. Box 100,
A-1400 Vienna, Austria

- Kim, J.I. Genetic Engineering Center,
Korea Advanced Institute of Science and Technology,
P.O. Box 131, Cheongryang,
Seoul, Republic of Korea
- Kloft, W.J. Institut für Angewandte Zoologie,
Universität Bonn,
An der Immenburg 1,
D-5300 Bonn, Federal Republic of Germany
- Komson, Puangpaka Export Plant Quarantine Service,
Agricultural Regulatory Division,
Department of Agriculture Bangkok,
Ministry of Agriculture and Cooperatives,
Bangkok 10900, Thailand
- Kuria, R.M. Pyrethrum Board of Kenya,
P.O. Box 420,
Nakuru, Kenya
- LaChance, L.E. Joint FAO/IAEA Division of Isotope and Radiation
Applications of Atomic Energy for Food and
Agricultural Development,
International Atomic Energy Agency,
P.O. Box 100,
A-1400 Vienna, Austria
- Le Berre, R. World Health Organization,
Avenue Appia,
CH-1211 Geneva 27, Switzerland
- Li, Y.Y. Institute for Application of Atomic Energy,
Chinese Academy of Agriculture,
P.O. Box 5109,
Beijing, China
- Luger, D. FAO/IAEA Entomology Unit,
IAEA Seibersdorf Laboratory,
P.O. Box 100,
A-1400 Vienna, Austria
- Madubunyi, L.C. Department of Veterinary Parasitology and Entomology,
Faculty of Veterinary Medicine,
University of Nigeria,
Nsukka, Nigeria
- Malacrida, A.R. Dipartimento di Biologia Animale,
Università di Pavia,
Piazza Botta 9,
I-27100 Pavia, Italy

- Manoukas, A.G. Institute of Biology,
Nuclear Research Center Demokritos,
Greek Atomic Energy Commission,
Aghia Paraskevi, Attiki,
P.O. Box 60228,
Athens 16450, Greece
- McInnis, D.O. Tropical Fruit and Vegetable Research Laboratory,
Agricultural Research Service,
United States Department of Agriculture,
P.O. Box 2280,
Honolulu, Hawaii 96804,
United States of America
- Mekdoud, R. Laboratoire des denrées stockées,
Chemin d'Artigues,
F-33152 Cenon, France
- Moloo, S.K. International Laboratory for Research
on Animal Diseases,
P.O. Box 30709,
Nairobi, Kenya
- Mouchès, C. Station de recherches de nématologie et de génétique
moléculaire des invertébrés,
123, boulevard F. Meilland , B.P. 2078,
F-06606 Antibes Cedex, France
- Mukiama, T.K. Department of Botany,
University of Nairobi,
P.O. Box 30197,
Nairobi, Kenya
- Offori, E.D. Insect and Pest Control Section,
Joint FAO/IAEA Division of Isotope and Radiation
Applications of Atomic Energy
for Food and Agricultural Development,
International Atomic Energy Agency,
P.O. Box 100,
A-1400 Vienna, Austria
- Oladunmade, M. BICOT-VOM,
P.O. Box 76,
Plateau State, Vom, Nigeria
- Randrianandrianina, R. Centre national de recherches appliquées
au développement rural,
B.P. 1444,
Tananarive, Madagascar

LIST OF PARTICIPANTS

- Reyes, J. Programa Moscamed,
2a avenida sur 5-3,
Apartado 368,
Tapachula, Chiapas,
37000 Mexico
- Robinson, A.S. Institute of Molecular Biology and Biotechnology,
Research Center of Crete,
P.O. Box 1527,
71110 Heraklion, Crete, Greece
- Rodríguez Vargas, M. Permanent Mission of Colombia to the IAEA,
Stadiongasse 6-8,
A-1010 Vienna, Austria
- Rosada, J. Radioisotope Laboratory,
Plant Protection Institute,
ul. Miczurina 20,
PL-60-318 Poznań, Poland
- Rössler, Y. The Israel Cohen Institute for Biological Control,
Citrus Marketing Board of Israel,
27 K.K.L. Street,
Rehovot 76345, Israel
- Schwalbe, C.P. Animal and Plant Health Inspection Service,
United States Department of Agriculture,
Otis Methods Development Center,
Otis Air National Guard Base,
Massachusetts 02542, United States of America
- Seawright, J.A. Insects Affecting Man and Animals Laboratory,
Agricultural Research Service,
United States Department of Agriculture,
P.O. Box 14565,
Gainesville, Florida 32604,
United States of America
- Sipat, A.B. Department of Biotechnology,
Universiti Pertanian Malaysia,
43400 Serdang, Selangor, Malaysia
- Snow, J.W. Southeastern Fruit and Tree Nut Research Laboratory,
Agricultural Research Service,
United States Department of Agriculture,
P.O. Box 87,
Byron, Georgia 31008,
United States of America

AUTHOR INDEX

- Ahmed, M.S.H.: 102, 357
Ahmed, M.Y.Y.: 263
Akman, K.: 293
Aleman, J.: 307
Al-Taweel, A.A.: 285, 357
Anisimov, A.I.: 65, 423
Auda, H.: 357
Ballanger, Y.: 451
Barnor, H.: 277
Bartlett, A.C.: 85
Baruffi, L.: 221
Bauer, B.: 139
Biscaldi, G.F.: 221
Bruzzone, N.D.: 285
Buglio, A.R.: 413
Buscarlet, L.A.: 325, 395, 451
Busch-Petersen, E.: 211
Calkins, C.O.: 299
Chin, P.K.: 427
Courtright, J.B.: 251
Cugier, J.-P.: 325
Draz, K.A.A.: 299
Ducom, P.: 325
Economopoulos, A.P.: 285
El-Abbassi, T.S.: 77
El-Agal, M.N.: 285
El-Kady, E.A.: 263
El-Refai, S.A.: 263
Fraga, Y.: 307
Gao, M.K.: 271
Gasperi, G.: 221
Genchev, N.: 387
Gingrich, R.E.: 77
Goicoechea, J.L.: 307
Grace, C.R.: 251
Hameed, A.A.: 357
Hasaballa, Z.A.: 263
Heilmann, L.J.: 251
Hendrichs, J.: 107
Hentze, F.: 117
Hesse, G.H.: 437
Ignatowicz, S.: 381
Judt, S.: 285
Kabayo, J.P.: 129, 277
Kaboré, I.: 139
Kafu, A.: 211
Kang, S.K.: 97
Kassis, S.R.: 395
Khoo, K.C.: 427
Kim, J.I.: 97
Kloft, W.J.: 437
Komson, Puangpaka: 319
Kourouma, B.: 139
Kučerová, Z.: 343
Kumaran, A.K.: 251
Lapasatukul, Chamlong: 319
Lazurkina, N.V.: 423
Le Berre, R.: 59
Li, Y.Y.: 403
Lou, H.Z.: 403
Louis, C.: 241
Luger, D.: 129
Madubunyi, L.C.: 151
Makishe, F.W.: 271
Malacrida, A.R.: 221
Manoukas, A.G.: 461
Mastro, V.C.: 15
Mattausch, M.: 139
McInnis, D.O.: 251
Mekdoud, R.: 325
Milani, R.: 221
Mouches, C.: 257
Mukiama, T.K.: 163
Offori, E.D.: 129

- Park, H.Y.: 97
Perez, A.: 307
Petrich-Bauer, J.: 139
Pyrek, A.: 211
Ravenel, J.L.: 395
Reyes, J.: 107
Ripfel, J.: 211
Robinson, A.S.: 241
Rosada, J.: 369
Rössler, Y.: 229
Ryoo, K.S.: 97
Savakis, C.: 241
Schwalbe, C.P.: 15
Schwarz, A.: 107
Seawright, J.A.: 179
Sedláčková, J.: 343
Shahjahan, R.M.: 195
Shvedov, A.N.: 423
Sipat, A.B.: 427
Smitasiri, Eueychai: 319
Smittle, B.J.: 299
Snow, J.W.: 3
Somé, J.: 139
Sutantawong, Manon: 319
Taher, M.: 277
Tam, S.Y.T.: 251
Tamboura, I.: 139
Tarimo, C.S.: 271
Toofanian, F.: 337
Unahawutti, Udorn: 319
Van Der Vloedt, A.M.V.: 129
Villaseñor, A.: 107
Walder, J.M.M.: 205
Wang, Hua-Song: 285
Wang, Zhenying: 281
Whitten, M.J.: 41
Wood, R.J.: 195
Wornoayporn, V.: 285
Zare, Z.: 337
Zhang, H.Q.: 403
Zhao, C.D.: 403
Zhou, Darong: 281
Zümreoğlu, A.: 293
Zuska, J.: 343

INDEX OF PAPERS AND POSTERS BY NUMBER

Papers

IAEA-SM-301/	Page	IAEA-SM-301/	Page
1	387	25	195
2	343	26	85
3	461	27	299
4	369	28	251
5	281	29	3
6	337	30	59
7	357	31	77
8	205	32	117
9	107	33	129
10	293	34	163
11	151	35	211
12	271	36	229
13	403	37	179
14	427	38	241
15	413	39	285
16	319	40	277
17	263	41	15
20	451	42	41
21	395	43	221
22	325	44	139
23	257	45	65
24	437	46	307

Posters

IAEA-SM-301/	Page	IAEA-SM-301/	Page
2P	423	10P	381
5P	97	12P	102

HOW TO ORDER IAEA PUBLICATIONS

An exclusive sales agent for IAEA publications, to whom all orders and inquiries should be addressed, has been appointed in the following country:

UNITED STATES OF AMERICA UNIPUB, 4611-F Assembly Drive, Lanham, MD 20706-4391

In the following countries IAEA publications may be purchased from the sales agents or booksellers listed or through major local booksellers. Payment can be made in local currency or with UNESCO coupons.

ARGENTINA	Comisión Nacional de Energía Atómica, Avenida del Libertador 8250, RA-1429 Buenos Aires
AUSTRALIA	Hunter Publications, 58 A Gipps Street, Collingwood, Victoria 3066
BELGIUM	Service Courrier UNESCO, 202, Avenue du Roi, B-1060 Brussels
CHILE	Comisión Chilena de Energía Nuclear, Venta de Publicaciones, Amunátegui 95, Casilla 185-D, Santiago
CHINA	IAEA Publications in Chinese: China Nuclear Energy Industry Corporation, Translation Section, P.O. Box 2103, Beijing IAEA Publications other than in Chinese: China National Publications Import & Export Corporation, Deutsche Abteilung, P.O. Box 88, Beijing
CZECHOSLOVAKIA	S.N.T.L., Mikulandska 4, CS-116 86 Prague 1 Alfa, Publishers, Hurbanovo námestie 3, CS-815 89 Bratislava
FRANCE	Office International de Documentation et Librairie, 48, rue Gay-Lussac, F-75240 Paris Cedex 05
HUNGARY	Kultura, Hungarian Foreign Trading Company, P.O. Box 149, H-1389 Budapest 62
INDIA	Oxford Book and Stationery Co., 17, Park Street, Calcutta-700 016 Oxford Book and Stationery Co., Scindia House, New Delhi-110 001
ISRAEL	Heiliger & Co. Ltd. 23 Keren Hayesod Street, Jerusalem 94188
ITALY	Libreria Scientifica, Dott. Lucio de Biasio "aeiou", Via Meravigli 16, I-20123 Milan
JAPAN	Maruzen Company, Ltd, P.O. Box 5050, 100-31 Tokyo International
PAKISTAN	Mirza Book Agency, 65, Shahrah Quaid-e-Azam, P.O. Box 729, Lahore 3
POLAND	Ars Polona-Ruch, Centrala Handlu Zagranicznego, Krakowskie Przedmieście 7, PL-00-068 Warsaw
ROMANIA	Ilexim, P.O. Box 136-137, Bucharest
SOUTH AFRICA	Van Schaik Bookstore (Pty) Ltd, P.O. Box 724, Pretoria 0001
SPAIN	Díaz de Santos, Lagasca 95, E-28008 Madrid Díaz de Santos, Balmes 417, E-08022 Barcelona
SWEDEN	AB Fritzes Kungl. Hovbokhandel, Fredsgatan 2, P.O. Box 16356, S-103 27 Stockholm
UNITED KINGDOM	Her Majesty's Stationery Office, Publications Centre, Agency Section, 51 Nine Elms Lane, London SW8 5DR
USSR	Mezhdunarodnaya Kniga, Smolenskaya-Sennaya 32-34, Moscow G-200
YUGOSLAVIA	Jugoslovenska Knjiga, Terazije 27, P.O. Box 36, YU-11001 Belgrade

Orders from countries where sales agents have not yet been appointed and requests for information should be addressed directly to:



Division of Publications
International Atomic Energy Agency
Wagramerstrasse 5, P.O. Box 100, A-1400 Vienna, Austria

INTERNATIONAL
ATOMIC ENERGY AGENCY
VIENNA, 1988

SUBJECT GROUP: I
Life Sciences/Entomology