

THE HIGH TEMPERATURE METALLIC MATERIALS PROGRAM OF THE
STATE NORTH-RHINE/WESTPHALIA

Th. Monsau

Ministerium für Wirtschaft, Mittelstand und Verkehr (MWMV)
des Landes Nordrhein-Westfalen, Germany

1. Introduction

The state North-Rhine/Westphalia is the center of energy in the Federal Republic of Germany, which disposes of great domestic resources of lignite and hard coal. It is this state government's long-term objective to save the futural supply of energy, based on these domestic resources, and to become more independent of imports of energy. It is aspired to supply in future such economical sectors, which are until now absolutely dependent on imported oil and gas, with synthetic mineral oil products or synthetic natural gas, both based on coal.

Therefore the Minister for economics, small business and transport (MWMV) promotes in the so called "Technology Programme Energy" new technologies of gasification and liquefaction of coal. Since also the coal resources of Germany are limited, the state Government of North-Rhine/Westphalia is high interested in the High Temperature Gas Cooled Reactor-Technology, because this type of reactor is not only suitable for power generation, but has in addition the potential to use it for generation of process heat at that high temperature level, which is necessary for gasification of lignite and hard coal. It is expected, that this method - gasification of coal with nuclear process heat -

is able to save about 40 % of the overall coal throughput, compared with the autothermal methods. The state government, represented by MWMV and the Federal government, represented by the Federal Minister for Research and Technology - BMFT, are sponsoring together the erection of the first demonstration plant THTR-300, which is, as known, a pebble-bed reactor for power generation, and the development-project "Prototype Plant for generation of Nuclear Process heat (PNP)".

2. Organisation of HTR-Development

The erection of the demonstration plant THTR is sponsored in common; the tasks within the project nuclear process heat are distributed between Federation and state.

The partial subjects are promoted and carried out in the responsibility of the respectively competent sponsor, but on the basis of mutual agreement and in a organization which is described later.

HTR-Development (Planning, R & D)

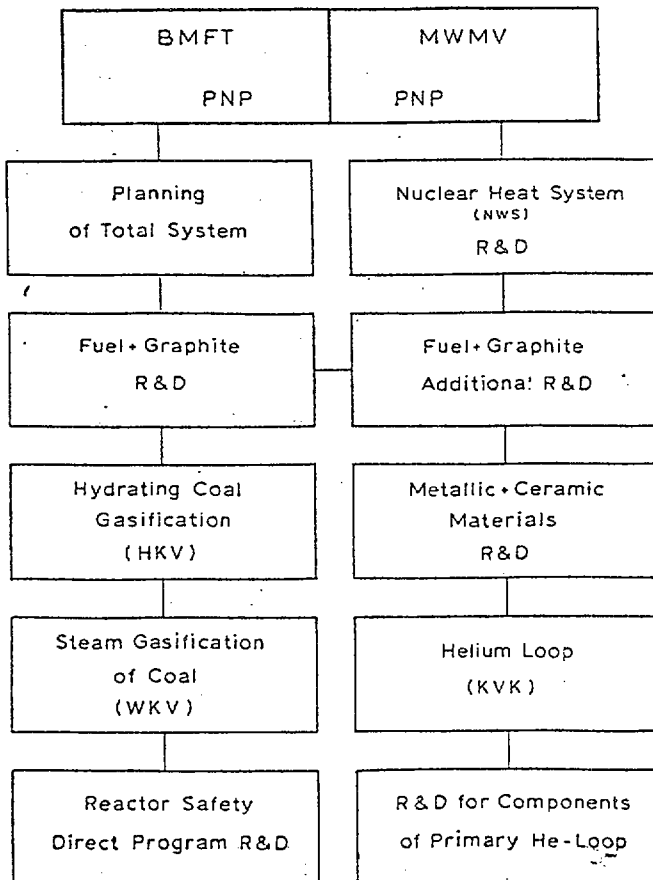

- 3 -

The Federal Minister of Research and Technology is responsible for: Planning of the total plant-system, development of fuel elements and graphite, the gasification technologies, such as hydrogenating gasification of coal, especially lignite, and the steamgasification of hard coal, finally the items in the reactor safety programme.

The state of North-Rhine/Westphalia has undertaken to promote the r & d of the nuclear heat system, including the primary components for a process-heat-reactor, additional r & d in subsections of fuel elements and graphite, the metallic and ceramic materials programme and the helium test loop for testing of components, such as helium-helium intermediate heat exchanger, steam reformer, hot gas ducts and hot gas valves.

The cooperation between promoters and the concerned industrial firms and the nuclear research center is organized as the following figure shows.

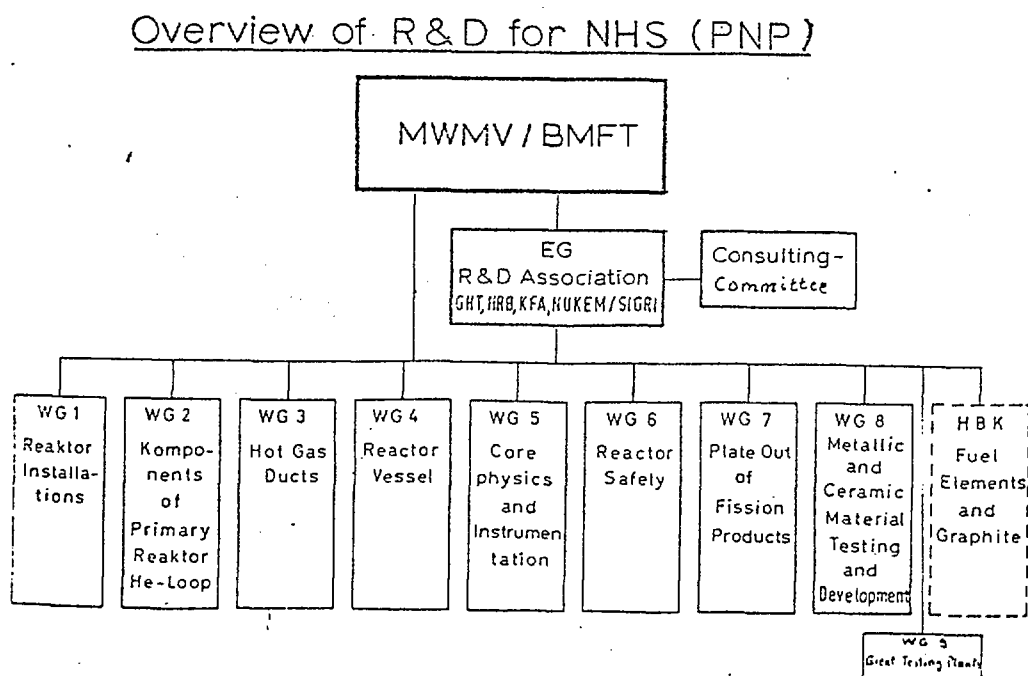

Specialists of the particular subjects cooperate in the working groups and discuss in periodical meetings the present problems and experimental details.

The tasks, which are discussed in the working groups, are supervised and coordinated by a r & d-association consisting of one manager of each partner and a coordination staff, advised by a Consulting Committee.

Representatives of the sponsors MWMV and BMFT are invited to the meetings of the working groups, the r & d-committee of the association and the consulting committee.

3. Metallic Materials

The realization of the projected Prototype Plant for Nuclear Process Heat requires large efforts during the next 6-7 years. In the development programme the metallic materials testing and developing programme represents one critical path: Without availability of suitable high temperature alloys no prototype plant is able to be built.

The components of the primary circuit are integrated in a concrete vessel and are working in a helium-gas atmosphere leaving the reactor-core with a temperature of about 950° C.

In one loop, the gasification with steam, a helium-helium intermediate heat exchanger is necessary, in the other loop for hydrogasification of lignite the steamreformer is heated directly. The requirements to the materials are dependent on the reactor conditions, some of them are now mentioned.

The geometry of He-He-exchanger tubes is characterized of thin walls and a diameter of about 25 mm, the one of the steam reformer is more than 140 mm in diameter and 15 mm wall thickness.

The helium-gas pressure will be about 40 bar, but will not differ very much in the several gas loops, the primary stresses in the heat exchanging components will be near 5 N/mm^2 under normal conditions, and the temperatures are 950° C in the IHX and 900° C in the walls of the steam-reformer.

Small impurities in the cooling gas helium are responsible to a corrosion influence on the metal, which may lead to important effects on mechanic properties.

Also the composition of the process-gas has an influence of corrosion on the materials.

The objectives of the high-temperature metallic materials programme are - based on commercial alloys - finding out qualified data of the chemical, physical and mechanical behaviour and properties of the high temperature superalloys and developing these alloys.

The programme will be carried out in three partial programmes

- basic programme
- screening programme
- alloy development programme.

All participants of the metallic material programme are shown in the following table:

Participants of the metallic material program

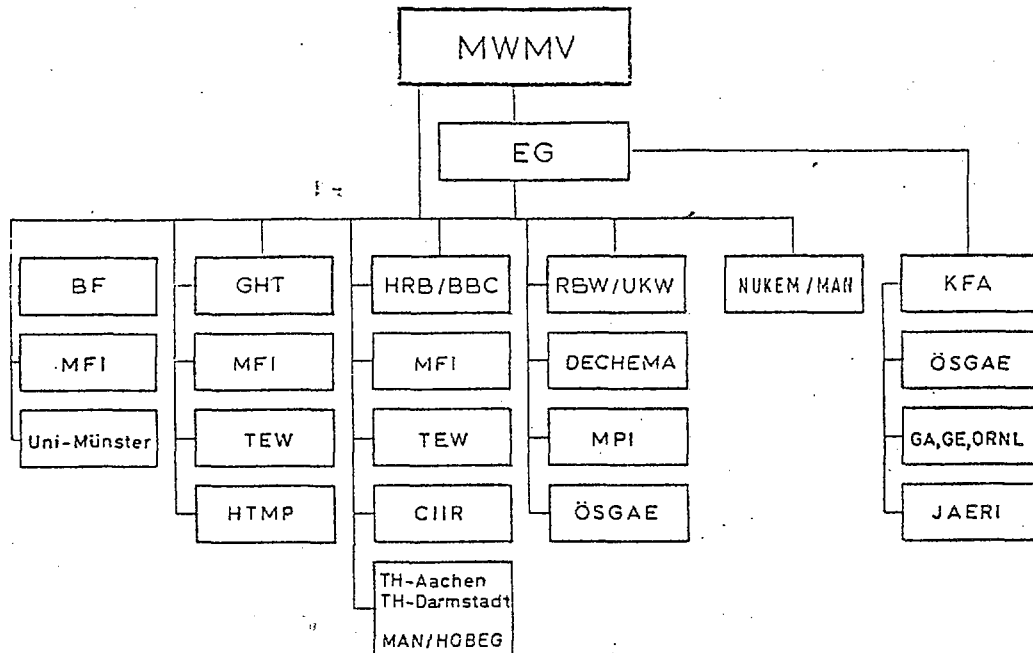

You find all partners of the FNF-Project: nuclear research center, coal companies and the reactor engineering companies, and in addition steel making companies, universities and other research institutions.

In the basic programme commercially available alloys on a iron and nickel base came into consideration and, in order to qualify the alloys, specific investigations have been done.

The alloys have been qualified according to the following criteria:

- 7 -

- manufacturability
- mechanical characteristics
- deformability
- weldability
- high temperature corrosion behaviour

Nearly parallel to this programme, a screening programme had been started. A lot of commercial or slightly modified alloys (about 40) are being tested to

- corrosion behaviour
 - in air, FNP-helium and process-gas-atmosphere
 - at temperatures up to 1000° C (Oxidation, Carburisation)
- structure stability
 - fracture strain, crack propagation
- creep rupture strength
 - time yield limit, creep rupture, creep resistance
- fatigue behaviour
 - low cycle fatigue, high cycle fatigue

The objectives of the alloy developing programme are further development or modification of commercial alloys by optimizing of their chemical composition or their metallurgical treatment. The aims are to get a better corrosion resistance of the alloys in FNP-helium and the process-gas-atmosphere, but with a tensile strength as high as the best commercial alloys Hastelloy X and Inconel 617.

We hope that for example insignificant variations of alloy components or using other elements, which are able to generate dense protecting surface layers lead to a better corrosion behaviour.

Subsequently it is aspired to increase the tensile properties of alloys which have a good corrosion resistance.

Additional activities are necessary in this programme to qualify alloys for use in reactor components, for instance:

- Tests and developments of the irradiation resistance of control rod materials, which are very close to the reactor core and therefore are in the influence of high neutron flux.
- As known, the most high temperature materials are containing Cobalt. Investigations and calculations were done, it is expected, that it is possible to reduce the neutron flux in the place of components up to an undangerous limit.
- Studies of wear and selfwelding are to be done.
- With regard to the licence procedure methods of nondestructive testing of materials have to be developed.
- In addition to the above mentioned protection layers in order to get better corrosion behaviour protection layers are necessary to reduce the permeation of Hydrogen or Tritium through the walls of the heat exchanging components.

The performance of all tasks in the metallic materials program is distributed on all participants: each of them has activities in parts of his interest or special possibilities, for example:

The coal companies investigate the behaviour in the process-gas-atmosphere, the reactor engineering companies and the nuclear research center take part in the examination of properties of materials in the primary circuit atmosphere, the FNF-helium; the steel making companies carry out the superalloy developing programme, HOEG and MAN are developing the protection surface layers to reduce permeation.

At the end I want to summarize our impression of the up to now achieved results of the high temperature materials programme:

Under the requirements of the construction heat exchanging components are able to be built with well known alloys for a lifetime of about 50000 hours, that is, in a prototype plant the heat exchanging components shall be changed after 5 - 7 years.

From the results of developing programme and of some examinations of commercial alloys we hope, that in a few years also alloys are available which have a lifetime of 15 years or more.