



Poolside Inspection

Technical Meeting, Rez, June 2003



Nuclear Fuel Cycle and Material Section



Poolside Inspection

**TM on Poolside Inspection of
Water Reactor Fuel, Rez, Czech
Rep., 10-13 June 2003-**

**Review of progress in
methodology and techniques
made during the last decade**

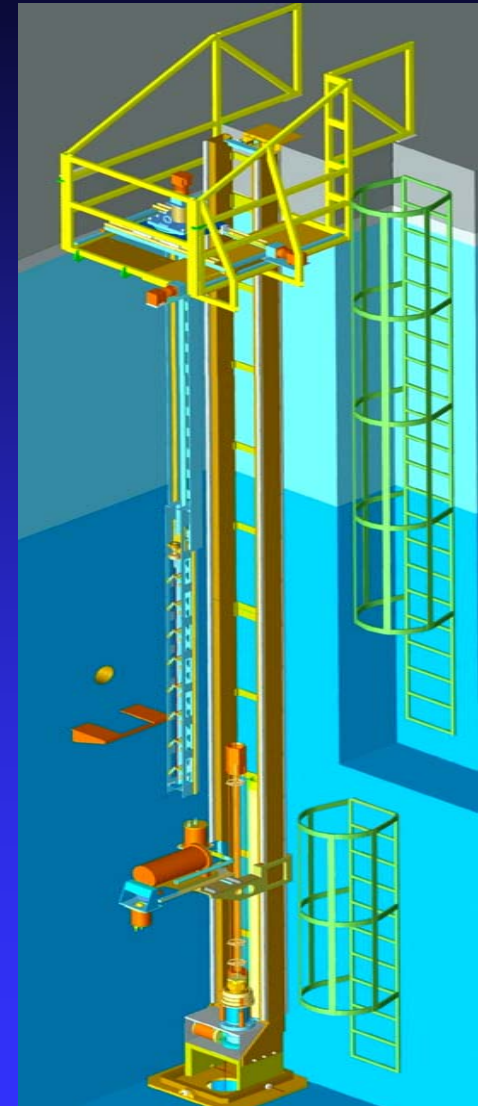



Poolside Inspection

- **35 Specialists from 14 countries attended**
- **12 Papers presented**
- **Majority of papers were from Eastern Europe and discussed VVER and RBMK fuel inspection and repair**

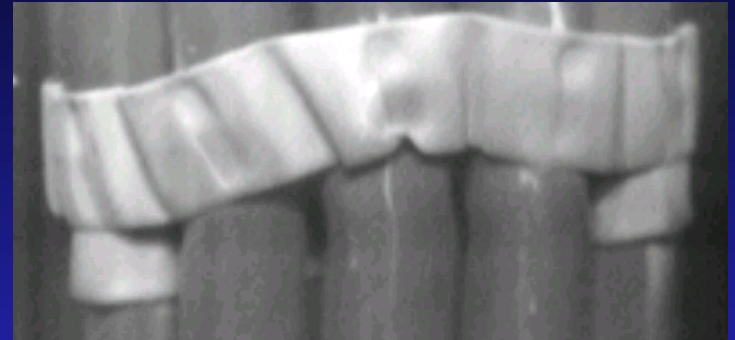



Poolside Inspection

- Papers presented from
 - Bulgaria
 - Czech Republic
 - Finland
 - Hungary
 - India
 - Korea
 - Lithuania
 - Russian Federation
 - Slovakia





Poolside Inspection

- Specialist measuring devices described

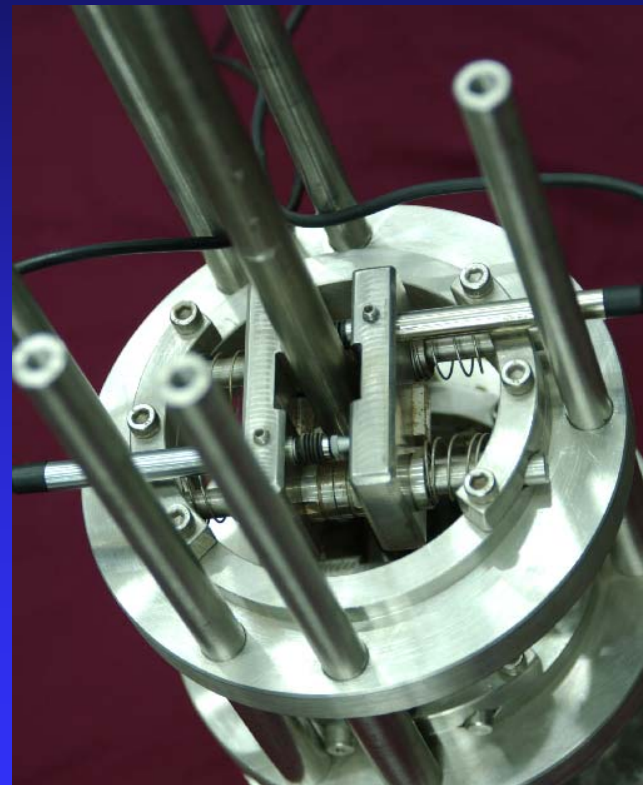



Poolside Inspection

- Detailed measurements

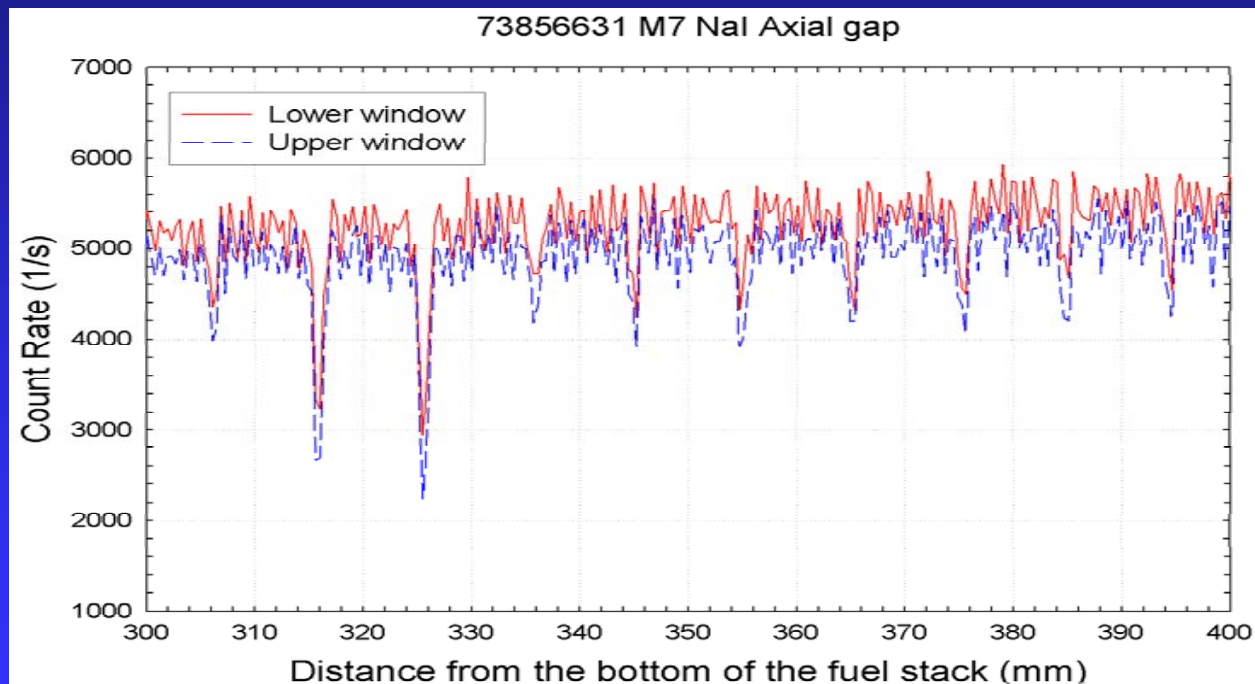



Poolside Inspection

- Fuel repair and rod replacement

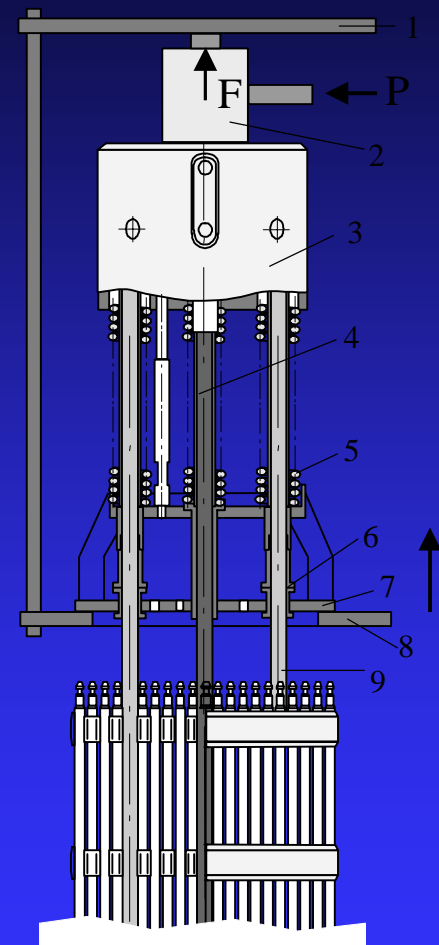
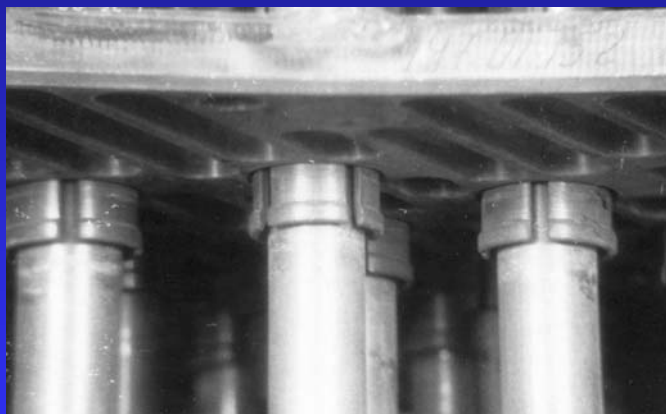



Poolside Inspection

- Research reactor fuel discussed





Poolside Inspection

- Useful discussions and experience exchanged

