



Current Status of Decommissioning Activities in Japan Atomic Energy Agency (Focusing on the Cutting Technologies)

November 3-5, 2008

International Decommissioning Network

Koichi Kitamura

**Nuclear Cycle Backend Directorate
Japan Atomic Energy Agency**

Current Status of N.P.P. Decommissioning



Fugen (JAEA)

- ATR (Heavy water reactor)
- Electrical Output: 165 MW
- Operation : March, 1978 - March, 2003
- Decommissioning : Feb., 2008 – 2028

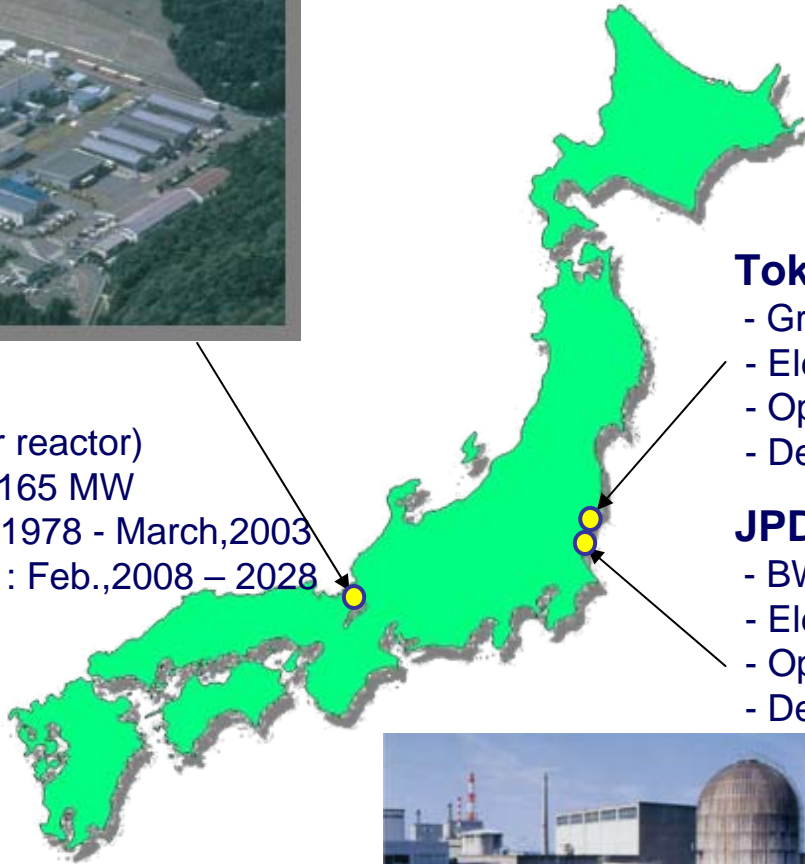

Tokai NPS (JAPCO)

- Graphite-moderated CO₂ gas-cooled reactor
- Electrical Output: 166 MW
- Operation : July, 1966 - March, 1998
- Decommissioning : December, 2001 – 2017

JPDR (former JAERI)

- BWR
- Electrical Output: 12.5 MW
- Operation : October, 1963 ~ March, 1976
- Decommissioning : May, 1986 – March, 1996



Current Status of N.P.P. Decommissioning



Fugen (JAEA)

- ATR (Heavy water reactor)
- Electrical Output: 165 MW
- Operation : March, 1978 - March, 2003
- Decommissioning : Feb., 2008 – 2028

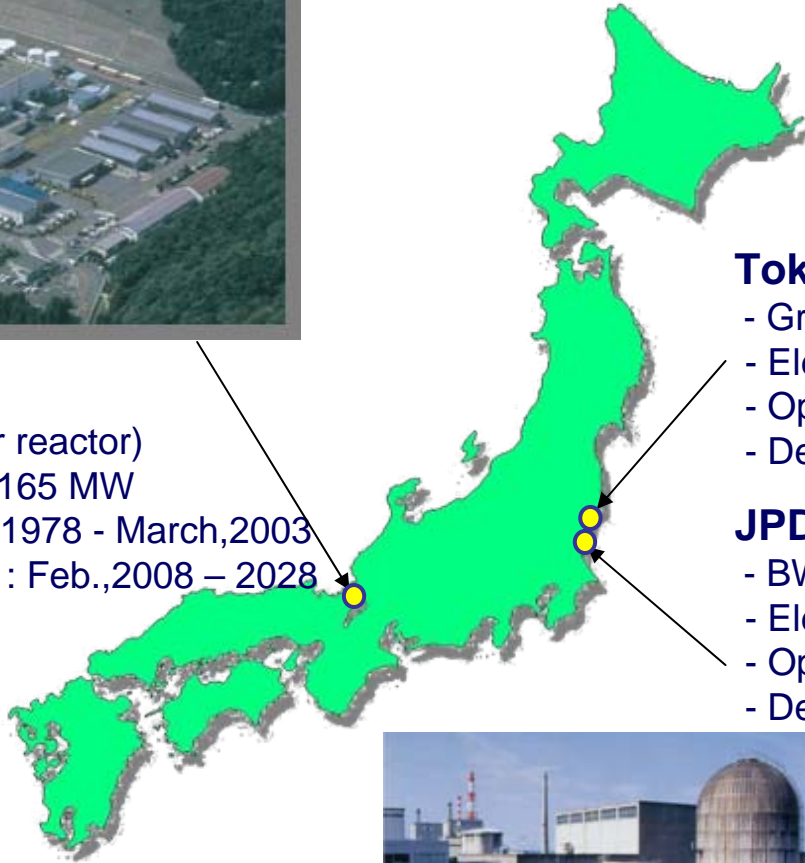

Tokai NPS (JAPCO)

- Graphite-moderated CO₂ gas-cooled reactor
- Electrical Output: 166 MW
- Operation : July, 1966 - March, 1998
- Decommissioning : December, 2001 – 2017

JPDR (former JAERI)

- BWR
- Electrical Output: 12.5 MW
- Operation : October, 1963 ~ March, 1976
- Decommissioning : May, 1986 – March, 1996



Dismantling Concept of Fugen

Transport of spent fuel and heavy water

Partial dismantlement of turbine system

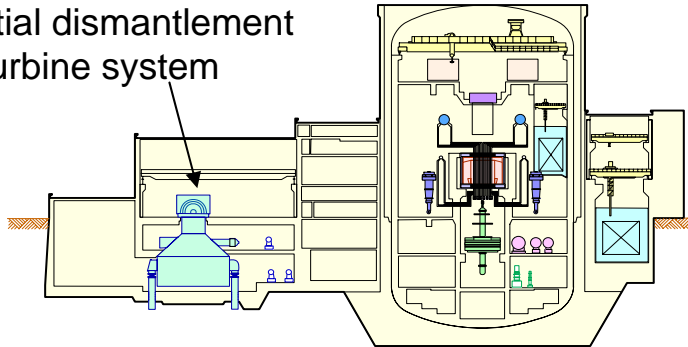

(1) Spent Fuel Transfer Period

Dismantling of components around the reactor core

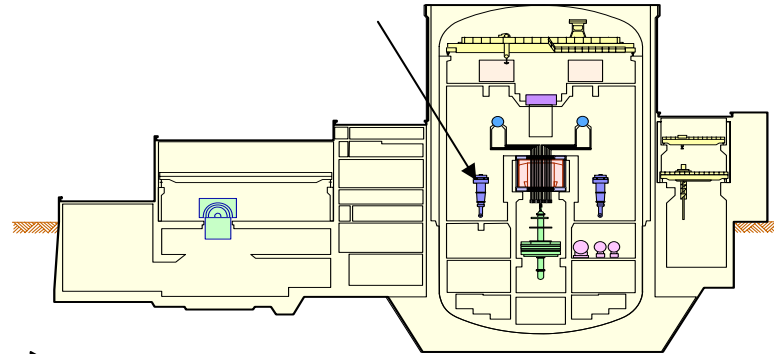

(2) Periphery Facilities Dismantling Period

Dismantling of the reactor core region

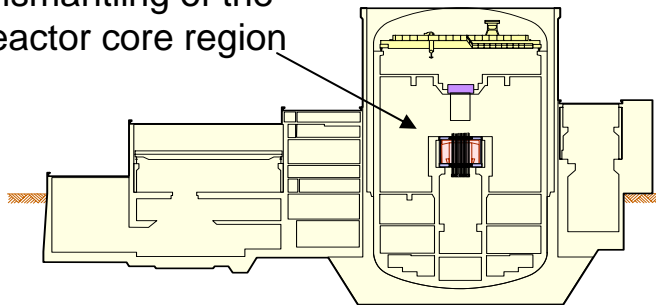

(3) Reactor dismantling period

Demolition of buildings cleaned and surveyed

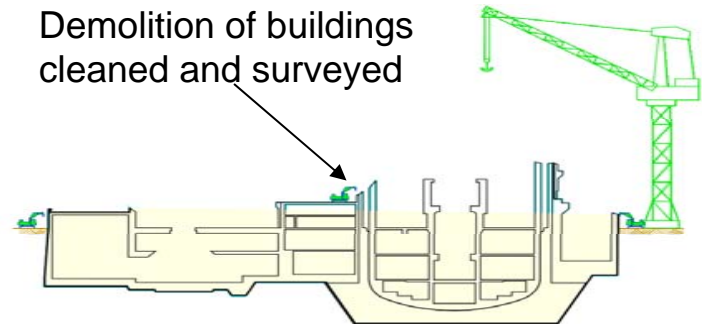

(4) Building demolition period

Dismantling Concept of Fugen

Transport of spent fuel and heavy water

Partial dismantlement of turbine system

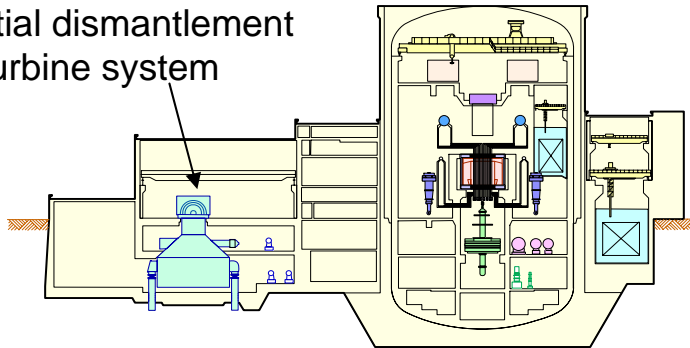

(1) Spent Fuel Transfer Period

Dismantling of components around the reactor core

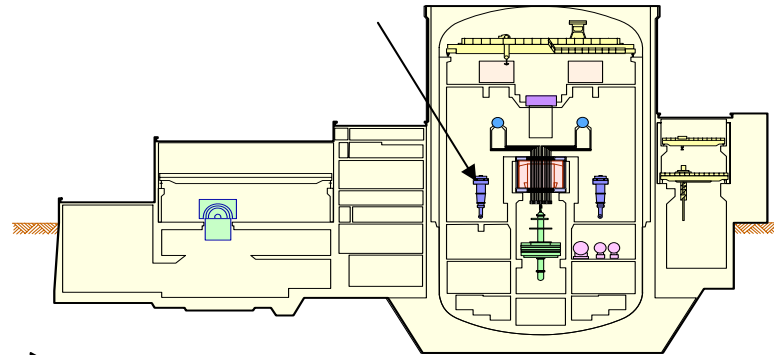

(2) Periphery Facilities Dismantling Period

Dismantling of the reactor core region

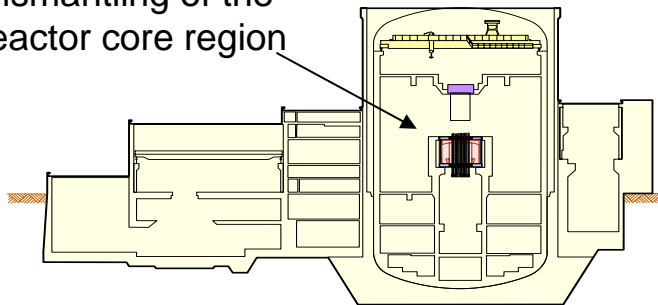

(3) Reactor dismantling period

Demolition of buildings cleaned and surveyed

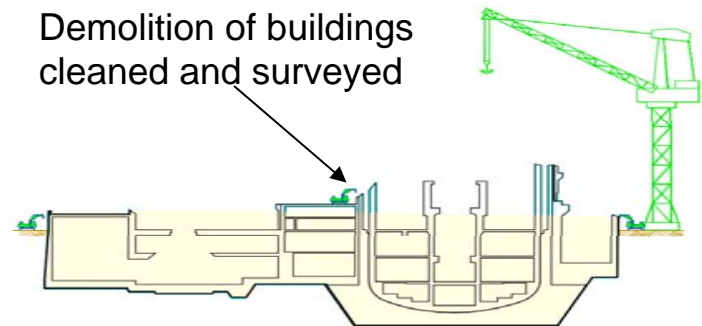

(4) Building demolition period

Example of Cutting (Dismantling of Feed Water Heater)

Cutting method of Feed Water Heater

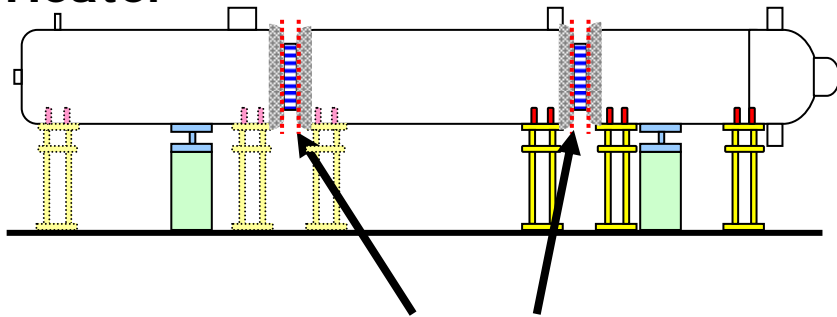

Cutting by Orbital Pipe Cutter etc.



Orbital Pipe Cutter

- Cutting rate : 5 mm/min
- Power : Compressed Air
- Weight : 110kg

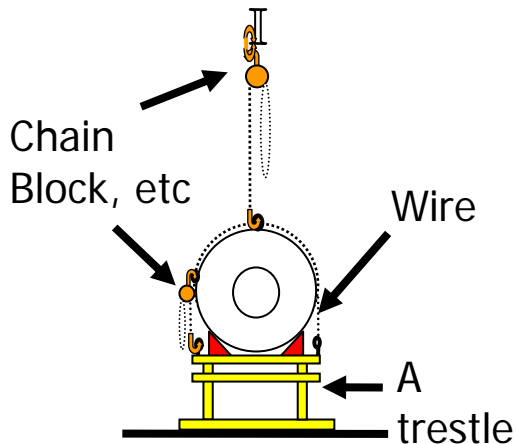

putting



Self-Propelled Gas Cutting Machine

- Cutting rate : 100-700 mm/min
- Weight : 15kg

Example of Cutting (Dismantling of Feed Water Heater)



Orbital Pipe Cutter, Self-Propelled Gas Cutter, Plasma Gas Cutter

Example of Cutting (Dismantling of Feed Water Heater)



Electrically-powered Saw Cutting

Applicability Test on Abrasive Water Jet Method for the Reactor Core Dismantling

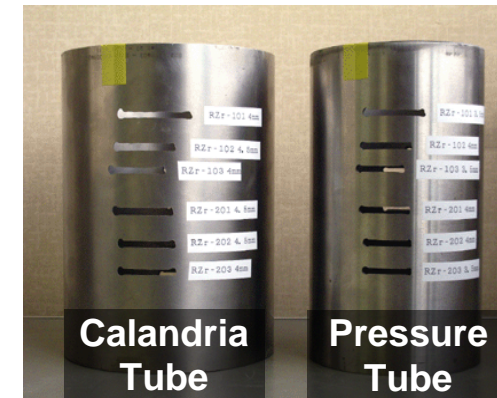
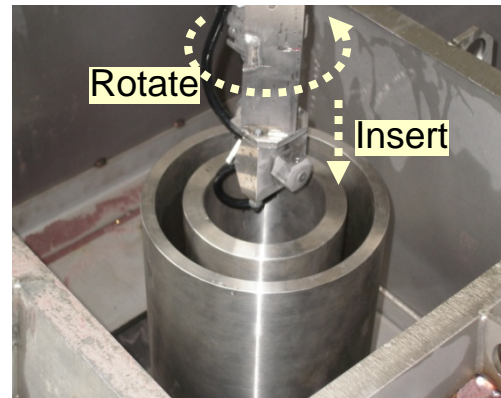
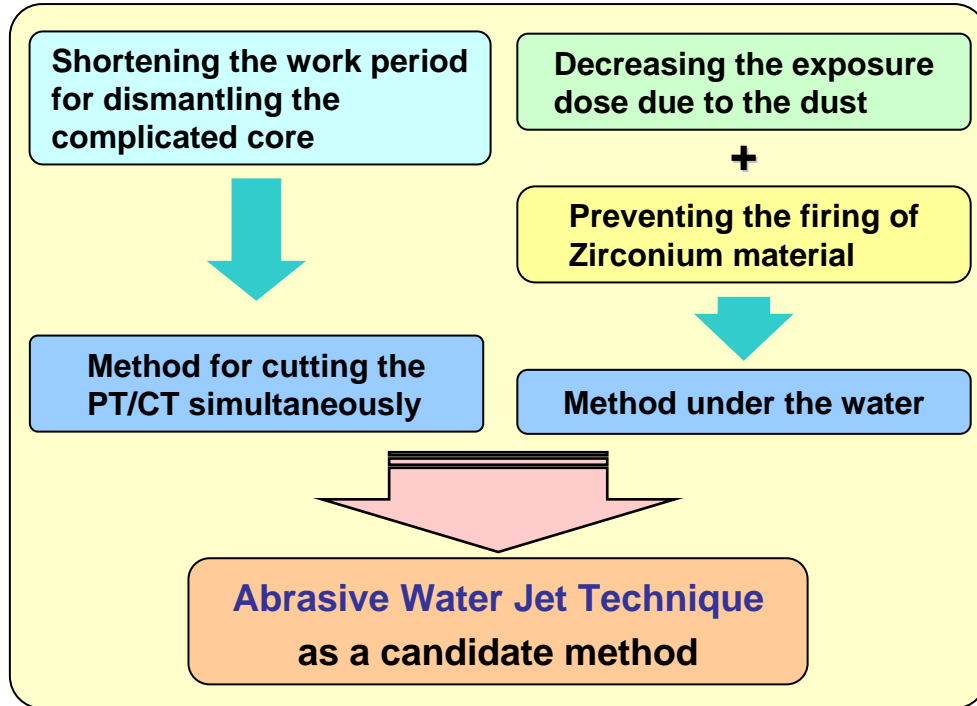
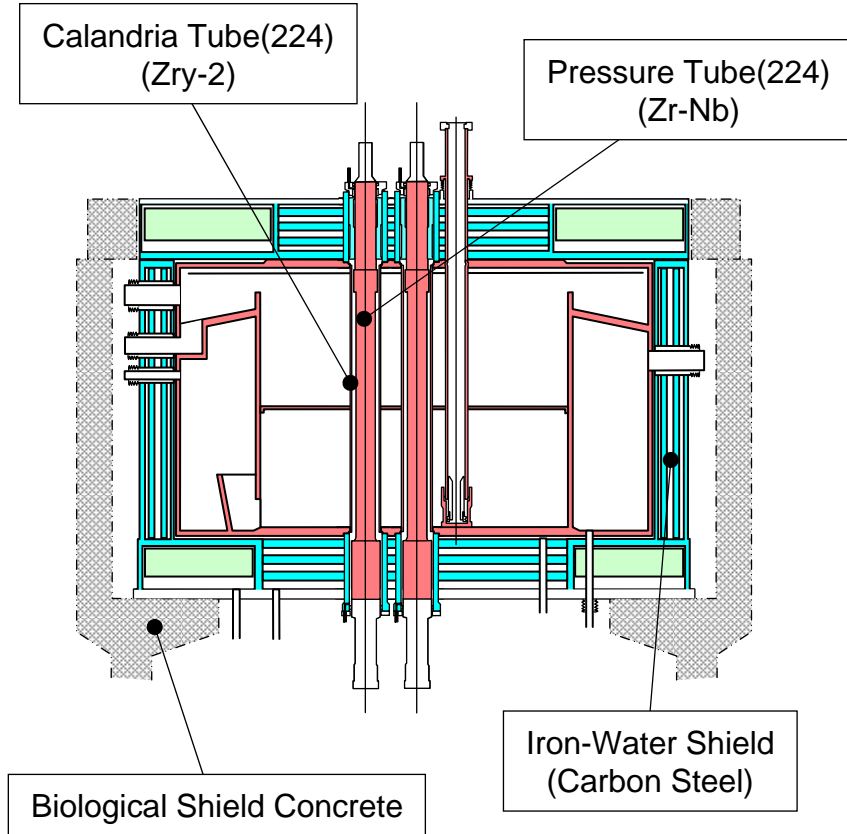

Reactor cross section

Cutting Test Status

Applicability Test on Abrasive Water Jet Method for the Reactor Core Dismantling

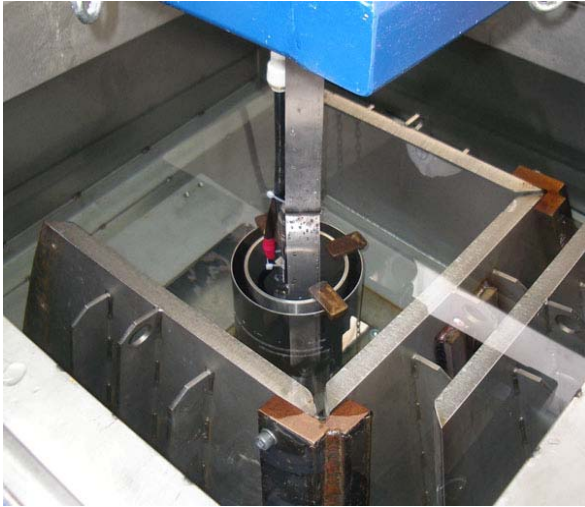

Fill a device with water



**Cutting appearance
(Cut off tubes from the inside)**

Cutting Test Status

Investigation process on dismantling method for reactor core

Operation Preparation phase Decommissioning phase

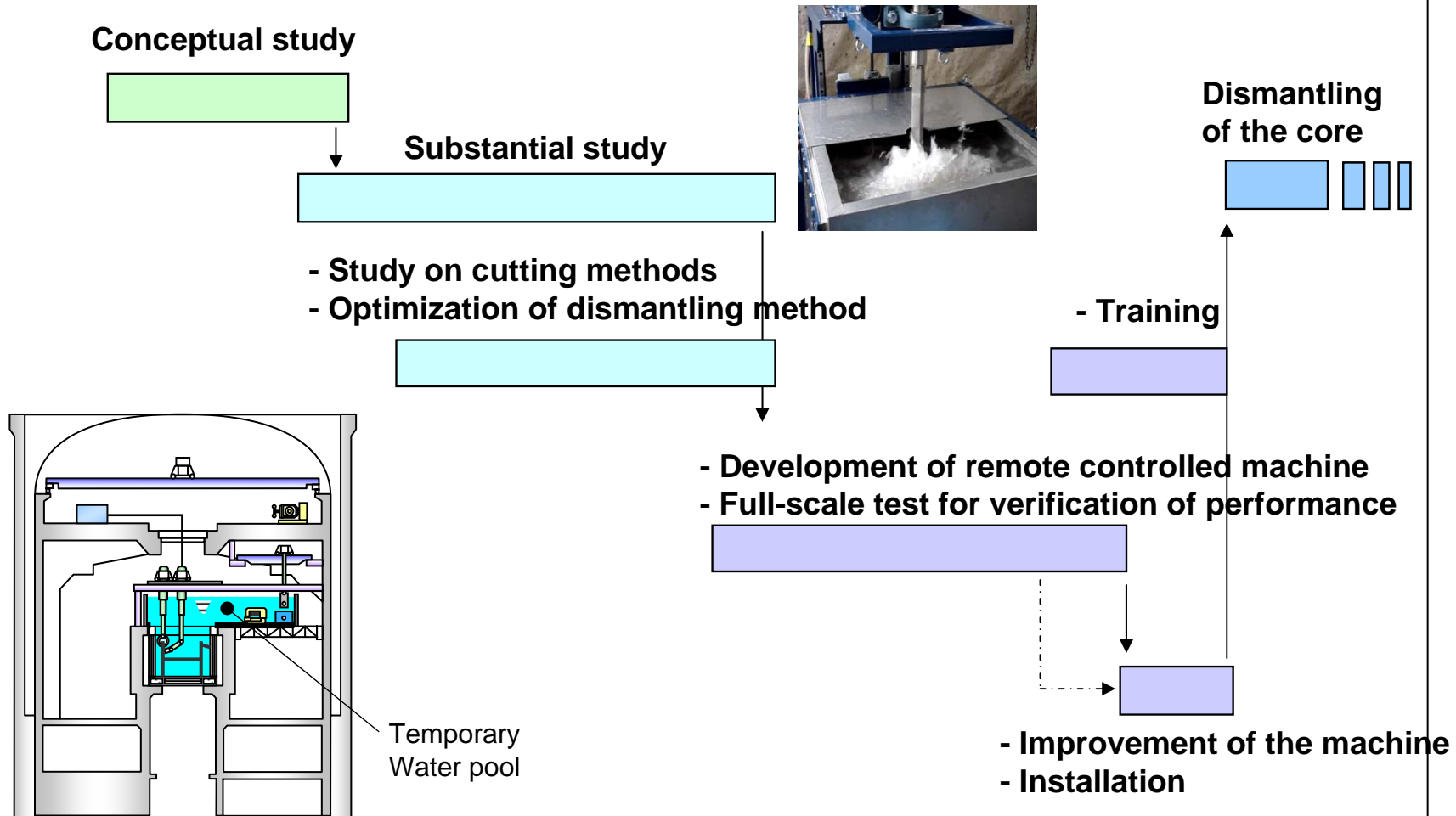

Conceptual diagram of dismantling method

Summary and future plans

- ✓ Fugen has just started Decommissioning work in this year. The dismantling of Turbine sys. has been carrying out with several cutting technologies. The knowledge and technologies of dismantling will be accumulated by these experiences.
- ✓ Abrasive Water Jet technique as one of the candidates has been studied to develop for dismantling of Fugen's reactor core. The investigation will be carried out in order to materialize the practical machine, considering with aspects of the efficiency and the reduction of secondary radioactive waste, etc.

Outline of Basic Plan for Reactor Dismantling

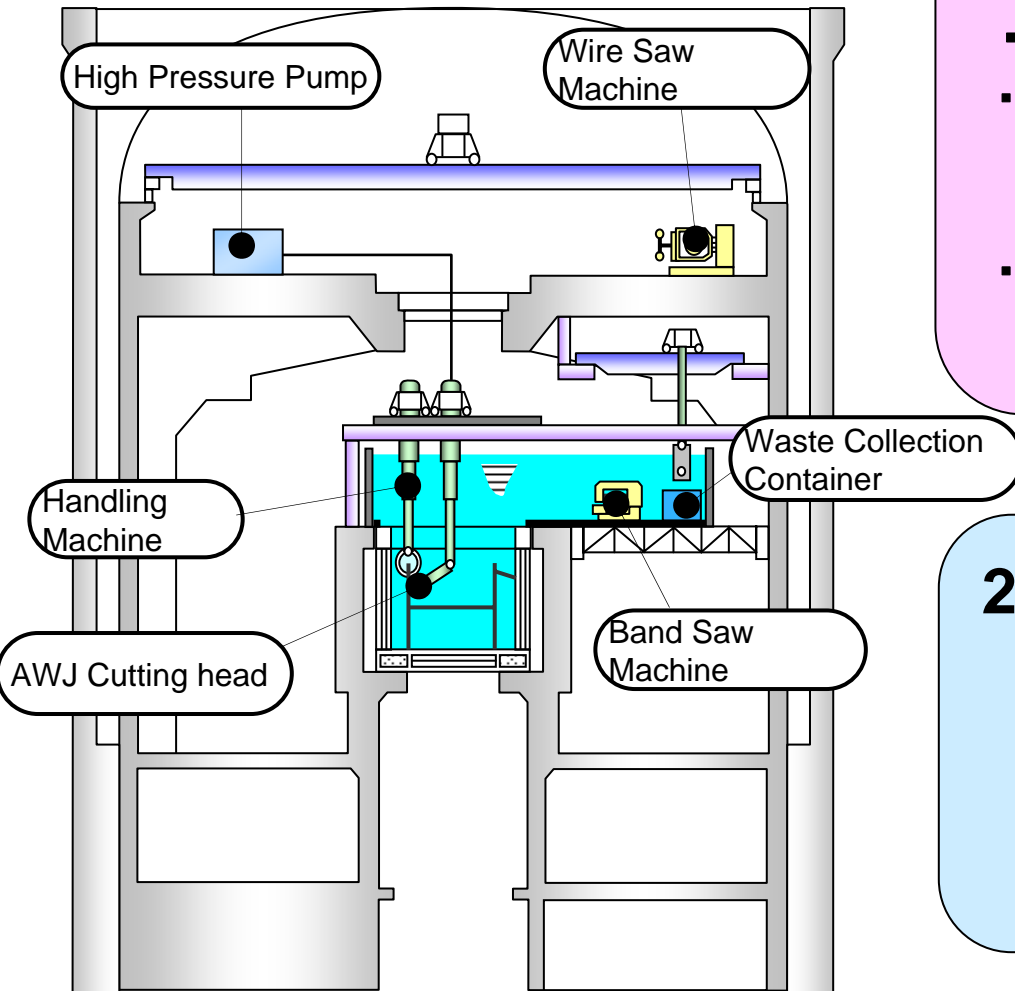

1. Basic Plan

- Lateral extension of temporary pool
- Parallel execution of work separated into primary cutting and secondary sizing
- Dismantling of P/T-C/T assembly (high radioactivity) in water

2. Supposed Cutting Method

- Plasma Arc(or Laser).....Plate
- Abrasive Water Jet.....Double Tube
- Roller Cutter.....Piping
- Wire Saw.....Concrete
- Band Saw.....Secondary Sizing

1. Study for optimizing the usage of abrasive on AWJ method

Downsized AWJ Cutting Head

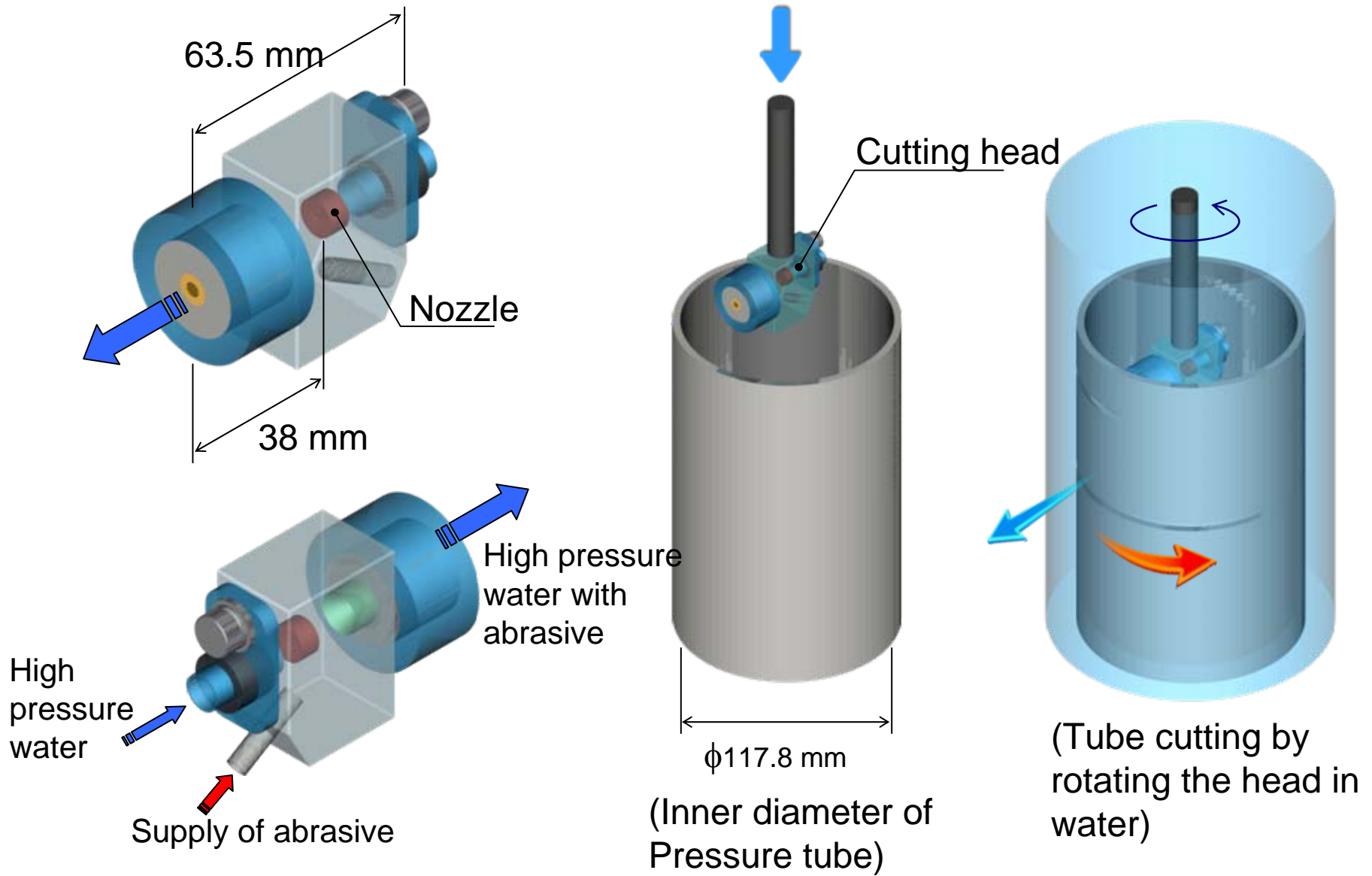

1. Study for optimizing the usage of abrasive on AWJ method

Cutting Performance Test for Double-tube by AWJ method

1. Purpose

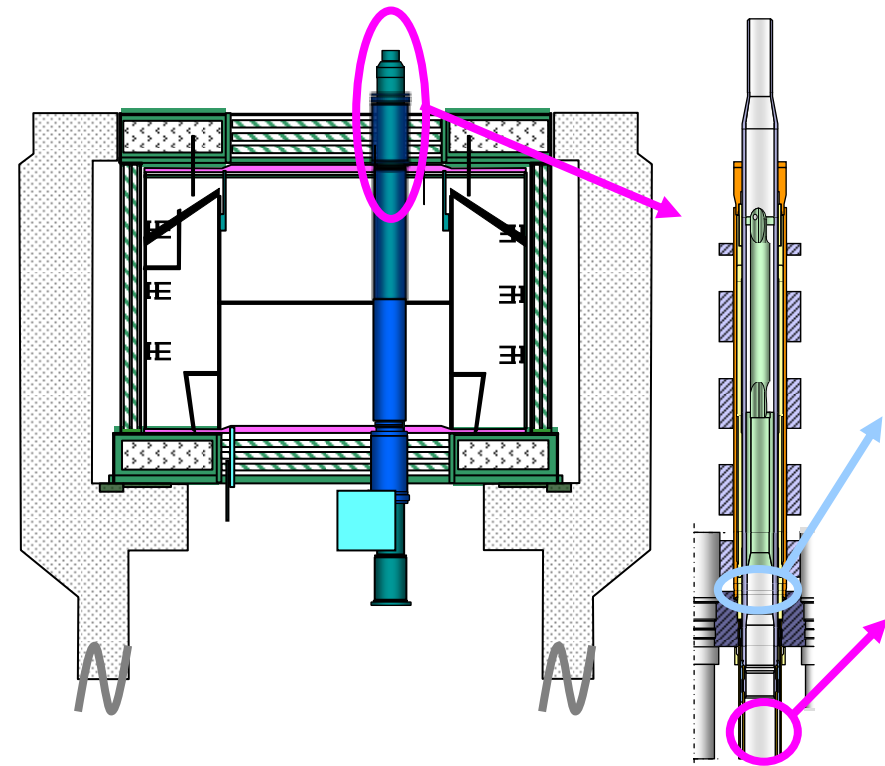

2. Double-tube models

SUS model



Pressure tube upper elongation tube (inner tube)

Material: SUS304

Thickness: 16 mm

External diameter: 127 mm

Upper iron-water shield sleeve (outer tube)

Material: SUS304

Thickness: 10 mm

Diameter: 190 mm

Zr model



Pressure tube (inner tube)

Material: Zr+2.5%Nb

Thickness: 4.3 mm

External diameter: 126.4 mm

Calandria tube (outer tube)

Material: Zircaloy-2

Thickness: 1.8 mm

External diameter: 153 mm

1. Study for optimizing the usage of abrasive on AWJ method

Relationship Between Cutting Velocity and Abrasive Supply Rate

Test condition: under water, discharge pressure 200MPa

SUS model

standoff: 7.5mm

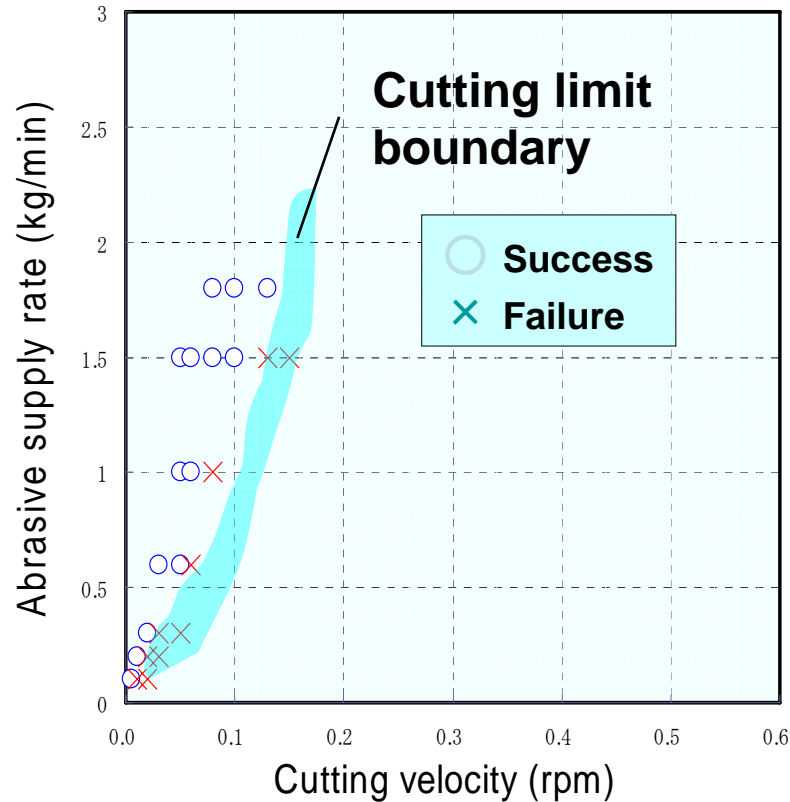

Zr model

Standoff: 18.9mm

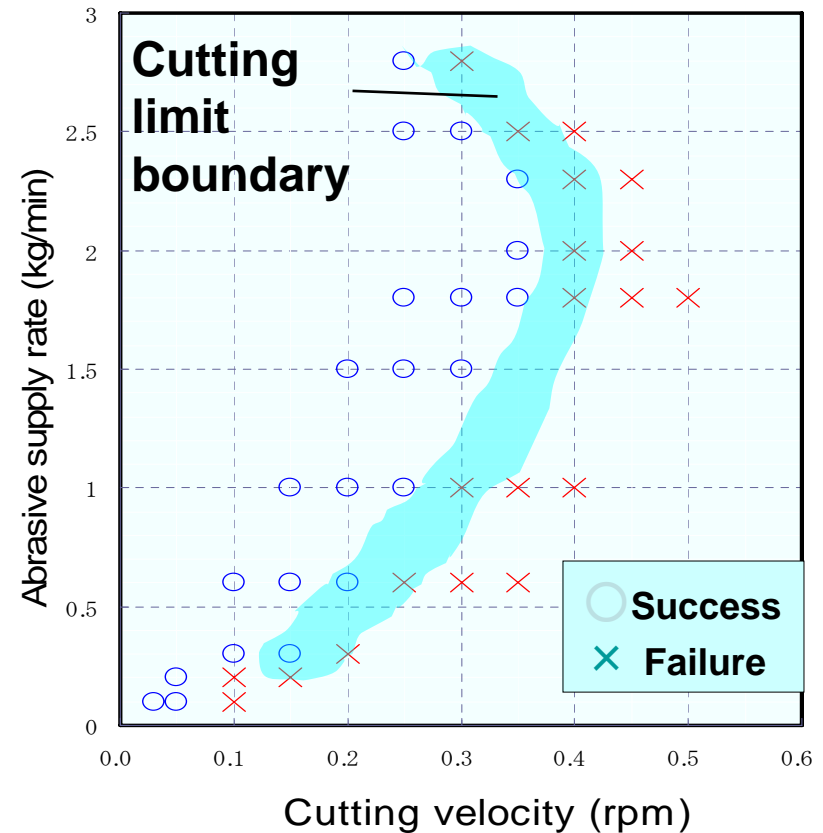

2. Study for monitoring the cutting situation under water

Study for Monitoring the Cutting Situation under Water

Purpose

The case of cutting the material used AWJ under water, the water is made cloudy by cutting grit and abrasive. So visual monitoring of the cutting condition under water with camera is difficult.

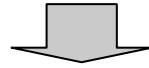

Study alternative methods to monitor the AWJ cutting condition

Outline of tests

Supposing that the cutting sound / vibration is different depending on the cutting situation (success, failure etc.), the data on cutting sound and vibration is acquired.

【 Test for measuring the cutting sound 】

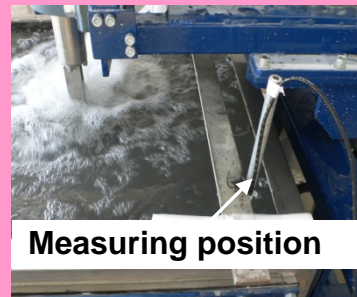
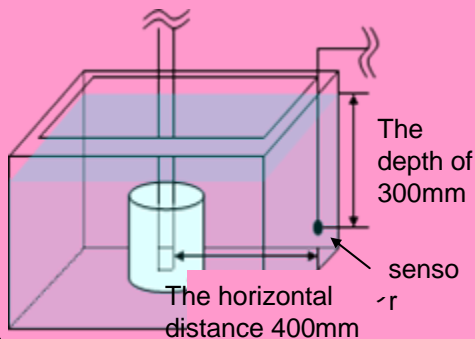

【 Test for measuring the cutting vibration 】

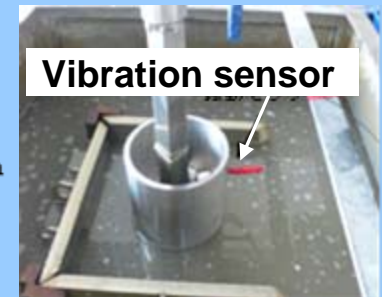
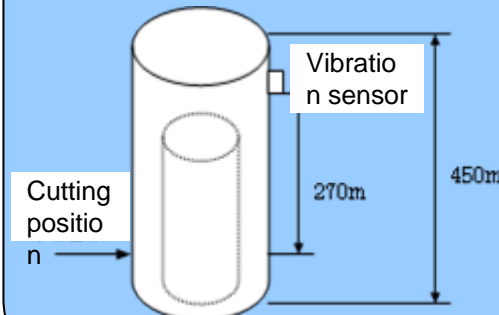

2. Study for monitoring the cutting situation under water

The result of test for measuring the cutting sound

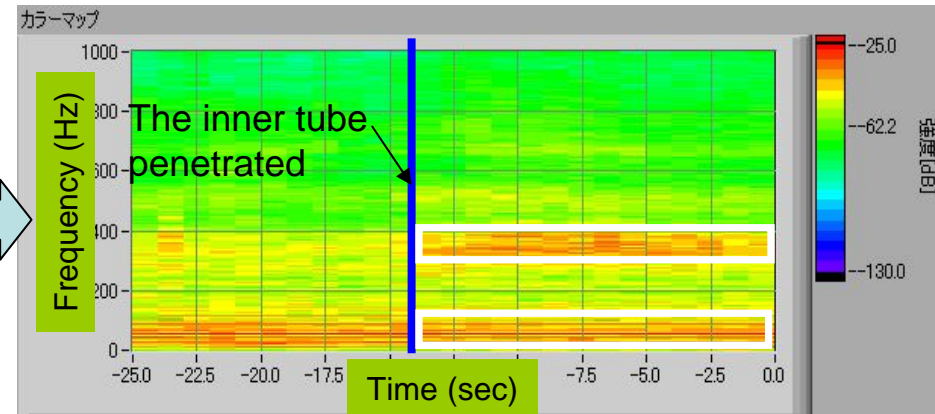
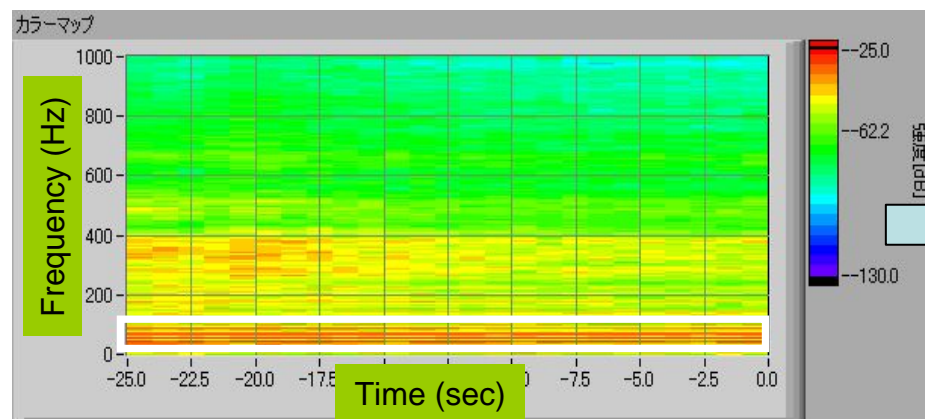

(Until the inner tube is penetrated through)

(Until the outer tube is penetrated through)

The outer tube penetrated

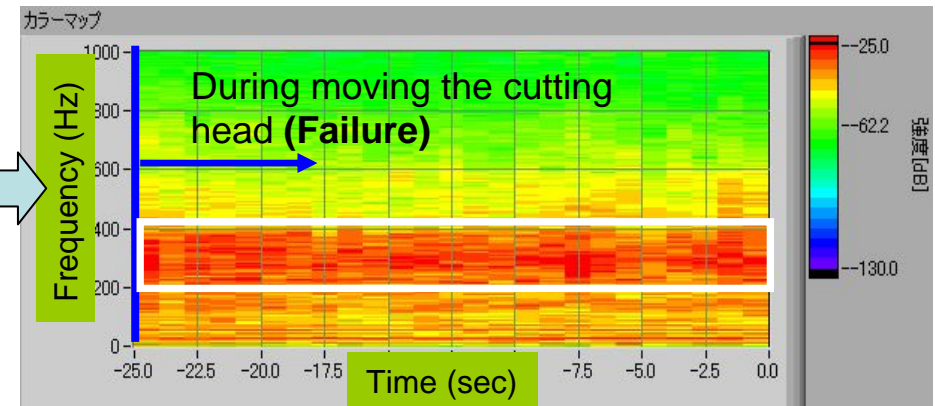
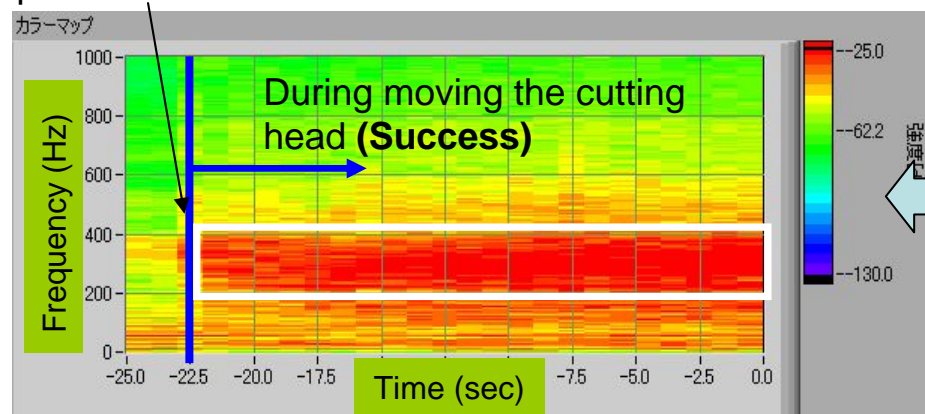

(During moving the cutting head (Success))

(During moving the cutting head (Failure))