

Project proposals for management of SNF from nuclear submarines with water-cooled reactors

V.A. Mazokin

*Research and Development Institute of Power Engineering (NIKIET)
named after N.A. Dollezhal*

The proposals for handling SNF of NS water-cooled reactors in Gremikha were elaborated in conformity with the Concept of nuclear submarine (NS) dismantling currently effective in Russia, which contains fundamental regulations pertinent to the environmental remediation of the Navy coastal technical bases and envisages, in this case, removal of spent nuclear fuel (SNF) from water-cooled reactors¹ from their territory (para. 7.4.7).

The coastal technical base (CTB) in Gremikha located in the Eastern part of the Kola Peninsula (see Figs. 1, 2), was designed and constructed for operative servicing of NS in the Northern region of Russia, as well as for receipt, temporary storage and transshipment of SNF, receipt, storage and processing of radioactive waste (RW).

The infrastructure and engineering features of the base were designed for providing refueling of the first generation NS reactors, as well as the Alpha-class and Victor-class submarines.

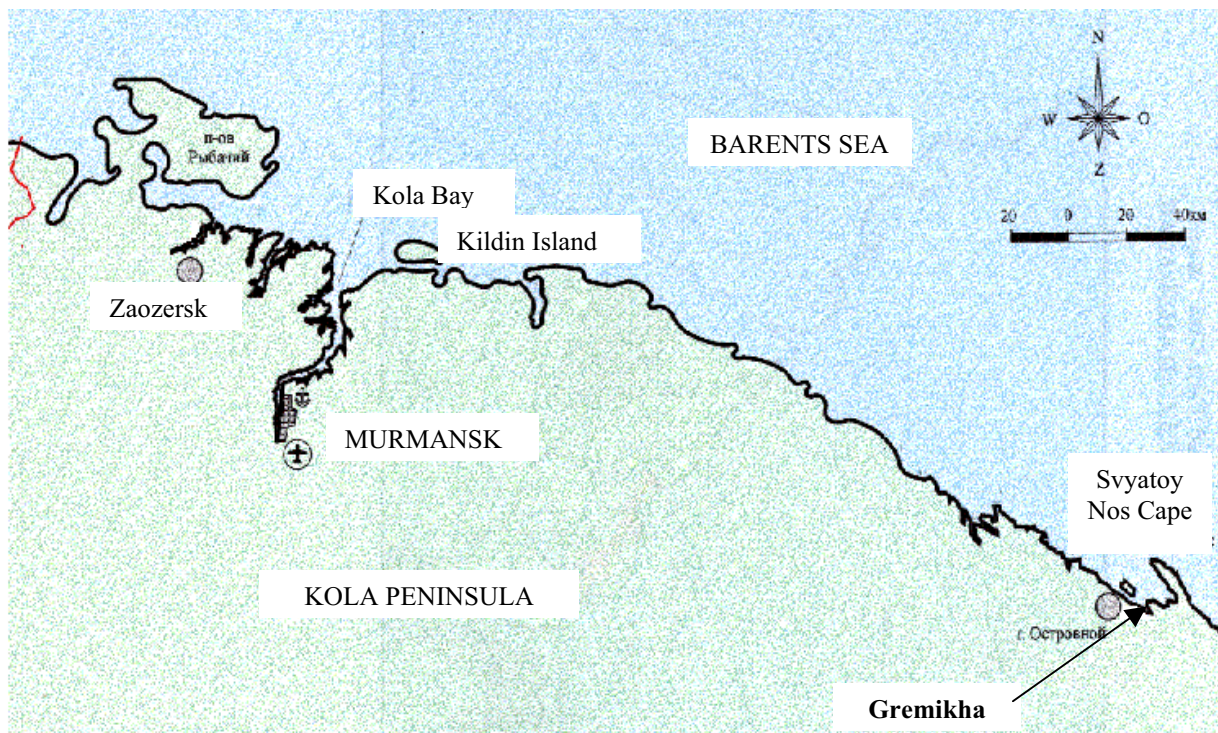

Fig. 1. Regional map

¹ Issues of management of SNF from LMC reactors are not considered in this paper, as they are covered in the papers by Mr. V.A. Shishkin and Mr. V.N. Pantelev.

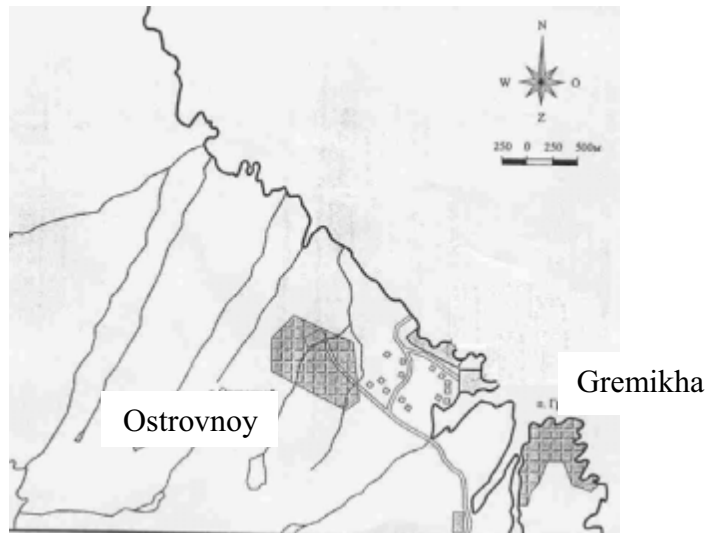

Fig. 2. Zonal plan

SNF was unloaded from the reactors when a NS was placed on a solid foundation in the dock SD-10. SNF unloaded from water-cooled reactors was stored in a special SNF storage facility (Building 1) built near the dock (see Fig. 3).

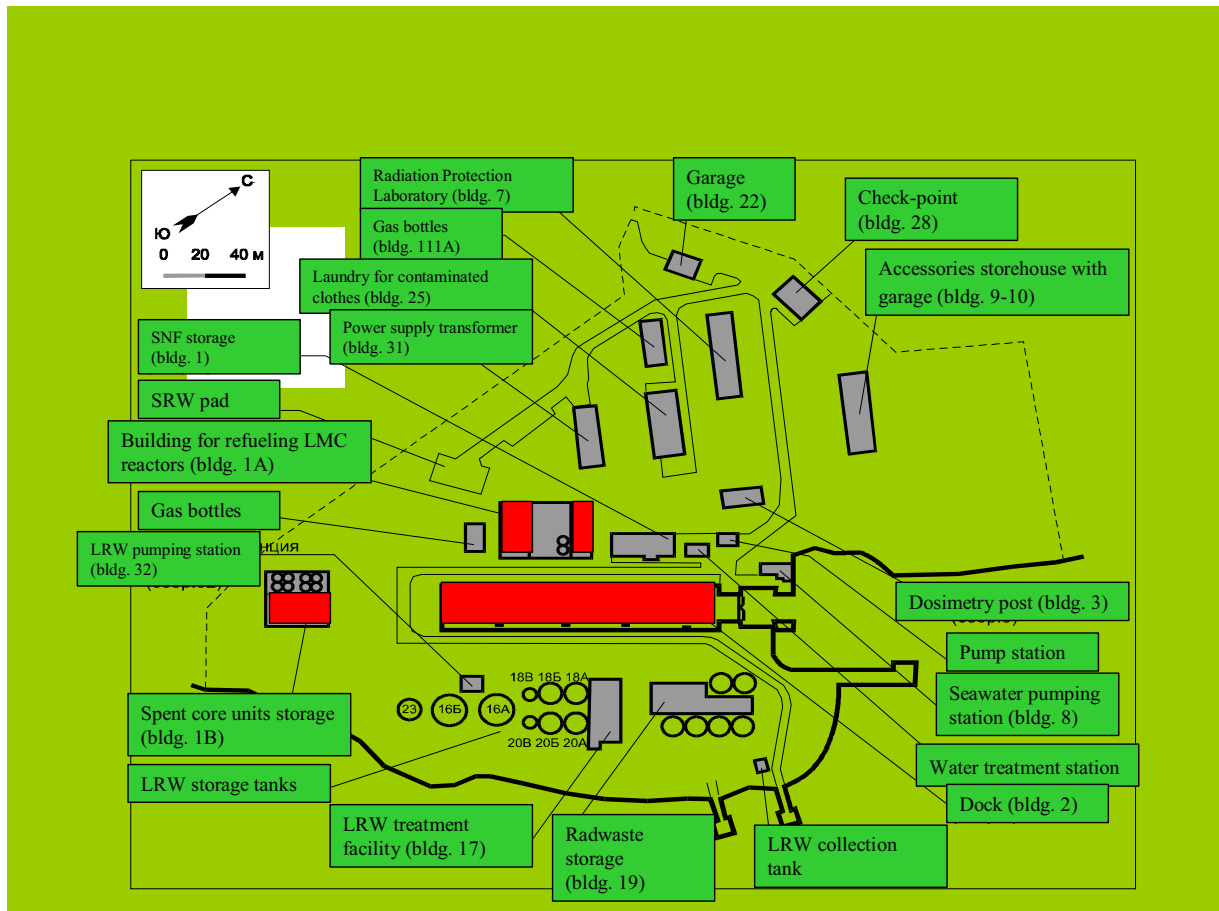

Fig. 3. Layout of the buildings and structures on the territory of the base in Gremikha

SNF was transferred to Building 1 by a crane with the use of PU-2 fuel-handling device from a NS reactor directly or from on-board storage chambers of a floating technical base (hereinafter FTB) of design 326 (or 326m) placed in the dock SD-10.

Building 1 is made up by four autonomous ferroconcrete pools (concrete basins, each of 68 m³ holding capacity), lined with carbon steel, and a common process hall. Each pool is covered by flooring made of corrugated iron with transport passageways. Spent fuel assemblies (SFA) were stored in the pools in water directly, as no arrangement within canisters was envisaged at that time. Process operations aimed at SFA transfer to Building 1 were performed by a dockside crane with load-carrying capacity 10 tons, which was installed between Building 1 and dock SD-10.

Building 1 was operated since 1962 to 1986 until water leakage from pool No. 1 was detected. After that SFA from all the pools were unloaded, except for 95 defective SFA. An attempt to withdraw them from pool No. 1 using routine technological means at that time failed. Later (in May, 1999) the SFA were unloaded from pool No. 2 into 16 canisters of type 22 (15 canisters hosting 7 SFA and 1 canister with one SFA) and in this state they were arranged for temporary storage in Building 1, which will be discussed later.

The undamaged fuel assemblies (SFA) unloaded from the pools were packed in type 22 canisters, some of them were then arranged within type 11 shipping casks and removed from the site territory (either for reprocessing at Mayak plant or to the Andreeva Bay for transfer to storage in dry storage facilities). No new storage facility for SNF was constructed at Gremikha base instead of decommissioned Building 1. According to preliminary data not all of undamaged SNF unloaded from the pools in Building 1 was removed from the Gremikha base territory. On the open pad for SRW storage there are several type 11 casks (4 pieces according to preliminary data), in all probability containing SNF. Type 11 cask is designed for temporary storage and transportation of one type 22 canister in compliance with regulatory requirements for nuclear and radiation safety. Seven SFA from water-cooled and water-moderated NS reactors could have been arranged inside the canister within the spacer grid.

Designs of type 11 cask and type 22 canister are shown in Figs. 4 and 5.

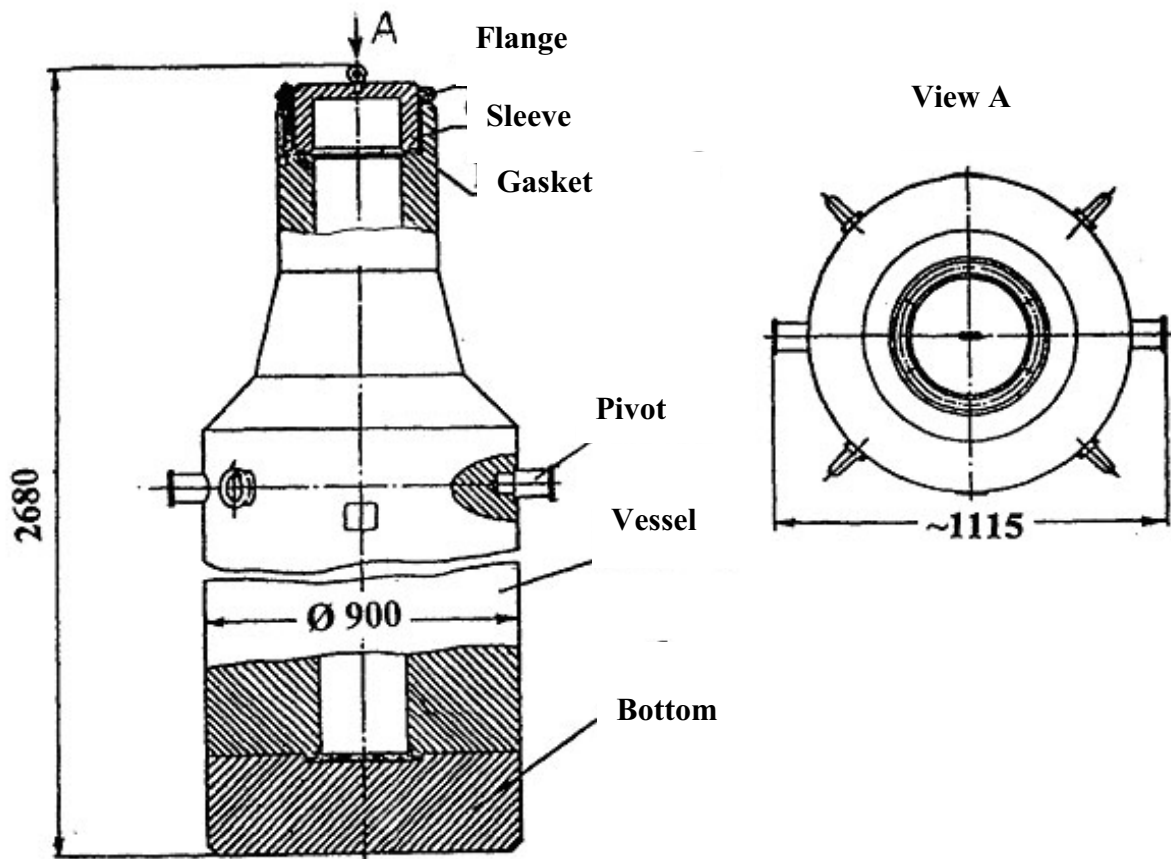

Cask material – steel 20
 Cask weight – 8850 kg

Fig. 4. Type 11 protective cask

SNF unloaded from NS reactors in other locations of the region was also delivered to Gremikha coastal base for temporary storage. Specifically, SNF from Severodvinsk, unloaded from NS reactors at Zvezdochka shipyard was brought there. The fuel was placed into type 6 protective casks with a spacer grid, which could host seven SFA without canisters. Unfortunately, no design documentation on type 6 casks is available at present and data pertinent to their weight and dimension parameters, structure of slinging units can be obtained solely by examination of the casks mentioned. Nowadays, the casks with SNF are arranged on the open pad, intended for SRW storage. According to preliminary data the pad hosts 116 casks with SNF (112 pieces of type 6 casks and 4 pieces of type 11 casks).

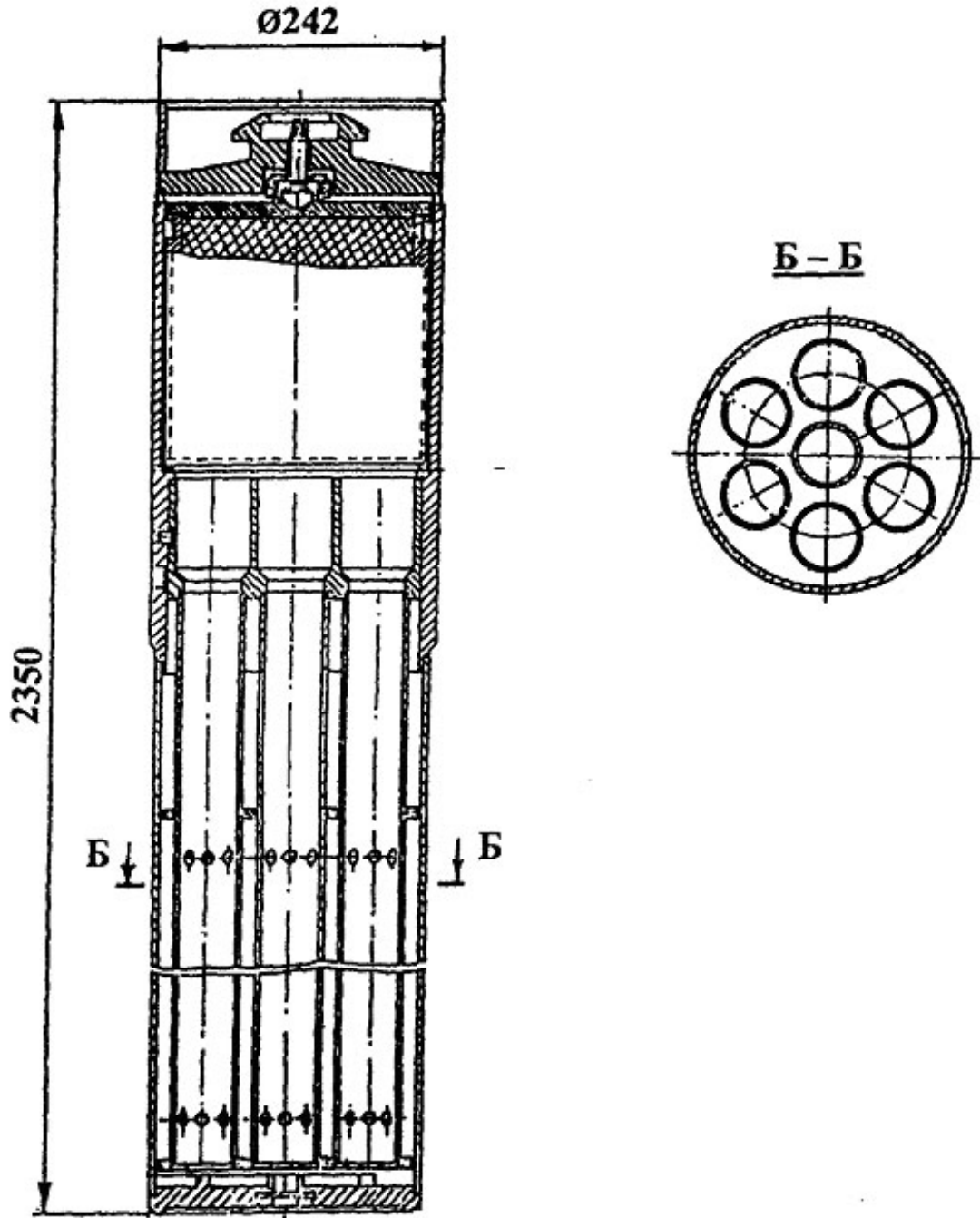

Weight– 265 kg
 Material – stainless steel

Fig. 5. Type 22 canister

Besides the open pad for SRW temporary storage, a portion of SNF in type 22 canisters is stored in cavities (sumps) near the pools of Building 1 (see Fig. 6). There were arranged 16 type 22 canisters hosting 106 damaged SFA unloaded (as has been mentioned

above) from pool No. 2 in May, 1999. It is worth noting that type 22 canisters are designed for SFA isolation from the environment and they do not feature radiation-shielding functions in reference to SFA ionizing radiation.

In the past SNF was removed from the Gremikha base to a railway terminal by sea on board the FTB of 326 design (or 326m), which was preliminarily placed in dock SD-10 for accepting SFA and placing them either into canisters (FTB 326) or into cases (FTB 326m).

At present this practice of SNF removal can not be used, as its transportation on board the FTB 326m is forbidden due to exhaustion of the FTB design life, while new FTB of 2020 design and FTB belonging to Murmansk Shipping Company (Imandra and Lotta), having certificates for SNF transportation, can not be placed in dock SD-10 because of their larger overall dimensions. No other ways for SNF removal from the base were devised.

The greatest challenges arise from handling the SNF stored on the open pad within type 6 casks. First of all, elevated levels of radiation on the pad for storage of containers and casks with SNF (near entrance to SRW storage pad gamma radiation levels vary from 0.3 to 3 mSv/h) restrict access to the casks for their technical inspection and ascertaining conditions for their movement and opening for inventory taking of their contents. Specific features of SFA arrangement within type 6 cask volume (without canisters) will necessitate the development of special technologies for their extraction from the casks, examination and package (into type 22 canisters, for instance) using robotic systems, control systems and personnel safety assurance systems.

Earlier no survey of the casks with SNF have been conducted, as the relevant conditions for safe activities were lacking. A special compartment (a bay) shall be prepared and equipped within one of the available structures at the base, in Building 1, for instance (central hall) or in Building 9-10 (engineered facilities store), its area 280 m², equipped with a bridge crane of 10 tonne carrying capacity. This compartment is to be used for support of the cask inventory taking and SFA re-packaging into new canisters, as well as for temporary storage of casks with SNF. A station for SNF unloading from casks and a station of SFA unloading (loading) from the canisters (into the canisters) are to be envisaged within the compartment too.

The compartment chosen shall be equipped with special ventilation and special sewage system, decontamination center, engineering barriers for personnel protection and radiation monitoring system, TV observation and control devices, necessary technological rigs, as well as appropriate energy media (electric power, water, air, inert gases).

For choosing and substantiating the optimal process of handling the casks and SNF the comparative feasibility study of possible options for temporary isolation of the casks and canisters with SNF shall be made; cask inventory point and handling scheme for the casks removal from the open pad to the point arranged shall be set up; technologies for dismantling the casks, package and preparation of SNF for removal shall be developed; technological equipment and means for control over nuclear- and radiation-hazardous activities shall be introduced.

Design documentation will be developed on the option chosen, the list of required equipment and technological rigs will be compiled, and safety of the technical approaches and processes chosen will be substantiated, the implementation period and the relevant costs being refined.

From the existing equipment the assembly 02 OK-300PB and KB-651 in-base transport cask (see Fig. 7) can be used for safe SNF handling, for SFA removal and arrangement in the canisters, for transportation and placing of the canisters into casks.

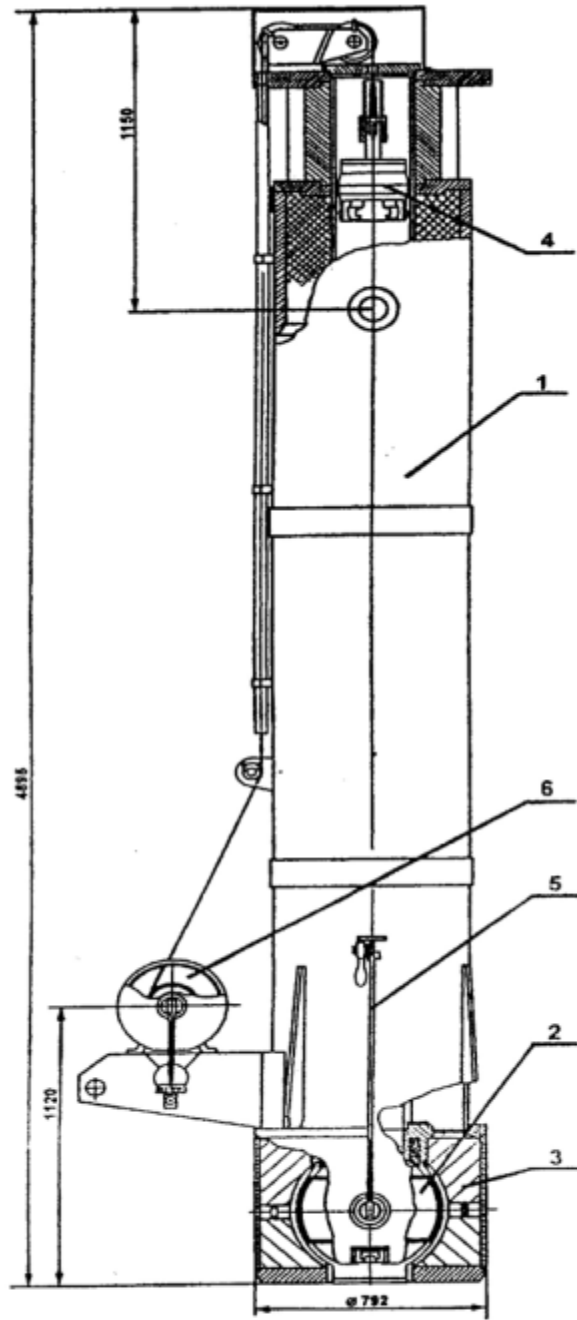

1- body; 2- gate (stopper); 3- foundation; 4- clutch; 5- lever; 6- hoist

Fig. 7. KB-651 in-situ container

As it has been mentioned above, changing of storage conditions for casks with SNF by preventing effect of atmospheric precipitation is a top-priority measure. It can be attained either by constructing an overhead cover above the SRW storage pad or by arranging the casks within a compartment. In our opinion, the second option is advisable, as construction of a cover with a roofing features or any other structure has the following shortcomings:

- the activities on the pad are impeded by significant radiation background, availability of rock in the foundation and cliffs on the two sides of the pad. Besides, strong wind loads (wind speed up to 20-25 m/s, which may reach 30 m/s) do not permit construction of a light-weight cover;
- any light-weight cover above the pad will make very difficult the handling operations involving the casks and containers, which are planned to be conducted by a truck crane. Otherwise, the structure above the pad shall be fitted out with a 10 t carrying capacity bridge crane, which will complicate further the construction of the cover.

Development and substantiation of a handling operations flowsheet for SNF removal from the base territory using dock SD-10, can be stated as one of the most urgent tasks in handling SNF at the Gremikha base, as the base has no other facilities for SNF transfer from the coast to a sea ship.

In our opinion, the following option, which seems the most feasible, shall be considered:

- one of FTB of 326m design (PM-124), which is used now for unloading and transshipment of SNF from the reactors of dismantled NS on board the FTB of 2020 design in the water area of Zvezdochka shipyard (Severodvinsk), is to be repaired (including repair in the dock) and the permission is to be obtained for using the PM-124 for receipt of canisters with SNF in dock SD-10 and their transfer on board the FTB of 2020 design in the water area of Gremikha;
- the PM-124 is to be towed (after repair) to the Gremikha base water area;
- canisters with SNF are to be prepared (in the newly arranged compartment or bay) for shipment;
- the PM-124 FTB is to be placed in dock SD-10 and it is to be prepared for receipt of canisters with SNF;
- using the SD-10 bridge crane and the KB-651 base cask the canisters with SNF are to be transferred to the PM-124 storage place (the PM-124 storage place holding capacity is for 80 canisters);
- the FTB 2020 (either Lotta or Imandra FTB) is to be deployed in the base water area near the SD-10;
- the PM-124 is to be moved out from dock SD-10 and moored to board of the FTB 2020;
- the canisters with SNF are to be transshipped by the FTB 2020 devices from the PM-124 storage place on board the FTB 2020;
- the rest 36 canisters containing SNF (including 16 ones from Building 1) are to be transferred on board the FTB 2020 in the same manner;
- the canisters containing SNF are to be shipped to Atomflot terminal, packed in the TK-18 (TK-108/1) type transport casks and transported to the Mayak plant.

It seems reasonable to consider the option of using a stationary pier located in the base water area. In that case, the handling operations flowsheet of SNF removal can look as follows. The FTB 2020 (or “Lotta” FTB) will be moored near the stationary pier. The canisters containing SNF prepared for transportation using a special vehicle within the KB-651 base cask will be delivered to the stationary pier and transshipped on board the FTB, which will deliver them to Atomflot terminal. The option implementation necessitates survey of the stationary pier and ascertaining the potentiality of its use for SNF transshipment, as well as the choice of transport-hoisting devices for handling the KB-651 type cask and outlining the route of its transportation over the base territory to the stationary pier.

Development of design and process documentation, safety analysis and environmental assessment of the proposed activities, as well as development and manufacture (if required) of the relevant hardware for SNF handling operations, will be necessary for assessment and selection of the option of SNF handling at the site and its removal.

At the moment it seems impossible to make even a qualitative analysis of options for handling PWR-type SNF at the Gremikha base, due to lack of the required initial data on the state of SNF packages, state of the structures and radiation situation in the places of possible operations.

As a first urgent measure for initiation of the full scale activities on remediation of the facilities at the Gremikha site, including preparatory work for handling the SNF of PWR reactors, it is necessary to establish conditions for safe performance of the radiation hazardous activities and normal live conditions for the personnel (operation of the radiation check point, radiation safety service, radiation dose monitoring, individual protection of the personnel). After these conditions are established it is necessary to conduct detailed radiation survey of the places where the SNF casks are stored (SRW pad and inside Building No.1). Actual data on radiation level in the areas where the work is to be performed, will be available as a result of this survey. This will make possible to develop necessary measures to protect the personnel working in the areas of the SNF casks location, including survey of the pivots condition, collection of data for development of the cask transportation technique.

At the first phase of activities on SNF management of PWR-type it is necessary to transfer casks from the open pad into one of the buildings available on the site. The following preparatory measures are to be implemented for this work:

- selection and preparation of the building for temporary cask storage (as it is mentioned above, Building No.10 could be used for this purpose). It is reasonable to set up a special bay in this building for opening the casks and inventory of their content, bay for SNF unloading from the casks and from the canisters and placement of SFAs into new canisters;
- development of technique and transport handling scheme for transfer of casks with SNF on the site territory to the building prepared for storage;
- transfer of the SNF casks from the open pad and from the Building No.1 into the prepared building.

Completion of the first phase will provide further safe storage of SNF of the PWR-type at the Gremikha site until its removal from the site to reprocessing has been initiated.

At the second phase it is necessary to perform development of design for management of SNF of PWR-type at the Gremikha site, conduct its review and develop detailed design and engineering documentation. The design should cover engineering equipment of the facility (section) for conducting lifting and transport operations with the SNF casks, with the in situ casks of KB-650 type, establishing the bay for unloading the canisters from the casks, removal of SNF from the canisters and installation of SNF into new canisters. At the third phase which is to follow the following activities are to be performed:

- inventory of casks and canisters with SNF;
- inspection and packaging of SNF;
- preparation of SNF for removal from the site.

Proposals for general work schedule are provided in Table 1.

Table 1

Phase	Activities	Implementation period (year)			
		2004	2005	2006	2007
1	Transfer of casks from the open pad to the prepared building				
2	Comparative feasibility studies for choosing the optimal process for the casks and SNF handling, including options for SNF removal				
3	Development of design and process documentation on the option chosen, peer review. Safety substantiation of the approved processes				
4	Development of detailed design documentation, preparation of infrastructure and technological rigs for SNF handling				
5	Inventory taking of the casks and canisters with SNF, their inspection, SNF package and preparation for shipment to the Mayak plant				

Table 2 contains the approximate assessments of the costs by phases and by the project as such obtained by expert judgments. The project cost will be refined during feasibility studies of the options and development of detailed design and operation documentation.

Table 2

Phase	Activities	Approximate costs, \$ million
1	Transfer of casks from the open pad to the prepared building	Cost of this phase is to be included in the design of the SRW management and remediation of the site
2	Comparative feasibility studies for choosing the optimal process for the casks and SNF handling, including options for SNF removal	1.7
3	Development of design and process documentation on the option chosen, peer review. Safety substantiation of the approved processes	3.5
4	Development of detailed design documentation, preparation of infrastructure and technological rigs for SNF handling	20.0
5	Inventory taking of the casks and canisters with SNF, their inspection, SNF package and preparation for shipment to the Mayak plant	36.0
	TOTAL	61.2

During development and implementation of the given project wide areas of cooperation between Russian and Western companies and organizations are available. These could be specific techniques, engineering equipment and components of different process and monitoring systems.

Handling of casks after SNF discharge is not discussed in this project. According to own position we believe that the casks should be treated as a large-scale solid radioactive waste.