

**Neutronics calculation Study for Conceptual Design
of the Fixed Bed Nuclear Reactor (FBNR)**

Ha Van Thong
Center for Nuclear Energy, Institute for Nuclear Science
and Technology
Hanoi, Vietnam
hvthong@mail.vaec.gov.vn

1. Introduction

This is a report on the work performed at the Institute for Nuclear Science and Technology in Vietnam, and under the IAEA Research Contract No. 12965/R1-RBF. The report presents the results of neutronics study for conceptual design of the Fixed Bed Nuclear Reactor (FBNR), which is designed by Prof. Dr. Fahang Sefidvash at the Federal University of Rio Grande do Sul in Brazil. The FBNR constitutes a part of the IAEA Coordinated Research Project on Small Reactors without On-site Refuelling.

Small reactors without on-site refuelling are defined as reactors which have a capability to operate without refuelling and reshuffling of fuel for a reasonably long period consistent with the plant economics and energy security, with no fresh and spent fuel being stored at the site outside the reactor during its service life. They also should ensure difficult unauthorized access to fuel during the whole period of its presence at the site and during transportation, and design provisions to facilitate the implementation of safeguards. This definition does not include replacement of well-contained fuel cassette(s) in a manner that prohibits clandestine diversion of nuclear fuel material.

The work plan regarding the neutronics calculation study of the FBNR consists of:

- Using the HAMMER/WIMS codes for cell calculations, to prepare cross-section data for reactor calculations in different states of the FBNR;
- To study neutronics design of the FBNR, to perform design optimization of its long-life core, to determine

reactivity effects and coefficients for the core, and to perform preliminary analysis of the FBNR safety features.

2. Main features of the FBNR for neutronics calculation study

(1) Fuel element description

The 15-mm diameter spherical fuel elements are made of compacted-coated particles in a graphite matrix. For each fuel element, the fuel particles include 60% of the fuel element volume and the dense graphite matrix - 40%. The coated particles are similar to TRISO fuel with outer diameters about 2 mm. They consist of 1.58-mm diameter uranium dioxide spheres coated with 3 layers. The inner layer is of 0.09-mm thick porous pyrolytic carbide (PYC) with density of 1 g/cm³ called buffer layer, providing space for gaseous fission products. The second layer is of 0.02 mm-thick dense PYC (density of 1.8 g/cm³). And the outer layer is 0.1-mm thick corrosion resistant silicon carbide (SiC, density of 3.17 g/cm³). The fuel element is clad by 1 mm thick SiC. The tasks are to calculate neutronics physics for two cases of the fuel enrichments: U²³⁵ 5% and U²³⁵ 19%. Table 1 shows data on the fuel particle of 2-mm diameter and table 2 presents data on the fuel element of 15-mm diameter.

Table 1. Fuel particle

Material	Density (g/cm ³)	D. inside (cm)	D. outside (cm)	Volume (cm ³)	Mass (gr)
UO ₂	10.5	0	0.158	0.002065 237	0.021684 988
PYC (porous)	1	0.158	0.176	0.000789 306	0.000789 306
PYC (dense)	1.8	0.176	0.18	0.000199 085	0.000358 353
SiC	3.17	0.18	0.2	0.001135 162	0.003598 464

Table 2. Fuel element

Material	Mass (gr)	Volume (cm ³)	Density (g/cm ³)	Mass fraction	Volume fraction
UO ₂	3.578	0.341	10.5	0.501	0.193
PYC (porous)	0.130	0.130	1	0.0182	0.0737
PYC (dense)	0.887	0.493	1.8	0.124	0.279
SiC	2.549	0.804	3.17	0.357	0.455
Fuel element	7.145	1.768	4.041	1	1

(2) *Reactor core*

The Fixed Bed Nuclear Reactor (FBNR) is modular in design. Each module is to be fuelled in the factory and then the fuelled modules in sealed form are transported to and from the site.

The basic modules have in its upper part the reactor core and steam generator and in its lower part the reserve fuel chamber (see figure 1). The core consists of two concentric perforated zircaloy tubes of 20 cm and 160 cm in diameters, inside which, during the reactor operation, the spherical fuel elements are held together by the coolant flow in a fixed bed configuration, forming a suspended core (see figure 2, table 3 and table 4). In fact, insertion of the fresh fuel elements from the fuel chamber into the core via the reserve fuel chamber to make the reactor critical and simultaneously to timely compensate fuel burn-up in the core is carried out by water flow and the core level limiter. Therefore, in process of reactor operation the core height need be gradually changed from low to higher levels. In addition to that, it is possible to use a control rod in the core center to readjust any fine reactivity.

The reserve fuel chamber is a 40 cm diameter tube made of high neutron absorbing alloy, which is directly connected underneath the core tube. The fuel chamber consists of a helical 25 cm diameter tube connected to the reserve fuel chamber.

A signal from any detector due to initiating events is assumed to cut-off power from the pump, causing the fuel elements to leave the core and fall back into the fuel

chamber, where they remain in a highly subcritical and passively cooled condition.

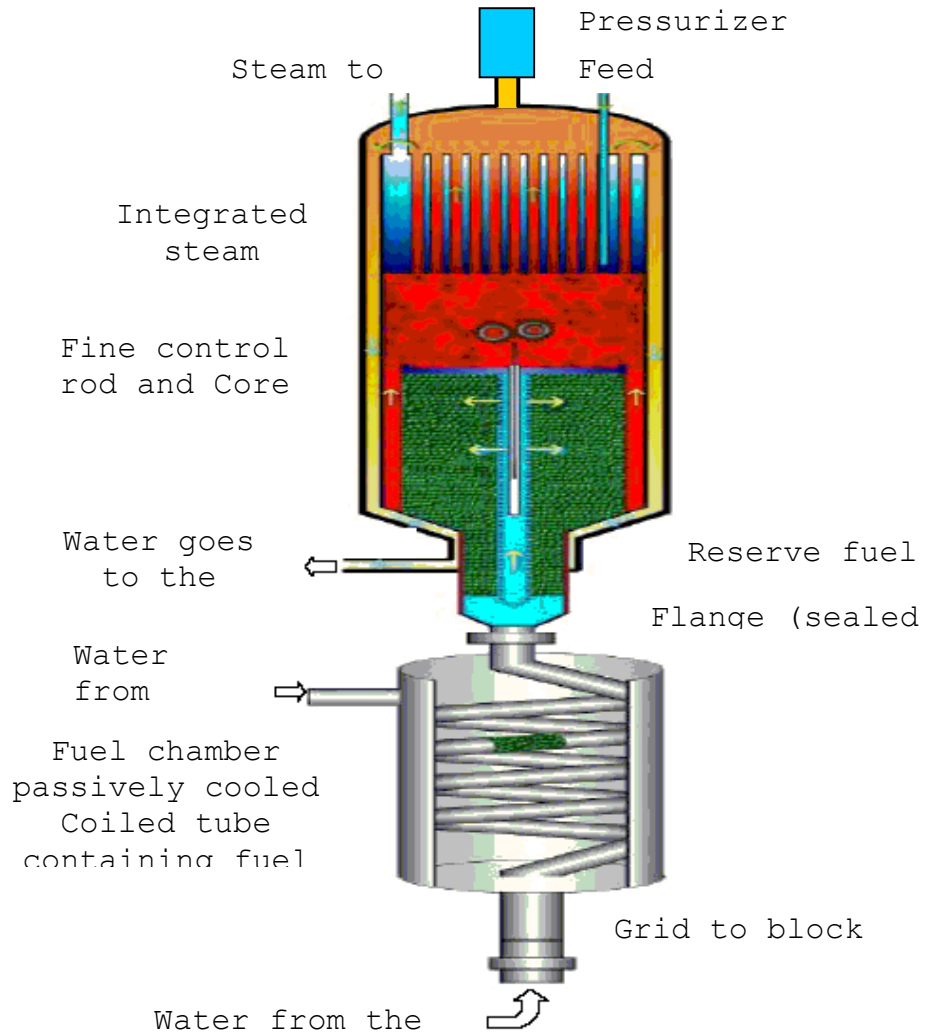

Figure 1. Schematic design of the FBNR

Table 3. Volume fraction (%) of the materials in a FBNR module

	UO ₂	H ₂ O	C	Stee	Zircal	SiC	Fuel	Total

				1	oy			
Region 1	0	95	0	0	5	0	0	100%
Region 2	11.58	40	21.1	0	0	27.3	60	100%
Region 3	0	95	0	5	1	0	0	100%

Remark:

- Stainless steel with a density of 7.758 g/cm³ is composed of 67.84% Fe, 10.86% Ni, 19.22 Cr, 1.88% Mn, and 0.20% Si.
- Zircaloy with a density of 5.874 g/cm³ is composed of 99.69% Zr, 0.21% Fe, and 0.10% Cr.
- Region 3 does not include pressure vessel.
- The reactor pressure vessel with a thickness of 8 cm is made of stainless steel.

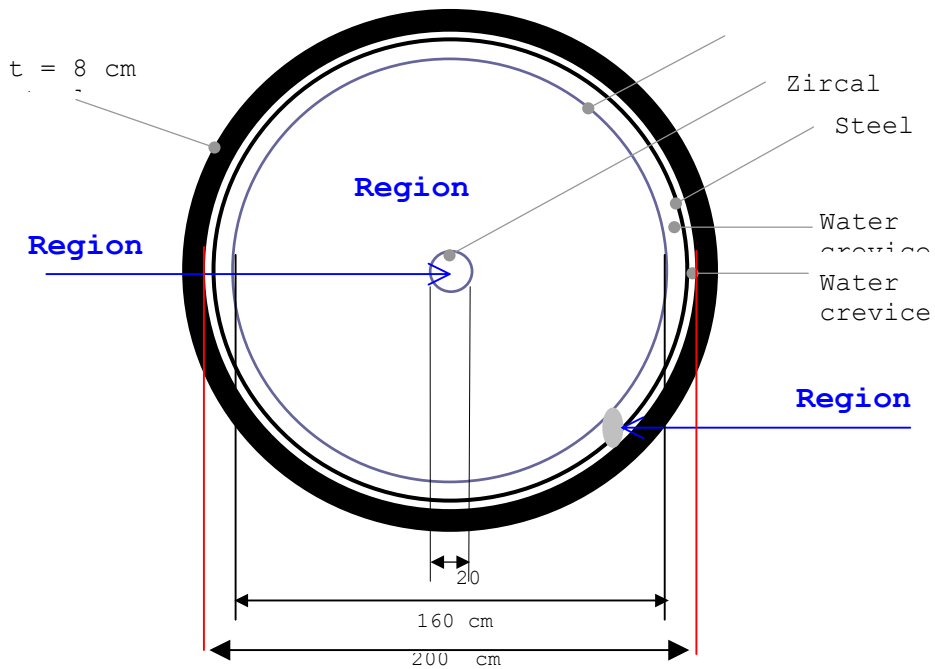

Figure 2. Reactor core

Table 4. Some characteristics related to neutronics physics

Parameter	Value
Power generation (MWth)	134
Net power generation (MWe)	40
Coolant pressure (bar)	160
Average coolant water temperature (°C)	308
Coolant inlet temperature (°C)	290
Coolant outlet temperature (°C)	326
Core height (cm)	200
Core inner diameter (cm)	20
Core outer diameter (cm)	160
Core volume (m ³)	3.96
Fuel in the core (Ton)	9.60
UO ₂ in the core (Ton)	4.81
Fuel element diameter (cm)	1.5
SiC clad thickness (cm)	0.1
UO ₂ density (g/cm ³)	10.5
PYC porous density (g/cm ³)	1.0
PYC dense density (g/cm ³)	1.8
SiC density (g/cm ³)	3.17

3. Neutronics calculations for the FBNR

3.1 Preparation of cross-section data for reactor calculations in different states of the FBNR by using the HAMMER/WIMS codes for cell calculations

From the design data in table 1 and table 2 and by using the HAMMER code for cell calculations, the effective cross-sections and infinite neutron multiplication coefficients (K_{inf}) for the FBNR fuel cells in two different fuel enrichment cases of 5% and 19% are determined (see table 5). And also, with the data from table 3 and table 4, the effective cross-sections for region 1, region 3, and water cells... are calculated (see table 6).

Table 5. Effective cross-sections and K_{inf} for the FBNR fuel cell (region 2)

Parameter	Fuel-UO ₂ enrichment	
	5%	19%
K_{inf}	1.332726	1.529120
Effective macroscopic absorption cross-section Σ_a , cm ⁻¹ :		
- For fast neutron group	6.43834 10 ⁻³	1.02109 10 ⁻²
- For thermal neutron group	2.42907 10 ⁻²	7.84468 10 ⁻²
Effective macroscopic fission cross section Σ_f , cm ⁻¹ :		
- For fast neutron group	1.61151 10 ⁻³	4.63934 10 ⁻³
- For thermal neutron group	1.70511 10 ⁻²	6.37289 10 ⁻²
Effective production cross-section $\nu\Sigma_f$, cm ⁻¹		
- For fast neutron group	3.97979 10 ⁻³	1.13448 10 ⁻²
- For thermal neutron group	4.12432 10 ⁻²	1.54147 10 ⁻¹

Effective cross-section for scatter $\Sigma_R, \text{ cm}^{-1}$:	1.25956 10^{-2}	9.79051 10^{-3}
- For fast neutron group	0.0	0.0
- For thermal neutron group		
Diffusion coefficient $D, \text{ cm}$:	1.34662	1.36604
- For fast neutron group	6.52303 10^{-1}	5.95766 10^{-1}
- For thermal neutron group		

Table 6. Effective cross-sections for other region of the FBNR

Cell	Group	Parameter		
		$\Sigma_a, \text{ cm}^{-1}$	$\Sigma_R, \text{ cm}^{-1}$	$D, \text{ cm}$
Region 1	Fast neutron	$4.24421 \cdot 10^{-4}$	$3.31128 \cdot 10^{-2}$	1.73481
	Thermal neutron	$1.30512 \cdot 10^{-2}$	0.0	$2.16298 \cdot 10^{-1}$
Region 3	Fast neutron	$6.37769 \cdot 10^{-4}$	$3.28343 \cdot 10^{-2}$	1.65159
	Thermal neutron	$2.30596 \cdot 10^{-2}$	0.0	$2.18597 \cdot 10^{-1}$
Water (at 308°C)	Fast neutron	$3.50242 \cdot 10^{-4}$	$3.46002 \cdot 10^{-2}$	1.75350
	Thermal neutron	$1.33662 \cdot 10^{-2}$	0.0	$2.07128 \cdot 10^{-1}$

In addition, the effective cross-sections and infinite multiplication coefficients for the FBNR fuel cell are calculated in cases of the fuel enrichments of 2, 3, 4, and 6% (see table 7); and then change of cross-sections and K_{inf} in function of the FBNR operation time are also determined for the fuel enrichments of 5% and 19%. The fuel enrichment of 19% is considered, because it stays below the 20% nuclear material limit allowed. All the reactor cell parameters mentioned above are used to simulate the FBNR for its neutronics physics study.

Table 7. Effective cross-sections of the FBNR fuel cell for different enrichments.

Fuel Enrich. h.	Neutron group	Parameter				
		$\Sigma_f, \text{ cm}^{-1}$	$\nu\Sigma_{f,1}, \text{ cm}^{-1}$	$\Sigma_a, \text{ cm}^{-1}$	$\Sigma_R, \text{ cm}^{-1}$	$D, \text{ cm}$

2 %	Fast	8.27367 10^{-4}	2.07448 10^{-3}	5.42944 10^{-3}	1.33668 10^{-2}	1.34220
	Thermal	6.96424 10^{-3}	1.68451 10^{-2}	1.26183 10^{-2}	0.0	6.63922 10^{-1}
3 %	Fast	1.09520 10^{-3}	2.72515 10^{-3}	5.77492 10^{-3}	1.31015 10^{-2}	1.34376
	Thermal	1.03361 10^{-2}	2.50009 10^{-2}	1.65135 10^{-2}	0.0	6.60429 10^{-1}
4%	Fast	1.35612 10^{-3}	3.35913 10^{-3}	6.11008 10^{-3}	1.28451 10^{-2}	1.34525
	Thermal	1.36921 10^{-2}	3.31186 10^{-2}	2.03978 10^{-2}	0.0	6.56484 10^{-1}
6%	Fast	1.85878 10^{-3}	4.58070 10^{-3}	6.75201 10^{-3}	1.23566 10^{-2}	1.34825
	Thermal	2.03832 10^{-2}	4.93030 10^{-2}	2.81517 10^{-2}	0.0	6.48148 10^{-1}

3.2 Influence of the fuel enrichment and core height on infinite and effective neutron multiplication coefficients of the FBNR.

When the fuel enrichment is changed, it means that the fuel cell parameters are also changed, and then the infinite and effective neutron multiplication coefficients (Kinf and Keff) are affected. Kinf and Keff are calculated by using the CITATION code for fuel enrichments of 2, 3, 4, 5, 6% in condition of the reactor operating at a power of 134 MWth and a core height of 200 cm (see table 8 and figure 4). Here, the core height is defined to be a distance from the cylinder's bottom to its top.

Table 8. Kinf and Keff in function of fuel enrichment

	Fuel enrichment, %	Kinf	Keff
1	2	1.059767	0.929432
2	3	1.195214	1.062907

3	4	1.277536	1.146225
4	5	1.332726	1.203161
5	6	1.372283	1.244472

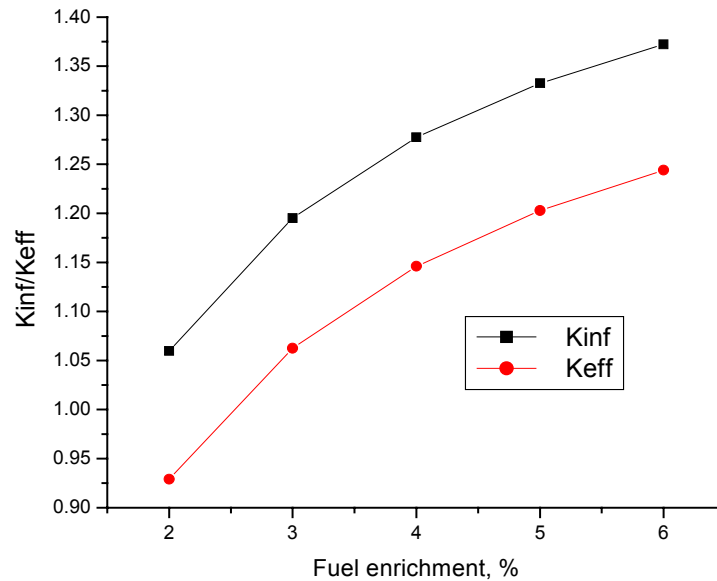

Figure 4: Infinite and effective neutron multiplication

It is assumed that at the FBNR's fuel enrichment of 5%, with different core heights, the effective neutron multiplication coefficient, K_{eff} , according to calculation, has to be changed in function of core height. This change is presented in table 9 and figure 5.

Table 9. K_{eff} in function of the core height.

	Core height, cm	K_{eff}
1	18.64	1.000017
2	30	1.052515

3	50	1.110316
4	75	1.149487
5	100	1.171248
6	150	1.193051
7	200	1.203161
8	250	1.208608

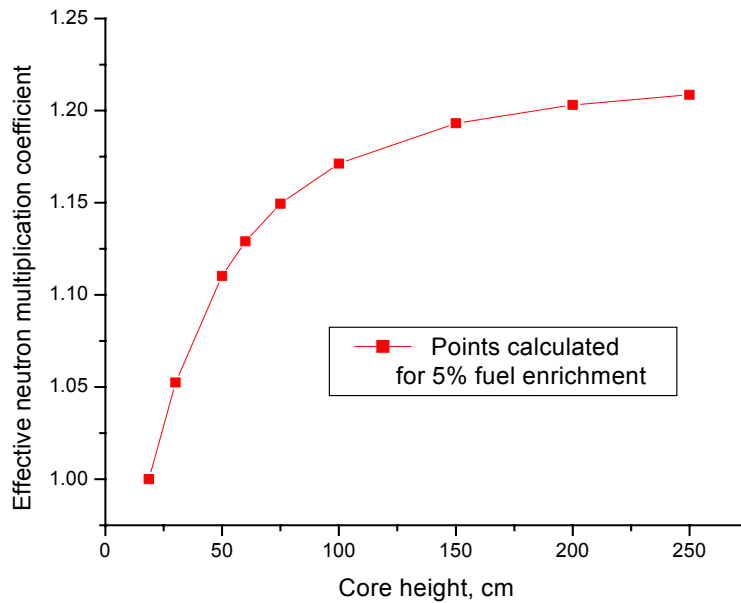

Figure 5: Effective neutron multiplication coefficient in

From the results mentioned above, it sees that:

- To make the reactor critical its core height is to be 18.64 cm for the 5% fuel enrichment;
- With the increase in core height to 200 cm the reactor excess reactivity does not increase significantly for the 5% fuel enrichment, but its core lifetime in case of specific operation may be longer than in case of usual operation because of a good neutron economy for no burnable poison. This is investigated later in section 3.3.

3.3 Change of the effective neutron multiplication coefficient in accordance with reactor operation time.

The reactor that has the core height of 200 cm is assumed to operate at a power of 134 MWth in case of fuel

enrichments 5% and 19%. Changes of the fuel cell parameters during the reactor operation time, it means that, in the process of fuel burn-up are calculated, and then changes of the effective neutron multiplication coefficients for fuel enrichments of 5% and 19% are also determined (see figure 6). Table 10 shows main interested values of the effective neutron multiplication coefficients in the process of fuel burn-up.

Table 10. K_{inf}/K_{eff} for the height of 200 cm and 5% & 19% enrichments

Operati on time, days	5% enrichment		19% enrichment	
	K_{inf}	K_{eff}	K_{inf}	K_{eff}
0	1.332726	1.203161	1.529120	1.414162
1091	1.104883	0.999976		
6286			1.103285	1.000014

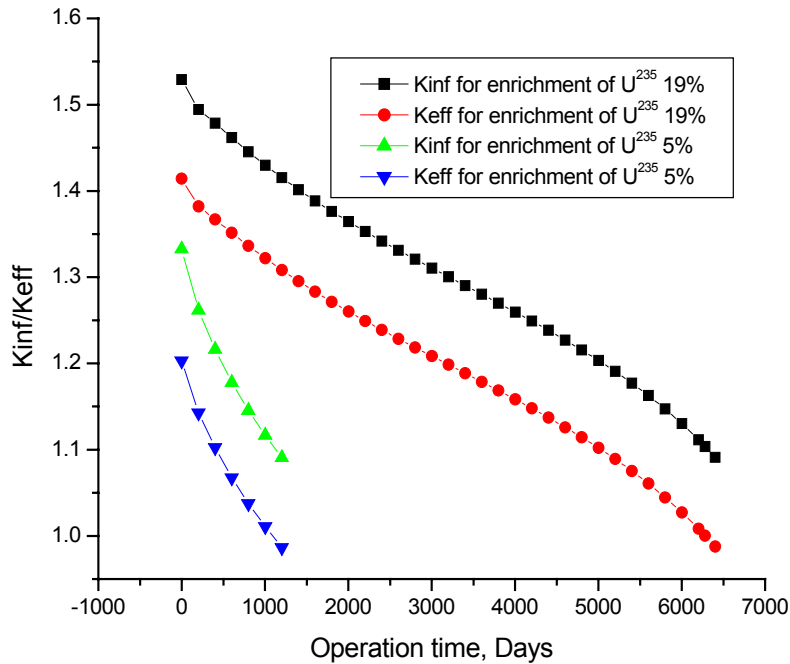

Figure 6. K_{inf} and K_{eff} in function of the FBNR's operation

From the results above it is seen that to get more than 10 years core lifetime the 19% fuel enrichment is suggested;

and if the 5% fuel enrichment is chosen the core lifetime reaches only about 3 years.

According to **usual operation** (it defined that all the fuel elements in the core of the 200 cm height are simultaneously used in process of reactor operation, and during that operation time the reactor is maintained in critical states by using control rods), for the two fuel enrichments there are choices as follows:

- The reactor has about 3 years core lifetime with the characteristics of:
 - (1) Low enrichment of 5%
 - (2) Less fuel cost, but more operational cost (number of changes for the sealed fuel chamber).
- The reactor has more than 10 years fuel lifetime with the characteristics of:
 - (1) High but legal enrichment of 19%,
 - (2) More fuel cost, but less operational cost.

In case of **specific operation** for the FBNR, according to Prof. Dr. Farhang Sefidvash's promotion, the reactor is first made to be critical by insertion of a quantity of fresh fuel elements into the reactor core and simultaneously the control rod at the core center may be used for this criticality. After that, the insertion of fresh fuel elements from the fuel chamber into the core is performed continuously to compensate for fuel burn-up so that the reactor may operate in critical states. Therefore, in the reactor there is no burnable poison with very good neutron economy. By using such procedure of reactor operation, the core lifetime is much more extended.

To make an illustrative example for the reactor specific operation mentioned above, it is assumed to carry out a procedure for reactor operation as follows: in fact the such fresh fuel elements will continuously compensate for fuel burn-up in the reactor by adjusting the core level limiter, but in calculation it can not continuously raise such core levels because it takes very much calculation time; therefore only 4 different core levels with heights of 60 cm, 100 cm, 140 cm, and 200 cm for 5% fuel enrichment are considered, concretely:

- (1) Calculations for a core height of 60 cm are carried out to find changes of K_{inf} and K_{eff} in function of reactor operation time.
- (2) When $K_{eff} = 1$, the core level limiter is raised to a height of 100 cm and fresh fuel elements from the fuel chamber enter the core. It is assumed that the fresh and

old fuel elements in the reactor core are turned up with together. Calculations of the K_{inf} and K_{eff} changes in function of operation time are repeated.

- (3) When $K_{eff} = 1$, the core level limiter is again raised to 140 cm and allow fresh fuel elements from the fuel chamber to enter the core. The fresh fuel elements and the old fuel elements in the core are mixed with together again. Then the K_{inf} and K_{eff} changes in function of operation time are calculated.
- (4) In the last case when $K_{eff} = 1$, the core level limiter is raised to 200 cm and every thing is carried out as one mentioned above. The calculated results are presented in tables 11, 12, 13 and 14, and figure 7.

As mentioned above, according to *usual operation* the core lifetime calculated for the 5% fuel enrichment is equal to 1091 operation days (about 3 years; $K_{eff} = 1.203161$ by 0 day and $K_{eff} = 0.999976$ for 1091 days); but in accordance with the *specific operation* procedure for the FBNR, the core lifetime is 1927 operation days (5.3 years). Therefore, if the fresh fuel elements more continuously (systematically) enter in the core to compensate for fuel burn-up, the core lifetime is definitely much longer than 1927 days.

Table 11. Results for the core height of 60 cm

Operation time, days	K_{inf}	K_{eff}
0	1.332726	1.129087
202	1.261879	1.074496
402	1.216257	1.036919
602	1.177757	1.004124
622	1.174269	1.001113
630	1.172950	0.999969

Table 12. Results for the core height of 100 cm

Operation time, days	K_{inf}	K_{eff}
630	1.299345	1.075814
692	1.200484	1.059525
792	1.184174	1.045239
892	1.16973	1.030860
992	1.152297	1.016798
1116	1.133842	1.000078

Table 13. Results for the core height of 140 cm

Operation time, days	Kinf	Keff
1116	1.177586	1.054592
1198	1.159449	1.038436
1298	1.145203	1.025508
1400	1.130554	1.012094
1493	1.117404	0.999961

Table 14. Results for the core height of 200 cm

Operation time, days	Kinf	Keff
1493	1.176019	1.063806
1595	1.154102	1.044131
1695	1.139842	1.031096
1795	1.125270	1.017663
1895	1.110813	1.004239
1927	1.106292	1.000027

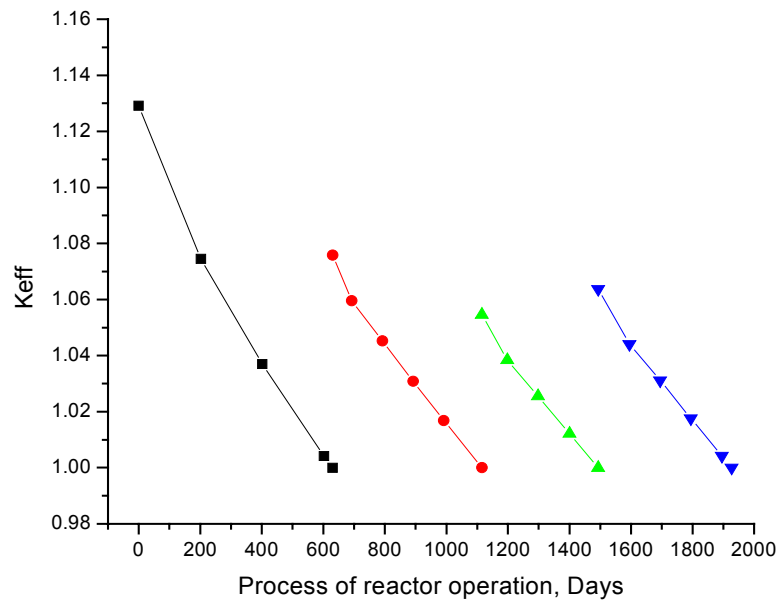

Figure 7. Process of reactor operation with 4 times of inserting fuel elements into the

3.4 Temperature coefficient of the reactor reactivity

The temperature coefficient of the reactor reactivity is determined as follows:

(1) For 5% fuel enrichment

- Kinf and Keff for the FBNR's configuration with the core height of 200 cm, the fuel enrichment 5%, and different fuel and water temperatures (the fuel temperature is assumed to be changed as water one) are calculated at the moment when the reactor starts its operation (see table 15).
- Temperature coefficient of the reactor reactivity in this case are determined according to the formulas:

$$\rho_t = \rho_{(2)}(t_2) - \rho_{(1)}(t_1) = \frac{K_{eff2} - K_{eff1}}{K_{eff1} K_{eff2}}$$

$$\alpha_t = \frac{\Delta \rho_t}{\Delta t},$$

Where, t is water temperature, α_t is its temperature coefficient of reactor reactivity.

Table 15. Kinf/Keff at different water temperatures

	Water temperature, °C	Water density, g/cm ³	Kinf	Keff
1	290	0.74761	1.337521	1.211824
2	300	0.72801	1.335019	1.207294
3	310	0.70636	1.332128	1.202091
4	320	0.68199	1.328684	1.195957
5	330	0.65372	1.324408	1.188454

The average temperature coefficient of the reactor reactivity, in case of 5% fuel enrichment, determined during the fuel and water temperature interval from 290°C to 330°C is:

$$\bar{\alpha} = -4.056710^{-4} / ^\circ C \quad \text{or}$$

$$\bar{\alpha} = -40.567 \text{ pcm}/^\circ C$$

(2) For 19% fuel enrichment

Similarly, the temperature coefficient of the reactor reactivity in case of 19% fuel enrichment is:

$$\bar{\alpha} = -3.860110^{-4} / ^\circ C \quad \text{or}$$

$$\bar{\alpha} = -38.601 \text{ pcm}/^\circ C$$

3.5 Neutron flux distributions

The results on the fast and thermal neutron fluxes in the FBNR's radial and axial directions, calculated by 1091st day and 6286th day since their starting of usual operation process for the 5% and 19% fuel enrichments respectively, are shown in figures 8, 9, and 10.

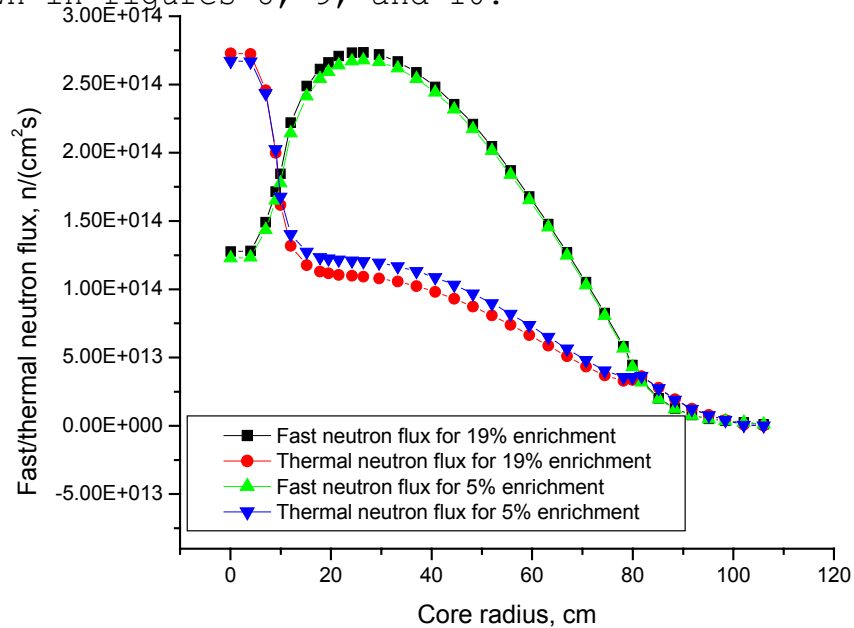

Figure 8. Fast and thermal neutron flux distributions in the FBNR's radial

According to calculations, it sees that:

- The fast neutron fluxes for the 5% and 19% fuel enrichments reach the maximum values of $\approx 2.67710^{14}$ n/(cm²s) and $\approx 2.73410^{14}$ n/(cm²s) respectively at the

radius of about 26.447 cm from the reactor center and at the depth of 114 cm from the core top;

- The thermal neutron fluxes for the 5% and 19% fuel enrichments have the maximum values of $\approx 2.67210^{14}$ n/(cm²s) and $\approx 2.72810^{14}$ n/(cm²s) respectively at the reactor center and at the depth of 114 cm from the core top, on the contrary, where the fast neutron fluxes reach the values of 1.22810^{14} n/(cm²s) and 1.27610^{14} n/(cm²s) for the respective fuel enrichments.
- The average neutron fluxes by region and group are presented in table 16.

Table 16. Average fast and thermal neutron fluxes by region and group

Region	5% fuel enrichment		19% fuel enrichment	
	Fast neutron flux, n/(cm ² s)	Thermal neutron flux, n/(cm ² s)	Fast neutron flux, n/(cm ² s)	Thermal neutron flux, n/(cm ² s)
Region 1	$8.029 \cdot 10^{13}$	$1.311 \cdot 10^{14}$	$8.357 \cdot 10^{13}$	$1.322 \cdot 10^{14}$
Region 2 (Fuel)	$1.194 \cdot 10^{14}$	$5.534 \cdot 10^{13}$	$1.219 \cdot 10^{14}$	$5.025 \cdot 10^{13}$
Reserve fuel region	$1.375 \cdot 10^{12}$	$8.218 \cdot 10^{11}$	$1.482 \cdot 10^{12}$	$8.052 \cdot 10^{11}$

The data from table 16 shows that the fuel elements from the reserve fuel chamber that is made of a high neutron absorber do not considerably contribute to the core reactivity because the neutron fluxes in these regions are much smaller than in the reactor core.

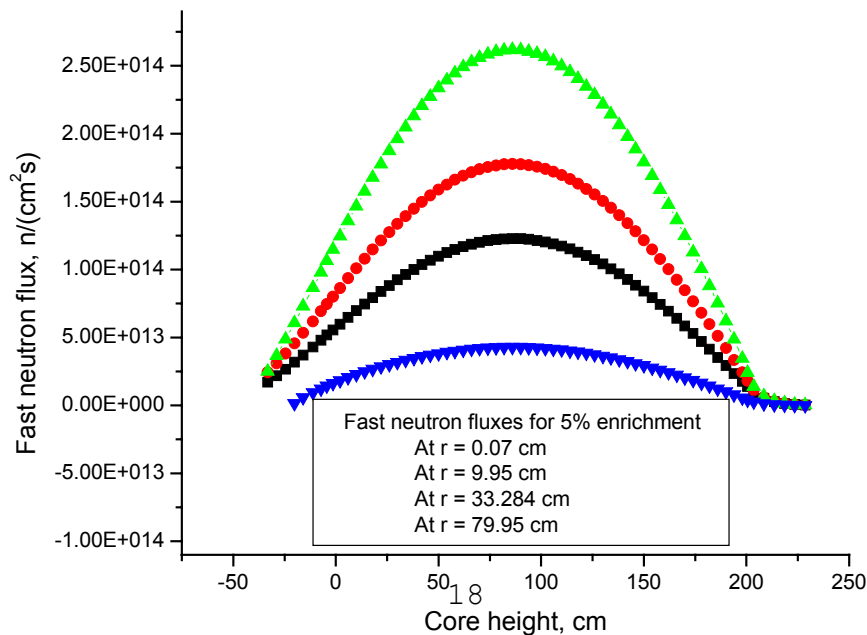

Figure 9. Fast neutron flux distributions in the FBNR's radial direction

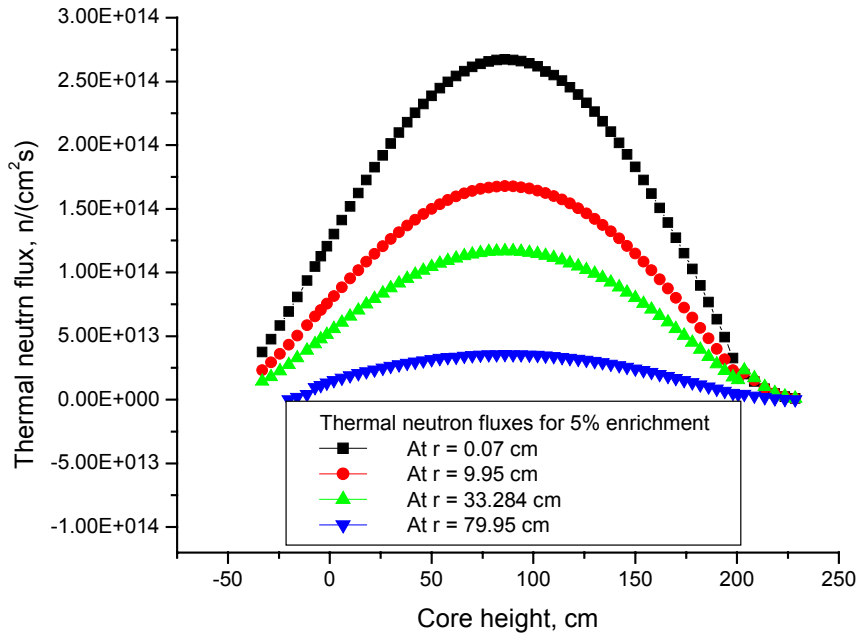

Figure 10. Fast neutron flux distributions in the FBNR's radial direction

The neutron flux distributions at the 5% fuel enrichment result in that the FBNR heterogeneous coefficients of energy generation (peaking factors) are as follows:

- The axial heterogeneous coefficients of energy generation, k_z , calculated at a radius of 26.447 cm have values as follows:
 - $k_z = 1.57$ for the fast neutron group; and
 - $k_z = 1.55$ for the thermal neutron group.
- The radial heterogeneous coefficients of energy generation, k_r , calculated at a depth of 114 cm from the core top have values:
 - $k_r = 1.08$ for the fast neutron group; and
 - $k_r = 1.50$ for the thermal neutron group.

The calculations for the 5% fuel enrichment also show that the specific heat generation from the hottest fuel elements located at the 26.447 cm radius and the 144 cm depth in the reactor core is equal to 66.58 W/cm^3 .

4. Reactor control rod

As mentioned above, for the FBNR the long-term reactivity is supplied by fresh fuel addition into the core from the fuel chamber and a fine control rod that moves along the reactor core axis controls the short-term reactivity. It is assumed that the fine control rod with a diameter of 2 mm is made of the materials like those used for Pressurized Water Reactors (PWRs), including 80^{w/o} Silver, 15^{w/o} Indium, 5^{w/o} Cadmium, and 0.5 mm thickness of stainless steel cladding. The fine control rod, according to calculations, has a total reactivity of 63.7 pcm and its integral characteristic is shown in figure 11.

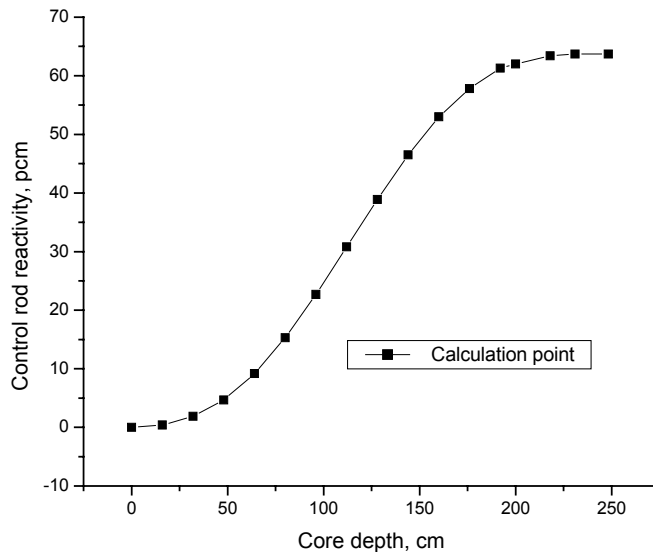

Figure 11. Integral characteristic of the fine control rod

5. Conclusions

This is a report aimed at summing up all the contents carried out under the IAEA Research Contract No. 12965/R1-RBF on neutronics physics study for the Fixed Bed Nuclear Reactor (FBNR), which constitutes a part of the IAEA Coordinated Research Project on Small Reactors without On-site Refuelling. Based on the results obtained from neutronics calculations of the FBNR such as the changes of

Kinf/Keff coefficients in function of fuel enrichments, core height, and operation time; temperature coefficient of the reactor reactivity; and the fast and thermal flux distributions..., some main conclusions are drawn as follows:

- By continuously insertion of fresh fuel elements from the fuel chamber into the reactor core to compensate for fuel burn-up, the core lifetime is extended much more;
- With such a reactor operation measure, in plus of every probable accident causing the cut-off of the power to the pump, which leads into fall of all the fuel elements out of the core by the force of gravity into the fuel chamber, so a positive reactivity accident for the FBNR can not happens;
- As known, for water-water reactors temperature coefficients of reactivity usually includes $-(1 \div 4) \times 10^{-4}/^{\circ}\text{C}$ while the temperature coefficient of the Fixed Bed Nuclear Reactor is $-4.06 \times 10^{-4}/^{\circ}\text{C}$ in case of the 5% fuel enrichment and $-3.86 \times 10^{-4}/^{\circ}\text{C}$ in case of the 19% fuel enrichment, so the FBNR has a high inherent safety;
- The FBNR has high thermal flux values (2.67210^{14} n/(cm²s) and 2.72810^{14} n/(cm²s) for the 5% and 19% fuel enrichment respectively) at the core center. Therefore, the control rods made of materials similar to the PWR control rods may be used to adjust the FBNR reactivity; and
- The heterogeneous coefficients of the reactor energy generation and the maximum specific heat generation of the FBNR only reaches 66.58 W/cm^3 are not so big in compare with other reactors adjusted by control rod systems. Therefore, reliance on safety of temperature and energy generation distributions in the reactor core is assured.

6. Acknowledge

Authors would like to express a deep gratitude to Dr. V. V. Kuznetsov - scientific secretary of the IAEA CRP, and IAEA administration section for their useful supports to develop this study. Authors especially wish to thank Prof. Dr. Farhang Sefidvash from Brazil who read and give value comments for the results presented in this report.

Reference

1. Farhang Sefidvash. *Fixed Bed Nuclear Reactor Concept*. Nuclear Engineering Department, Federal University of Rio Grande do Sul, Porto Alegre, Brazil.

2. Fahang Sefidvash. *Conceptual design of the Fixed Bed Nuclear Reactor (FBNR) Concept*. IAEA Year 2005 Report - IAEA Research Contract No. 12960/RBF
3. J. Barhen, W. Rothenstein, and E. Taviv. *Heterogeneous Analysis by Multigroup Methods of Exponentials and Reactors-HAMMER code*. Department of Nuclear Engineering/Institute of Technology Haifa, New York (1994).